

# MODEL 253

## Reverse Phase Relay

- Socket-mounted
- Senses phase reversal
- Low power consumption
- UL Recognized; CSA Certified



### DESCRIPTION

The **Model 253 Reverse Phase Relay** is a solid-state sensing device designed for installation in equipment using 3-phase power. This unit is used where it is desirable to have a contact closure indicating that the proper phase rotation sequence has been applied.

The relay closes when the proper sequence (**A B C**) is applied, but will remain open if any two phases are reversed. If reverse phasing occurs during operation, the relay also de-energizes.

The Model 253 has a special industrial grade relay designed for low power consumption. The **A B C** indicator will be illuminated when the proper phase rotation sequence is applied.

### SPECIFICATIONS

Model	253
Nominal voltage	208 - 480 VAC (phase to phase)
Operating range	190 - 480 VAC
Frequency	50 to 60 Hz
Power consumption	2W per phase
Transient protection	2500V for 10 msec
Repeat accuracy	± 0.1% (fixed conditions)
Response time	.05 seconds
Reset time	.05 seconds
Reset type	Automatic
Dead Band	Approximately 2%
Output contacts	SPDT 10A at 240 VAC resistive
Expected relay life	Mechanical: 10 million operations Electrical: 100,000 at rated load
Operating temperature	- 40° to +131° F
Humidity tolerance	0 - 97% w/o condensation
Case material	ABS plastic
Mounting	8-pin socket *(order separately)
Weight	6 oz.
Agency approval	UL Recognized and CSA Certified

\* Order 8-pin socket number 51X120

### DIMENSIONS

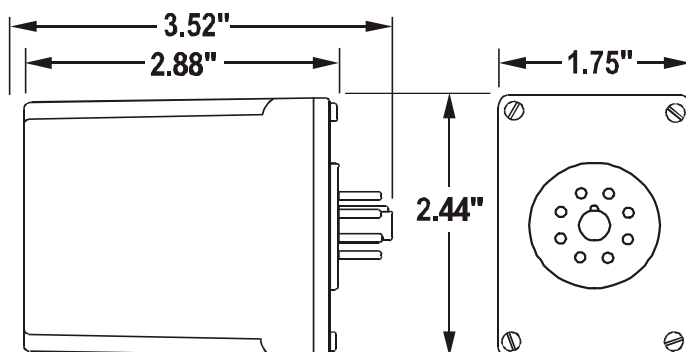

(dimensions have tolerance of ± 0.06)



**TIME MARK**  
CORPORATION