

Battery and Connector Contacts

101190 PROBE

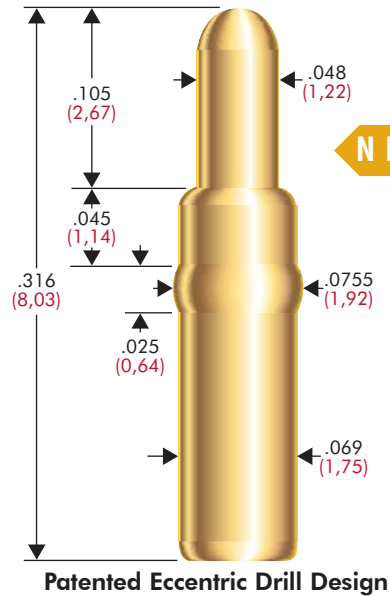

101066 PROBE

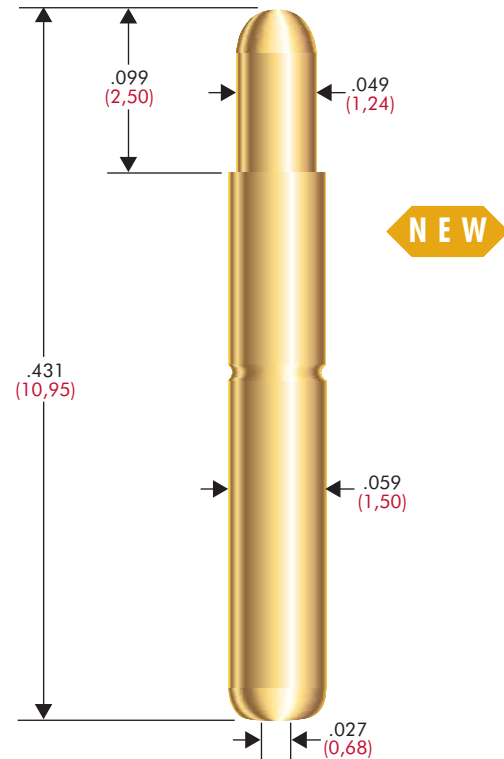

PROBE SPECIFICATIONS

Minimum Centers: .100 (2,54)
Current Rating: 15 amps continuous
 (Single probe horizontal in air; Temp Rise = 80° C)
Spring Force: 2.6 oz (74g) @ .067 (1,70) travel
Typical Resistance: <6 mΩ
Maximum Travel: .100 (2,54)
Working Travel: .067 (1,70)

MATERIALS

Barrel: Nickel/silver, gold plated
Spring: Stainless steel
Plungers: Full-hard beryllium copper, gold plated
Special Features: Press ring, patented eccentric drill design*

HOW TO ORDER

101190-002

PROBE SPECIFICATIONS

Minimum Centers: .075 (1,91)
Current Rating: 10 amps continuous
 (Single probe horizontal in air; Temp Rise = 80° C)
Spring Force: 1.2 oz. (34g) @ .073 (1,85) travel
Typical Resistance: <20 mΩ
Maximum Travel: .089 (2,26)
Working Travel: .073 (1,85)

MATERIALS

Barrel: Nickel/silver, gold plated
Spring: Stainless steel, gold plated
Plunger: Full-hard beryllium copper, gold plated
Special Features: Bias spring design

HOW TO ORDER

101066-000

* For more information on eccentric drill, see page 68
 For fixturing information on battery and connector contacts, see pages 122-123 of the Source Book.
 Specifications subject to change. Dimensions in inches (millimeters)