

"Half-Bridge" IGBT MTP (Warp Speed IGBT), 114 A

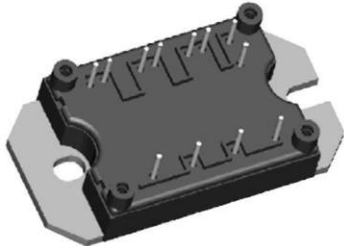

MTP

FEATURES

- Generation 4 warp speed IGBT technology
- HEXFRED® antiparallel diodes with ultrasoft reverse recovery
- Very low conduction and switching losses
- Optional SMD thermistor (NTC)
- Very low junction to case thermal resistance
- ULE78996 approved
- Speed 60 to 100 kHz
- Totally lead (Pb)-free
- Designed and qualified for industrial level

**RoHS
COMPLIANT**

PRODUCT SUMMARY

V_{CES}	600 V
$V_{CE(on)}$ typical at $V_{GE} = 15$ V	2.3 V
I_C at $T_C = 25$ °C	114 A

BENEFITS

- Optimized for welding, UPS and SMPS applications
- Low EMI, requires less snubbing
- Direct mounting to heatsink
- PCB solderable terminals
- Very low stray inductance design for high speed operation

ABSOLUTE MAXIMUM RATINGS

PARAMETER	SYMBOL	TEST CONDITIONS	MAX.	UNITS
Collector to emitter voltage	V_{CES}		600	V
Continuous collector current	I_C	$T_C = 25$ °C	114	A
		$T_C = 109$ °C	50	
Pulsed collector current	I_{CM}		350	
Peak switching current	I_{LM}		350	
Diode continuous forward current	I_F	$T_C = 109$ °C	34	
Peak diode forward current	I_{FM}		200	
Gate to emitter voltage	V_{GE}		± 20	V
RMS isolation voltage	V_{ISOL}	Any terminal to case, $t = 1$ minute	2500	
Maximum power dissipation	P_D	$T_C = 25$ °C	658	W
		$T_C = 100$ °C	263	

ELECTRICAL SPECIFICATIONS ($T_J = 25\text{ }^\circ\text{C}$ unless otherwise specified)						
PARAMETER	SYMBOL	TEST CONDITIONS	MIN.	TYP.	MAX.	UNITS
Collector to emitter breakdown voltage	$V_{(BR)CES}$	$V_{GE} = 0\text{ V}$, $I_C = 500\text{ }\mu\text{A}$	600	-	-	V
Collector to emitter voltage	$V_{CE(on)}$	$V_{GE} = 15\text{ V}$, $I_C = 50\text{ A}$	-	2.3	3.15	V
		$V_{GE} = 15\text{ V}$, $I_C = 100\text{ A}$	-	2.5	3.2	
		$V_{GE} = 15\text{ V}$, $I_C = 50\text{ A}$, $T_J = 150\text{ }^\circ\text{C}$	-	1.72	2.17	
Gate threshold voltage	$V_{GE(th)}$	$I_C = 0.5\text{ mA}$	3	-	6	
Collector to emitter leaking current	I_{CES}	$V_{GE} = 0\text{ V}$, $I_C = 600\text{ A}$	-	-	0.4	mA
		$V_{GE} = 0\text{ V}$, $I_C = 600\text{ A}$, $T_J = 150\text{ }^\circ\text{C}$	-	-	10	
Diode forward voltage drop	V_{FM}	$I_F = 50\text{ A}$, $V_{GE} = 0\text{ V}$	-	1.58	1.80	V
		$I_F = 50\text{ A}$, $V_{GE} = 0\text{ V}$, $T_J = 150\text{ }^\circ\text{C}$	-	1.49	1.68	
		$I_F = 100\text{ A}$, $V_{GE} = 0\text{ V}$, $T_J = 25\text{ }^\circ\text{C}$	-	1.9	2.17	
Gate to emitter leakage current	I_{GES}	$V_{GE} = \pm 20\text{ V}$	-	-	± 250	nA

SWITCHING CHARACTERISTICS ($T_J = 25\text{ }^\circ\text{C}$ unless otherwise specified)						
PARAMETER	SYMBOL	TEST CONDITIONS	MIN.	TYP.	MAX.	UNITS
Total gate charge (turn-on)	Q_g	$I_C = 52\text{ A}$ $V_{CC} = 400\text{ V}$ $V_{GE} = 15\text{ V}$	-	331	385	nC
Gate to emitter charge (turn-on)	Q_{ge}		-	44	52	
Gate to collector charge (turn-on)	Q_{gc}		-	133	176	
Turn-on switching loss	E_{on}	Internal gate resistors (see electrical diagram) $I_C = 50\text{ A}$, $V_{CC} = 480\text{ V}$, $V_{GE} = 15\text{ V}$, $L = 200\text{ }\mu\text{H}$ Energy losses include tail and diode reverse recovery, $T_J = 25\text{ }^\circ\text{C}$	-	0.26	-	mJ
Turn-off switching loss	E_{off}		-	1.2	-	
Total switching loss	E_{ts}		-	1.46	-	
Turn-on switching loss	E_{on}	Internal gate resistors (see electrical diagram) $I_C = 50\text{ A}$, $V_{CC} = 480\text{ V}$, $V_{GE} = 15\text{ V}$, $L = 200\text{ }\mu\text{H}$ Energy losses include tail and diode reverse recovery, $T_J = 150\text{ }^\circ\text{C}$	-	0.73	-	mJ
Turn-off switching loss	E_{off}		-	1.66	-	
Total switching loss	E_{ts}		-	2.39	-	
Input capacitance	C_{ies}	$V_{GE} = 0\text{ V}$ $V_{CC} = 30\text{ V}$ $f = 1.0\text{ mHz}$	-	7100	-	pF
Output capacitance	C_{oes}		-	510	-	
Reverse transfer capacitance	C_{res}		-	140	-	
Diode reverse recovery time	t_{rr}	$V_{CC} = 200\text{ V}$, $I_C = 50\text{ A}$ $di/dt = 200\text{ A}/\mu\text{s}$	-	82	97	ns
Diode peak reverse current	I_{rr}		-	8.3	10.6	A
Diode recovery charge	Q_{rr}		-	340	514	nC
Diode reverse recovery time	t_{rr}	$V_{CC} = 200\text{ V}$, $I_C = 50\text{ A}$ $di/dt = 200\text{ A}/\mu\text{s}$ $T_J = 125\text{ }^\circ\text{C}$	-	137	153	ns
Diode peak reverse current	I_{rr}		-	12.7	14.8	A
Diode recovery charge	Q_{rr}		-	870	1132	nC

THERMISTOR SPECIFICATIONS						
PARAMETER	SYMBOL	TEST CONDITIONS	MIN.	TYP.	MAX.	UNITS
Resistance	$R_0^{(1)}$	$T_0 = 25\text{ }^\circ\text{C}$	-	30	-	k Ω
Sensitivity index of the thermistor material	$\beta^{(1)(2)}$	$T_0 = 25\text{ }^\circ\text{C}$ $T_1 = 85\text{ }^\circ\text{C}$	-	4000	-	K

Notes

 (1) T_0, T_1 are thermistor's temperatures

(2) $\frac{R_0}{R_1} = \exp\left[\beta\left(\frac{1}{T_0} - \frac{1}{T_1}\right)\right]$, temperature in Kelvin

THERMAL AND MECHANICAL SPECIFICATIONS							
PARAMETER	SYMBOL	TEST CONDITIONS	MIN.	TYP.	MAX.	UNITS	
Operating junction temperature range	IGBT, Diode		- 40	-	150	$^\circ\text{C}$	
	Thermistor		- 40	-	125		
Storage temperature range	T_{Stg}		- 40	-	125		
Junction to case	IGBT		-	-	0.38	$^\circ\text{C/W}$	
	Diode		-	-	0.8		
Case to sink	Module	R_{thCS}	Heatsink compound thermal conductivity = 1 W/mK		-	0.06	-
Clearance ⁽¹⁾			External shortest distance in air between two terminals		5.5	-	-
Creepage ⁽¹⁾			Shortest distance along the external surface of the insulating material between 2 terminals		8	-	-
Mounting torque to heatsink			A mounting compound is recommended and the torque should be checked after 3 hours to allow for the spread of the compound. Lubricated threads.		3 \pm 10 %		Nm
Weight					66		g

Notes

(1) Standard version only i.e. without optional thermistor

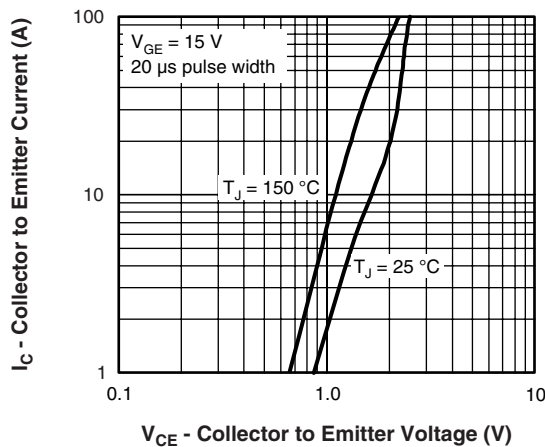

Fig. 1 - Typical Output Characteristics

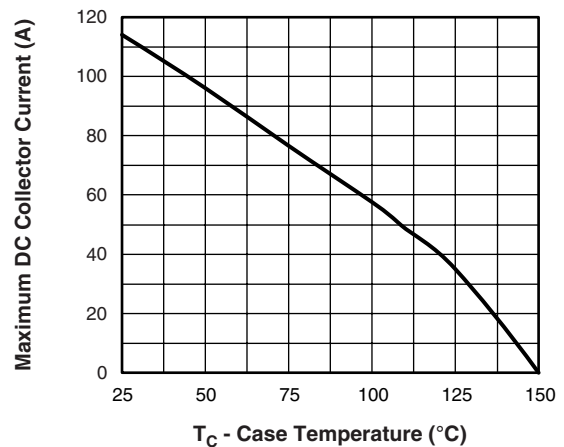

Fig. 2 - Maximum Collector Current vs. Case Temperature

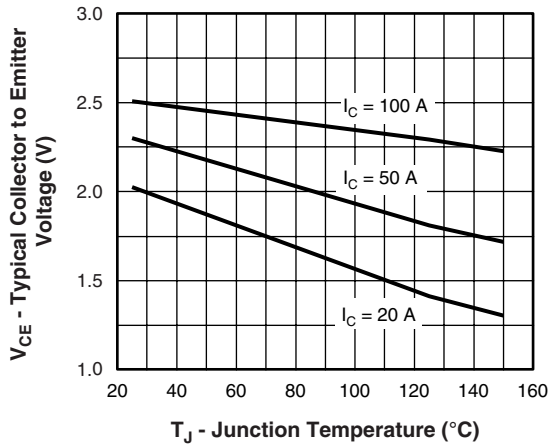

Fig. 3 - Typical Collector to Emitter Voltage vs. Junction Temperature

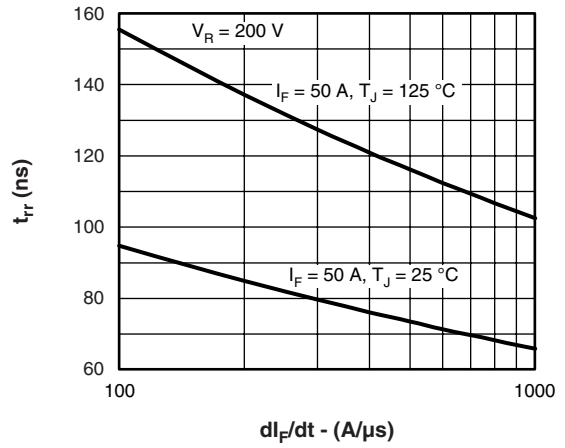

Fig. 6 - Typical Reverse Recovery Time vs. di_F/dt

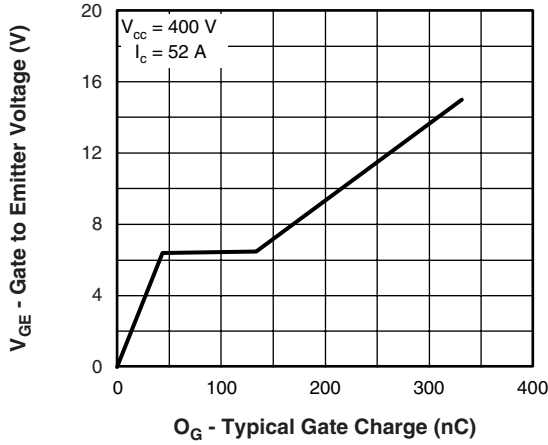

Fig. 4 - Typical Gate Charge vs. Gate to Emitter Voltage

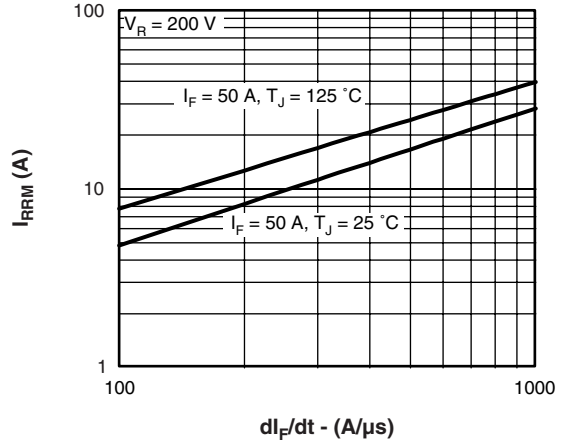

Fig. 7 - Typical Reverse Recovery Current vs. di_F/dt

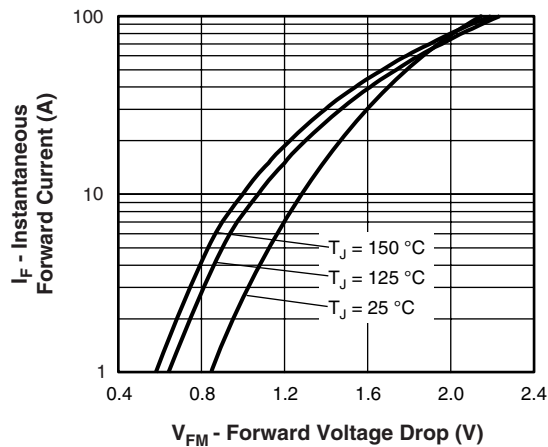

Fig. 5 - Maximum Forward Voltage Drop vs. Instantaneous Forward Current

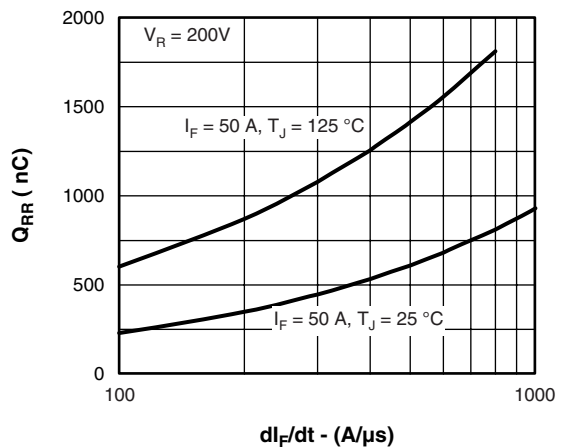

Fig. 8 - Typical Stored Charge vs. di_F/dt

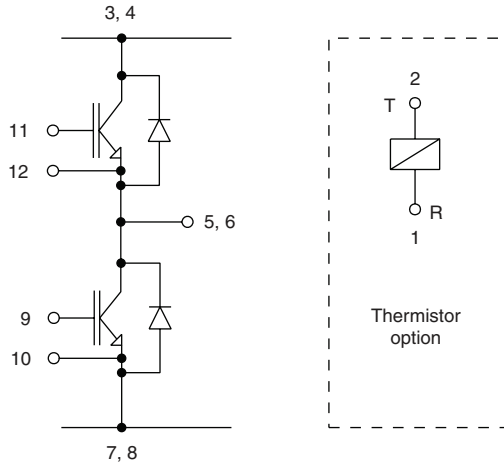

Fig. 9 - Functional Diagram

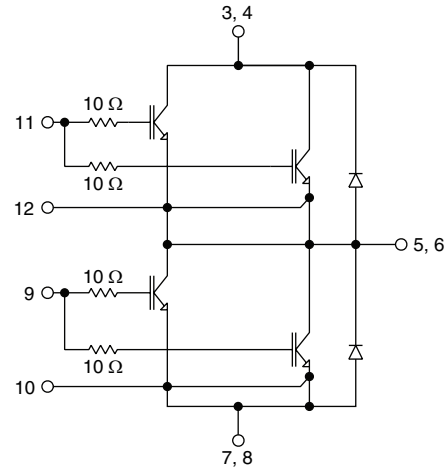
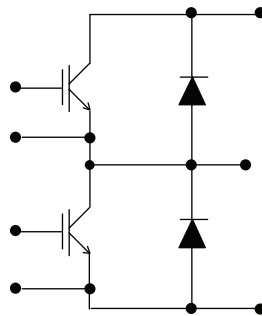

Fig. 10 - Electrical Diagram

ORDERING INFORMATION TABLE

Device code	50	MT	060	W	H	T	A	PbF
	①	②	③	④	⑤	⑥	⑦	⑧
	1	-	Current rating (50 = 50 A)					
	2	-	Essential part number					
	3	-	Voltage rating (060 = 600 V)					
	4	-	Speed/Type (W = Warp IGBT)					
	5	-	Circuit configuration (H = Half bridge)					
	6	-	T = Thermistor					
	7	-	A = Al ₂ O ₃ substrate					
	8	-	Lead (Pb)-free					

CIRCUIT CONFIGURATION

LINKS TO RELATED DOCUMENTS

Dimensions

<http://www.vishay.com/doc?95175>



Disclaimer

All product specifications and data are subject to change without notice.

Vishay Intertechnology, Inc., its affiliates, agents, and employees, and all persons acting on its or their behalf (collectively, "Vishay"), disclaim any and all liability for any errors, inaccuracies or incompleteness contained herein or in any other disclosure relating to any product.

Vishay disclaims any and all liability arising out of the use or application of any product described herein or of any information provided herein to the maximum extent permitted by law. The product specifications do not expand or otherwise modify Vishay's terms and conditions of purchase, including but not limited to the warranty expressed therein, which apply to these products.

No license, express or implied, by estoppel or otherwise, to any intellectual property rights is granted by this document or by any conduct of Vishay.

The products shown herein are not designed for use in medical, life-saving, or life-sustaining applications unless otherwise expressly indicated. Customers using or selling Vishay products not expressly indicated for use in such applications do so entirely at their own risk and agree to fully indemnify Vishay for any damages arising or resulting from such use or sale. Please contact authorized Vishay personnel to obtain written terms and conditions regarding products designed for such applications.

Product names and markings noted herein may be trademarks of their respective owners.