

SKN 130

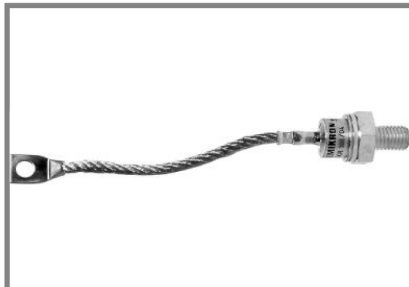

Stud Diode

Rectifier Diode

SKN 130

SKR 130

Features

- Reverse voltages up to 1800 V
- Hermetic metal case with glass insulator
- Threaded stud ISO M12 (also 1/2 - 20 UNF, 3/8 - 24 UNF and M12 x 1,5)
- SKN: anode to stud, SKR: cathode to stud

Typical Applications

- All-purpose mean power rectifier diodes
- Cooling via heatsinks
- Non-controllable and half-controllable rectifier
- Free-wheeling diodes
- Recommended snubber network:
RC: 0,25 μ F, 50 Ω , ($P_R = 2$ W),
 $R_P = 50$ k Ω ($P_R = 20$ W)

V_{RSM} V	V_{RRM} V	$I_{FRMS} = 260$ A (maximum value for continuous operation) $I_{FAV} = 130$ A (sin. 180; $T_c = 125$ °C)	
400	400	SKN 130/04	SKR 130/04
800	800	SKN 130/08	SKR 130/08
1200	1200	SKN 130/12	SKR 130/12
1400	1400	SKN 130/14	SKR 130/14
1600	1600	SKN 130/16	SKR 130/16
1800	1800	SKN 130/18	SKR 130/18

Symbol	Conditions	Values	Units
I_{FAV}	sin. 180; $T_c = 100$ °C	165	A
I_D	K 1,1; $T_a = 45$ °C; B2 / B6	160 / 225	A
	K 1,1F; $T_a = 35$ °C; B2 / B6	290 / 405	A
I_{FSM}	$T_{vj} = 25$ °C; 10 ms	2500	A
	$T_{vj} = 180$ °C; 10 ms	2000	A
i^2t	$T_{vj} = 25$ °C; 8,3 ... 10 ms	31000	A ² s
	$T_{vj} = 180$ °C; 8,3 ... 10 ms	20000	A ² s
V_F	$T_{vj} = 25$ °C; $I_F = 500$ A	max. 1,5	V
$V_{(TO)}$	$T_{vj} = 180$ °C	max. 0,85	V
r_T	$T_{vj} = 180$ °C	max. 1,3	m Ω
I_{RD}	$T_{vj} = 180$ °C; $V_{RD} = V_{RRM}$	max. 22	mA
Q_{rr}	$T_{vj} = 160$ °C; - $di_F/dt = 10$ A/ μ s	120	μ C
$R_{th(j-c)}$		0,35	K/W
$R_{th(c-s)}$		0,08	K/W
T_{vj}		- 40 ... + 180	°C
T_{stg}		- 55 ... + 180	°C
V_{isol}		-	V~
M_s	to heatsink	10	Nm
a		5 * 9,81	m/s ²
m	approx.	100	g
Case		E 14	

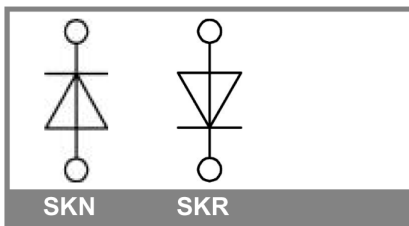

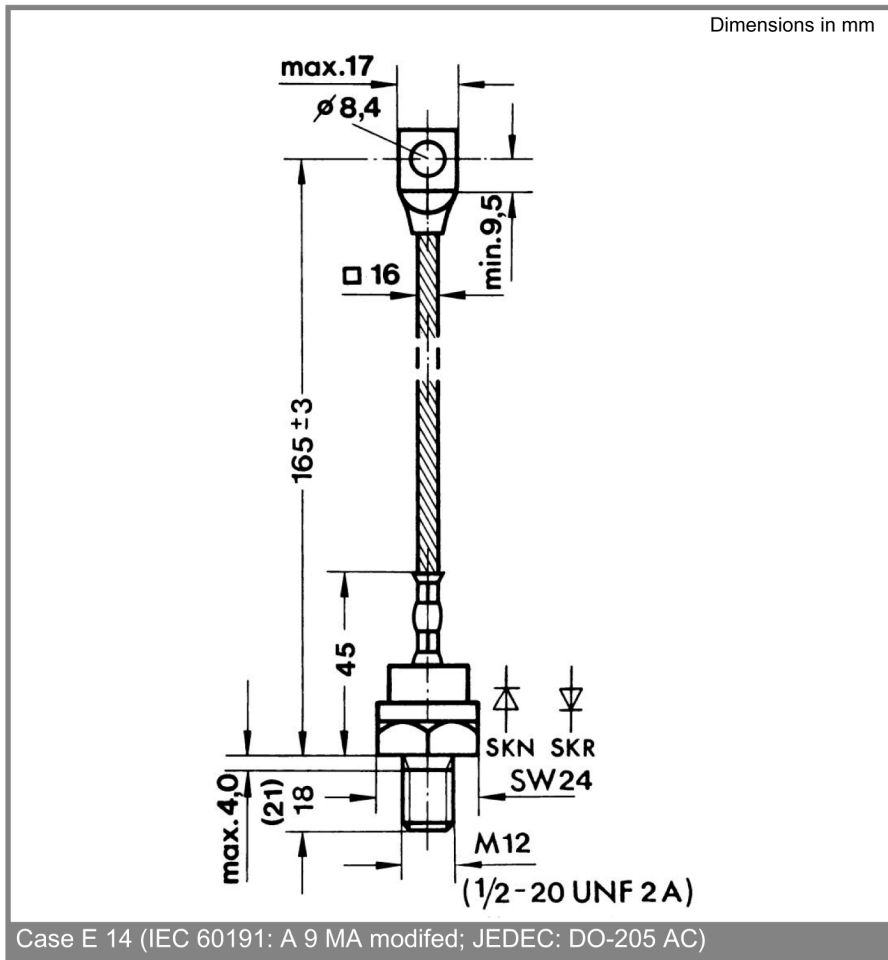

This technical information specifies semiconductor devices but promises no characteristics. No warranty or guarantee expressed or implied is made regarding delivery, performance or suitability.