

Description

Single pole high performance thermal-magnetic circuit breaker, with tease-free, trip-free, snap action mechanism and push/pull on/off actuation (M-type TM CBE to EN 60934). An indicator band on the push button clearly shows the tripped/off position. Threadneck panel mounted in tracked vehicle and aircraft/general purpose versions, with optional fast acting magnetic characteristics and auxiliary contacts.

Typical applications

Extra low voltage wiring systems on all types of vehicle for land, sea and air; defence equipment; battery powered machines.

Ordering information

Type No.	
452	standard delay curve
452-2	fast trip curve
Terminal design	
K14	screw terminals M6
K34	screw terminals M6, reinforced
Version	
FN2	vehicle application
LN2	aircraft/general application
Auxiliary contacts	
(blank)	without auxiliary contacts
S1	with auxiliary contact (connector EN 3155-016M2018 (NC))
S5	as S1, but with polarized auxiliary contact (NC)
Current ratings	
50...100 A	
452 - K14 - LN2 - S1 - 80 A	ordering example

Standard current ratings and typical volt drop values

Current rating (A)	Volt drop (mV)	Current rating (A)	Volt drop (mV)
50	90	80	92
60	85	90	100
70	85	100	100
75	90		

Approvals (without auxiliary contacts)

Authority	Voltage ratings	Current ratings
VG 95345, part 17	DC 28 V	60...100 A
QPL, Canada	DC 28 V	60...100 A
QPL, Sweden	DC 28 V	60...100 A (452-K34-FN)
UL	DC 28 V; DC 72 V	50...125 A



Technical data

Voltage rating	DC 28 V	
Current rating range	50...100 A	
Auxiliary circuit	0.5 A, DC 28 V	
Typical life	2,500 operations at I _N	
Ambient temperature	-55...+75 °C (-67...+167 °F)	
Insulation co-ordination (IEC 60664 and 60664A)	rated impulse withstand voltage 1.5 kV	pollution degree 3
Dielectric strength (IEC 60664 and 60664A) operating area	test voltage AC 1,500 V	
Insulation resistance	> 100 MΩ (DC 500 V)	
Interrupting capacity I _{cn}	6,000 A	
Degree of protection (IEC 60529/DIN 40050)	operating area IP40 terminal area IP00	
Vibration	10 g (55-2000 Hz), ± 0.76 mm (10-55 Hz) to VG 95210, sheet 19, IEC 60068-2-6, test Fc	
Shock	50 g (11 ms) to VG 95210, sheet 28, IEC 60068-2-27, test Ea	
Corrosion	96 hours at 5 % salt mist to VG 95210, sheet 2, IEC 60068-2-11, test Ka	
Humidity	240 hours at 95 % RH to VG 95210, sheet 7, IEC 60068-2-3, test C	
Explosion	to VG 95210, sheet 10, MIL-STD-202, meth. 109	
Mass	approx. 122 g without auxiliary contact approx. 126 g with auxiliary contact	

Dimensions 452-K...-...

452-K34-FN2 (VG 95345 T17)

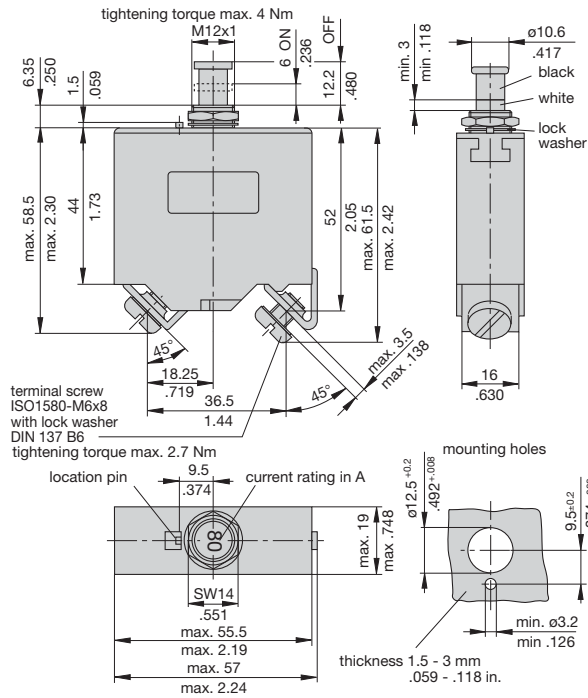

452-K14-LN2 (VG 95345 T17)

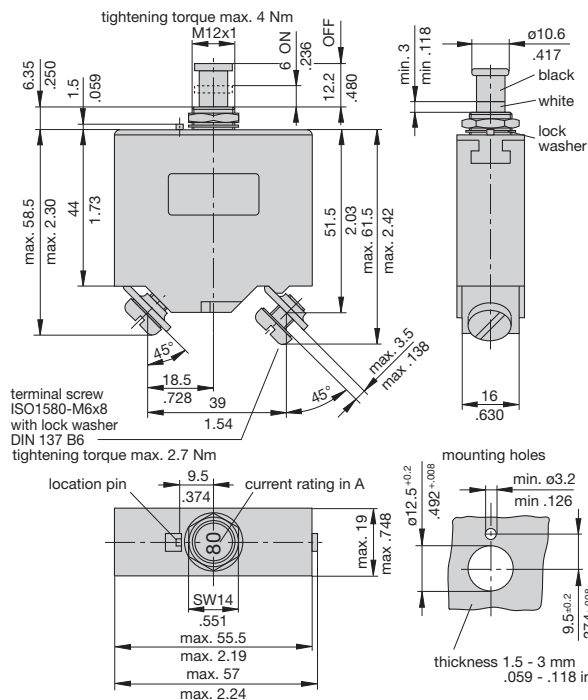

Dimensions 452-K...-S.

452-K34-LN2-S1 (VG 95345 T17) 452-K34-LN2-S5

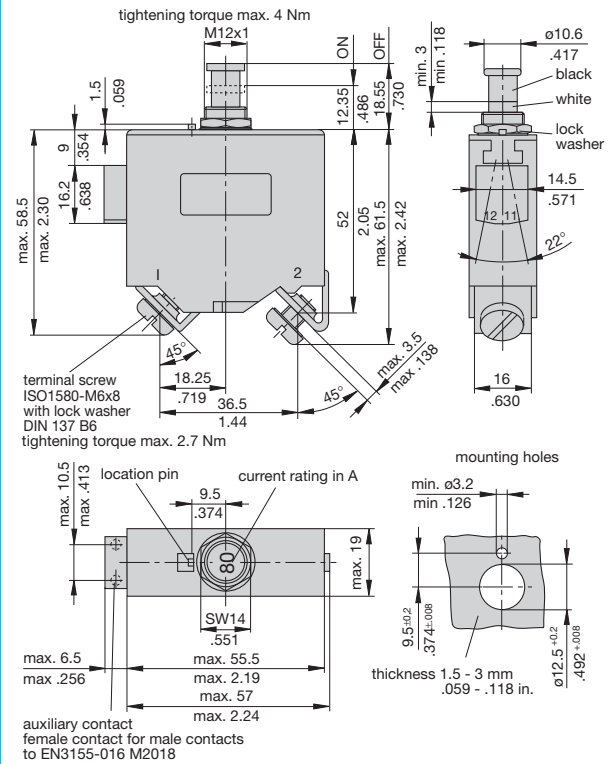

Internal connection diagram

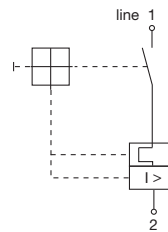

with auxiliary contact -S1

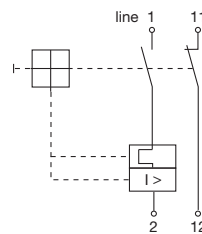

with polarized auxiliary contact -S5

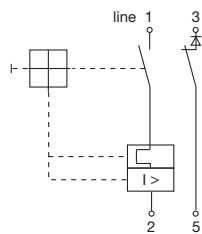

This is a metric design and millimeter dimensions take precedence ($\frac{mm}{inch}$)