

Universal LED in \varnothing 3 mm Tinted Diffused Package

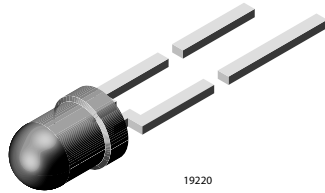

FEATURES

- For DC and pulse operation
- Luminous intensity categorized
- Standard \varnothing 3 mm (T-1) package
- Lead (Pb)-free device
- Component in acc. to RoHS 2002/95/EC and WEEE 2002/96/EC
- ESD-withstand voltage: up to 2 kV according to JESD22-A114-B



APPLICATIONS

- General indicating and lighting purposes

PARTS TABLE

PART	COLOR, LUMINOUS INTENSITY	ANGLE OF HALF INTENSITY ($\pm \phi$)	TECHNOLOGY
TLUR4400	Red, $I_V > 4$ mcd	30°	GaAsP on GaAs
TLUR4401	Red, $I_V = (4 \text{ to } 32)$ mcd	30°	GaAsP on GaAs

ABSOLUTE MAXIMUM RATINGS¹⁾, TLUR44..

PARAMETER	TEST CONDITION	SYMBOL	VALUE	UNIT
Reverse voltage ²⁾		V_R	6	V
DC Forward current		I_F	20	mA
Surge forward current	$t_p \leq 10 \mu\text{s}$	I_{FSM}	0.5	A
Power dissipation		P_V	60	mW
Junction temperature		T_J	100	°C
Operating temperature range		T_{amb}	- 40 to + 100	°C
Storage temperature range		T_{stg}	- 55 to + 100	°C
Soldering temperature	$t \leq 5$ s, 2 mm from body	T_{sd}	260	°C
Thermal resistance junction/ambient		R_{thJA}	500	K/W

Note:

¹⁾ $T_{amb} = 25$ °C unless otherwise specified

²⁾ Driving the LED in reverse direction is suitable for a short term application

OPTICAL AND ELECTRICAL CHARACTERISTICS ¹⁾ , TLUR44.., RED							
PARAMETER	TEST CONDITION	PART	SYMBOL	MIN	TYP.	MAX	UNIT
Luminous intensity	$I_F = 10 \text{ mA}$	TLUR4400	I_V	4	15		mcd
		TLUR4401	I_V	4		32	mcd
Dominant wavelength	$I_F = 10 \text{ mA}$		λ_d		630		nm
Peak wavelength	$I_F = 10 \text{ mA}$		λ_p		640		nm
Angle of half intensity	$I_F = 10 \text{ mA}$		φ		± 30		deg
Forward voltage	$I_F = 20 \text{ mA}$		V_F		2	3	V
Reverse voltage	$I_R = 10 \mu\text{A}$		V_R	6	15		V
Junction capacitance	$V_R = 0, f = 1 \text{ MHz}$		C_j		50		pF

Note:

¹⁾ $T_{amb} = 25 \text{ }^\circ\text{C}$ unless otherwise specified

LUMINOUS INTENSITY CLASSIFICATION		
GROUP	LIGHT INTENSITY [MCD]	
	STANDARD	MIN
P	4	8
Q	6.3	12.5
R	10	20
S	16	32
T	25	50
U	40	80
V	63	125
W	100	200
X	130	260
Y	180	360
Z	240	480

Note:

Luminous intensity is tested at a current pulse duration of 25 ms and an accuracy of $\pm 11 \%$.

The above type numbers represent the order groups which include only a few brightness groups. Only one group will be shipped on each bag (there will be no mixing of two groups on each bag).

In order to ensure availability, single brightness groups will not be orderable.

In a similar manner for colors where wavelength groups are measured and binned, single wavelength groups will be shipped on any one bag.

In order to ensure availability, single wavelength groups will not be orderable.

TYPICAL CHARACTERISTICS

$T_{amb} = 25 \text{ }^\circ\text{C}$ unless otherwise specified

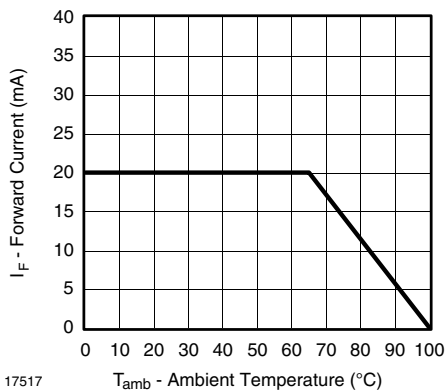

Figure 1. Forward Current vs. Ambient Temperature

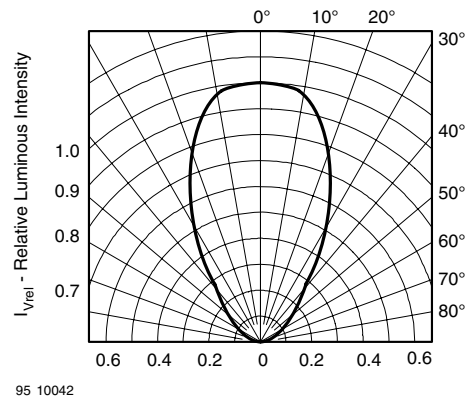

Figure 2. Rel. Luminous Intensity vs. Angular Displacement

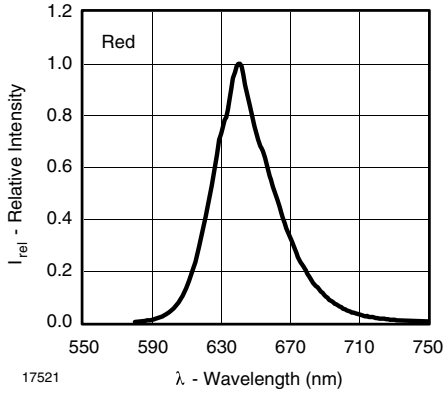

Figure 3. Relative Intensity vs. Wavelength

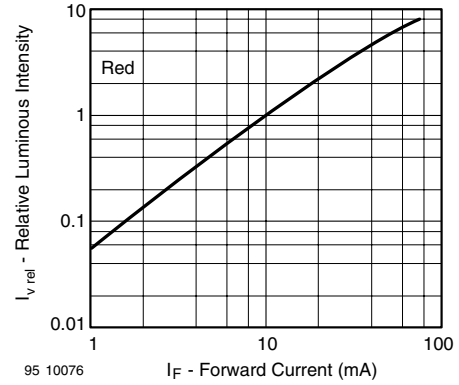

Figure 5. Relative Luminous Intensity vs. Forward Current

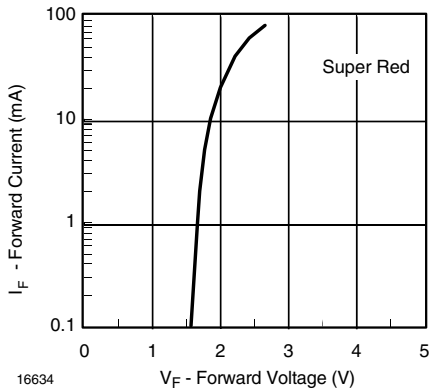

Figure 4. Forward Current vs. Forward Voltage

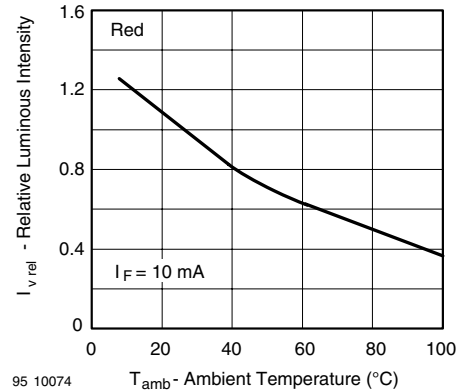
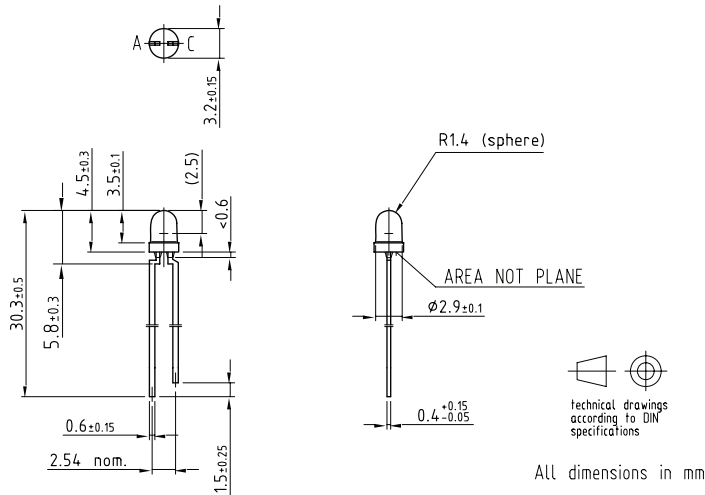

Figure 6. Rel. Luminous Intensity vs. Ambient Temperature

PACKAGE DIMENSIONS



Drawing-No.: 6.544-5255.01-4
Issue: 5; 08.11.99

95 10013