

Ledex® Rotary Solenoids Modifications and Custom Capabilities

Modifications and Customized Units

For modifications including heavy duty return springs, drive pins, etc. please contact our application engineers for assistance, as these standard modifications require a custom part number.

And, if you can't find exactly what you're looking for among our catalog products, please give our application engineers a call. Ledex custom fabricated solenoids are designed, built, tested, packaged, and shipped to your exact specifications. Whether it's as simple as adding a special connector or mounting bracket, or fabricating a complete assembly, we can build the right product to meet both your design and budget objectives.

Three Tapped Holes in Armature Plate

Attachment screws used should not extend below the bottom surface of the armature plate or they may interfere with the rotary stroke.

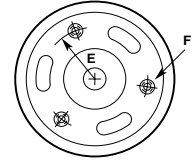

Solenoid Size	1E	2E	3B 3E	4E	5B 5S	6S	7S
Radius (E)	21/64	3/8	7/16	17/32	9/16	3/4	15/16
Thread Size (F)	#3-48	#3-48	#3-48	#5-40	#6-32	#8/32	#10-32

Return Springs

Scroll Type Standard or Heavy Duty Fixed Springs

The primary purpose of the return spring is to return the solenoid armature; it can also be used to return light loads. Standard nominal settings, which are accurate to within $\pm 20\%$, are charted below opposite "standard." Springs with greater torsion values can be supplied (see values opposite "Heavy Duty" below).

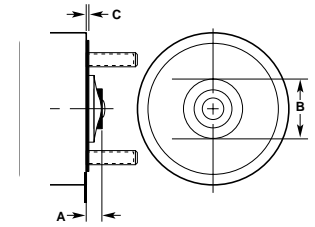

Solenoid Size	1E	2E	3B 3E	4E	5B 5S	6S	7S
Dim. A	5/32	5/32	11/64	13/64	7/32	1/4	5/16
Dim. B	35/64	35/64	43/64	13/16	7/8	1-1/32	1-11/64
Dim. C	1/64	1/64	1/64	1/32	1/32	1/32	1/32

Nominal Spring Setting: $\pm 20\%$ oz-in

Standard	1.0	1.0	2.0	3.0	4.0	8.0	12.0
Heavy Duty	—	—	2	4	5	8	16

Ledex® Rotary Solenoids Selection

How to Select Rotary Solenoids

1. Use the chart on page C9 to determine which coil style and frame size best satisfies your application requirement. Turn to the specification pages listed for model selection.

2. On the individual specification pages, use the Performance Chart (like the one shown at right), to select one of the five columns which provides the appropriate duty cycle for your application (for example 25%). Reading down this column locate the torque for the stroke you need.

3. Use the model number and configuration chart (like the one at the bottom of this page) to select the model number corresponding to your desired design, stroke, and direction of rotation.

4. Using the Coil Specification Chart (like the one at right), find your selected duty cycle column. Reading down this column provides a variety of specification data. Following further down the column into the VDC ratings, select the voltage which most closely matches your supply voltage (for example, for a 24 VDC supply, select 26.0). Read across to the left to select the coil awg suffix for this voltage.

5. Replace the last two digits of the model number (XX) with the coil awg number to complete the model number. (For this example, specify model number: H-15039-033.)

Performance Specifications

Stroke	Holding Torque ² (lb-in)	Starting Torque (lb-in) @ 20°C				
		Maximum Duty Cycle				
		100%	50%	25%	10%	5%
25°	0.28	*	0.2	0.4	0.8	1.1
35°	*	*	*	*	*	*
45°	0.15	*	0.1	0.2	0.4	0.6

Coil Specifications

Maximum Duty Cycle	100%	50%	25%	10%	5%
Maximum ON Time (sec) when pulsed continuously	∞	100	36	7	2.5
Maximum ON Time (sec) for single pulse	∞	162	44	8	2.8
Watts (@ 20°C)	*	10.5	21	54	108
Ampere Turns (@ 20°C)	*	492	695	1,105	1560

Coil Data

awg (0XX)	Resistance (@20°C)	# Turns	VDC (Nom)	VDC (Nom)	VDC (Nom)	VDC (Nom)	VDC (Nom)
25	0.83	140	*	2.9	4.1	6.5	9.2
26	1.38	186	*	3.7	5.2	8.2	11.6
27	1.91	210	*	4.5	6.3	10.1	14.2
28	3.17	273	*	5.7	8.1	12.8	18.1
29	5.17	352	*	7.2	10.2	16.2	23.0
30	8.25	441	*	9.2	13.0	21.0	29.0
31	12.95	550	*	11.6	16.4	26.0	37.0
32	20.71	682	*	14.9	21.0	34.0	47.0
33	30.60	828	*	18.2	26.0	41.0	58.0
34	50.95	1078	*	23.0	33.0	52.0	74.0
35	83.92	1392	*	30.0	42.0	67.0	94.0

- Armature cover
- Armature end shaft
- Return Spring

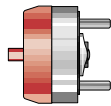

- Armature cover
- Base end shaft
- Return spring

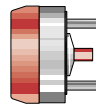

- Armature cover
- Double shaft
- Return spring

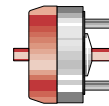

Stroke/Direction*	Nom. Axial Stroke	Standard		Long Life		Standard		Long Life	
		Standard	Long Life	Standard	Long Life	Standard	Long Life		
25°CW	0.025"	H-1142-0XX	L-1142-0XX	H-1140-0XX	L-1140-0XX	H-15097-0XX	L-15097-0XX	H-3334-0XX	L-3334-0XX
25°CCW	0.025"	H-1145-0XX	L-1145-0XX	H-1144-0XX	L-1144-0XX	H-15207-0XX	L-15207-0XX	H-15208-0XX	L-15208-0XX
35°CW	0.030"	H-15201-0XX	L-15201-0XX	H-15205-0XX	L-15205-0XX	H-15207-0XX	L-15207-0XX	H-15208-0XX	L-15208-0XX
35°CCW	0.030"	H-15202-0XX	L-15202-0XX	H-15206-0XX	L-15206-0XX	H-15207-0XX	L-15207-0XX	H-15208-0XX	L-15208-0XX
45°CW	0.025"	H-1148-0XX	L-1148-0XX	H-1147-0XX	L-1147-0XX	H-15039-0XX	L-15039-0XX	H-15148-0XX	L-15148-0XX
45°CCW	0.025"	H-1150-0XX	L-1150-0XX	H-1149-0XX	L-1149-0XX	H-15148-0XX	L-15148-0XX	H-15148-0XX	L-15148-0XX

*Direction of rotation (cw – clockwise or ccw – counterclockwise) is viewed from the armature end of the solenoid opposite the mounting studs.

Note: The XX in the part number suffix must be filled in with the awg of your choice.

Ledex® Rotary Solenoids Selection

Rotary Solenoids Selection Overview

Size/ Series	Diameter ¹ (inches)	Height ¹ (inches)	Stroke	Direction CW CCW		Holding Torque (lb-in)	Available Torque ² (lb-in)					Energizing Time (msec) @ Specified Duty Cycles					Return Spring (lb-in)	
							100% Duty	50% Duty	25% Duty	10% Duty	5% Duty	100% Duty	50% Duty	25% Duty	10% Duty	5% Duty		
1E	1.000	0.625	25°	•	•	0.3	*	0.2	0.4	0.8	1.1	12.6	9.9	7.3	5.7	4.7	0.06	
			35°	•	•	*	*	*	*	*	*	*	*	*	*	*	*	*
			45°	•	•	0.2	*	0.1	0.2	0.4	0.6	19.8	14.2	10.0	7.2	6.0	0.06	
2E	1.125	0.656	25°	•	•	0.5	0.2	0.4	0.7	1.4	1.7	13.1	9.5	7.5	5.9	5.0	0.06	
			35°	•	•	*	0.2	0.3	0.5	1.1	1.3	*	*	*	*	*	*	
			45°	•	•	0.3	0.1	0.2	0.4	0.7	0.9	23.2	15.0	11.0	8.4	7.0	0.06	
3B	1.312	0.875	25°	•	•	0.9	0.4	0.7	1.3	2.7	3.2	16.5	11.3	8.9	6.8	5.9	0.12	
			35°	•	•	0.6	0.3	0.6	1.0	2.0	2.3	*	*	*	*	*	*	
			45°	•	•	0.4	0.2	0.4	0.8	1.4	1.7	24.0	15.6	12.1	9.4	7.7	0.12	
			67½°	•	•	0.4	0.1	0.2	0.4	0.5	0.8	*	*	*	*	*	*	
3E	1.312	0.797	25°	•	•	0.9	0.4	0.8	1.4	2.7	3.2	16.9	12.0	9.3	7.1	6.2	0.12	
			35°	•	•	0.7	0.3	0.6	1.0	2.0	2.3	*	*	*	*	*	*	
			45°	•	•	0.6	0.2	0.4	0.8	1.4	1.8	29.8	17.8	13.1	10.0	8.1	0.12	
			67½°	•	•	0.5	0.1	0.2	0.4	0.7	0.9	*	*	*	*	*	*	
4E	1.562	0.953	25°	•	•	2.0	0.9	1.7	3.1	4.5	5.2	19.1	13.9	11.2	8.3	7.2	0.18	
			35°	•	•	*	0.6	1.1	2.0	3.1	3.5	*	*	*	*	*	*	
			45°	•	•	1.0	0.4	0.9	1.6	2.6	3.1	28.9	20.3	15.4	11.3	9.2	0.18	
			55°	•	•	*	*	*	*	*	*	*	*	*	*	*	*	
			67½°	•	•	*	0.2	0.4	0.8	1.6	1.9	*	*	*	*	*	*	
5B	1.875	1.203	25°	•	•	4.0	1.8	3.5	5.8	8.3	10.0	19.6	14.9	12.0	9.4	7.7	0.25	
			35°	•	•	*	0.9	2.1	4.1	6.9	8.3	*	*	*	*	*	*	
			45°	•	•	3.0	0.7	1.7	3.2	5.0	6.0	29.0	21.2	16.5	12.6	10.2	0.25	
			67½°	•	•	*	0.5	1.1	2.0	3.3	4.0	*	*	*	*	*	*	
			95°	•	•	2.0	0.2	0.4	0.9	1.6	1.9	*	*	*	*	*	*	
5S	1.875	1.047	25°	•	•	5.0	1.9	4.1	7.3	12.1	13.2	18.6	14.3	11.5	9.0	7.2	0.25	
			35°	•	•	*	1.2	2.6	4.5	7.8	9.2	*	*	*	*	*	*	
			45°	•	•	3.0	0.7	1.7	3.4	6.3	6.9	28.1	20.3	15.6	12.0	10.0	0.25	
			55°	•	•	*	*	*	*	*	*	*	*	*	*	*	*	
			67½°	•	•	*	0.5	1.2	2.2	3.9	4.9	*	*	*	*	*	*	
			75°	•	•	*	*	*	*	*	*	*	*	*	*	*	*	
			95°	•	•	2.0	0.2	0.5	1.0	1.9	2.6	62.4	36.5	26.1	18.7	15.0	0.25	
6S	2.250	1.343	25°	•	•	9.0	4.6	8.9	16.2	27.8	30.6	24.1	18.6	14.8	11.4	9.5	0.50	
			35°	•	•	*	3.4	6.5	12.0	18.6	20.5	*	*	*	*	*	*	
			45°	•	•	6.0	1.7	3.5	6.5	11.0	12.1	38.1	27.4	21.6	16.5	13.5	0.50	
			55°	•	•	*	*	*	*	*	*	*	*	*	*	*	*	
			67½°	•	•	*	1.6	3.1	5.6	8.8	9.7	*	*	*	*	*	*	
			95°	•	•	3.0	0.9	1.7	3.3	5.2	5.7	*	*	*	*	*	*	
			110°	•	•	*	*	*	*	*	*	*	*	*	*	*	*	
7S	2.750	1.766	25°	•	•	20.0	11.0	23.8	33.2	42.4	46.6	32.3	25.1	20.3	15.6	13.2	0.75	
			35°	•	•	*	6.0	12.0	22.0	38.0	42.0	*	*	*	*	*	*	
			45°	•	•	13.0	5.0	8.8	16.4	29.8	32.8	45.1	33.9	27.2	20.2	16.9	0.75	
			55°	•	•	*	*	*	*	*	*	*	*	*	*	*	*	
			67½°	•	•	*	2.5	5.1	9.8	17.5	19.3	*	*	*	*	*	*	
95°	•	•	6.0	1.5	3.5	6.4	10.5	11.6	81.6	58.8	44.8	33.0	27.3	0.75				

All data is at 20°C coil temperature. Torque outputs degrade with elevated temperatures.

¹ Without armature cover

² Torque values and energizing times shown for S and E Series are for Standard Life units. Long Life models provide approximately 10% less torque, but offer 5 to 10 times longer life. Long Life models are only available in strokes up to 45°.

* Consult factory for sizes and strokes not shown.

All specifications subject to change without notice.

Ledex® Rotary Solenoids Size 1E Precision Elongated Coil

Performance Specifications

Stroke	Holding Torque ² (lb-in)	Starting Torque (lb-in) ¹ @ 20°C Maximum Duty Cycle				
		100%	50%	25%	10%	5%
25°	0.28	*	0.2	0.4	0.8	1.1
35°	*	*	*	*	*	*
45°	0.15	*	0.1	0.2	0.4	0.6

All data is at 20°C coil temperature. Force (torque) outputs degrade with elevated temperatures.

¹ Gross starting torques are shown. For net available starting torque, subtract return spring torque of 0.06 lb.-in. ±20%.

² Holding torque is shown at the stabilized temperature of 105°C and continuous duty.

* Consult factory.

How to Order

- Using the Performance Chart to the left, select one of the five columns which provides the appropriate duty cycle for your application. Reading down this column locate the torque for the stroke you need. For net available starting torque, subtract return spring torque of 0.06 lb.-in. ±20% (if torque is insufficient go to next larger solenoid size).
- Use the chart below to select the model number corresponding to your desired design, stroke and direction of rotation (as viewed from armature end, opposite mounting studs).
- Using the Specification Chart to the right, select the same duty cycle column. Follow down the column into the VDC ratings. Select the voltage which most closely matches your supply voltage. Read across to the left to select the coil awg suffix.
- Replace the last two digits of the model number (XX) with the coil awg number to complete the part number.

Please see www.ledex.com (click on Stock Products tab) for our list of stock products available through our North American distributors.

- Armature cover
- Armature end shaft
- Return spring

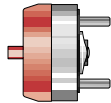

- Armature cover
- Base end shaft
- Return spring

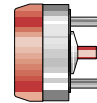

- Armature cover
- Double shaft
- Return spring

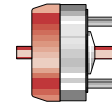

Stroke/ Direction*	Nom. Axial Stroke	Standard		Long Life		Standard		Long Life	
		Standard	Long Life	Standard	Long Life	Standard	Long Life		
25° CW	0.025"	H-1142-0XX	L-1142-0XX	H-1140-0XX	L-1140-0XX	H-15097-0XX	L-15097-0XX	H-3334-0XX	L-3334-0XX
25° CCW	0.025"	H-1145-0XX	L-1145-0XX	H-1144-0XX	L-1144-0XX	H-15207-0XX	L-15207-0XX	H-15208-0XX	L-15208-0XX
35° CW	0.030"	H-15201-0XX	L-15201-0XX	H-15205-0XX	L-15205-0XX	H-15207-0XX	L-15207-0XX	H-15208-0XX	L-15208-0XX
35° CCW	0.030"	H-15202-0XX	L-15202-0XX	H-15206-0XX	L-15206-0XX	H-15207-0XX	L-15207-0XX	H-15208-0XX	L-15208-0XX
45° CW	0.025"	H-1148-0XX	L-1148-0XX	H-1147-0XX	L-1147-0XX	H-15039-0XX	L-15039-0XX	H-15148-0XX	L-15148-0XX
45° CCW	0.025"	H-1150-0XX	L-1150-0XX	H-1149-0XX	L-1149-0XX	H-15039-0XX	L-15039-0XX	H-15148-0XX	L-15148-0XX

* Direction of rotation (cw – clockwise or ccw – counterclockwise) is viewed from the armature end of the solenoid opposite the mounting studs.

Note: The XX in the part number suffix must be filled in with the awg of your choice.

Ledex® Rotary Solenoids Size 1E Precision Elongated Coil

Coil Specifications

Maximum Duty Cycle	100%	50%	25%	10%	5%
Maximum ON Time (sec) when pulsed continuously ¹	∞	100	36	7	2.5
Maximum ON Time (sec) for single pulse ²	∞	162	44	8	2.8
Watts (@ 20°C)	*	10.5	21	54	108
Ampere Turns (@ 20°C)	*	492	695	1105	1560

Coil Data

awg (0XX) ³	Resistance (@20°C)	# Turns ⁴	VDC (Nom)	VDC (Nom)	VDC (Nom)	VDC (Nom)	VDC (Nom)
25	0.83	140	*	2.9	4.1	6.5	9.2
26	1.38	186	*	3.7	5.2	8.2	11.6
27	1.91	210	*	4.5	6.3	10.1	14.2
28	3.17	273	*	5.7	8.1	12.8	18.1
29	5.17	352	*	7.2	10.2	16.2	23.0
30	8.25	441	*	9.2	13.0	21.0	29.0
31	12.95	550	*	11.6	16.4	26.0	37.0
32	20.71	682	*	14.9	21.0	34.0	47.0
33	30.60	828	*	18.2	26.0	41.0	58.0
34	50.95	1078	*	23.0	33.0	52.0	74.0
35	83.92	1392	*	30.0	42.0	67.0	94.0

General Specifications

Dielectric Strength	1000 VRMS, all coils
Recommended Minimum Heat Sink	Maximum watts dissipated by solenoid are based on an unrestricted flow of air at 20°C, with solenoid mounted on the equivalent of an aluminum plate measuring 3" square by 1/8" thick.
Coil Resistance	±5% tolerance
Starting Torque	Gross torque values are shown. For net starting torque, subtract return spring torque
Return Spring Torque	0.06 pound-inches ±20%
Weight	1.5 oz (42.5 gms)
Dimensions	See page C28

- ¹ Continuously pulsed at stated watts and duty cycle.
 - ² Single pulse at stated watts (with coil at ambient room temperature 20°C).
 - ³ Other coil awg sizes available, consult factory.
 - ⁴ Reference number of turns.
- * Consult factory.

All specifications subject to change without notice.

- No shafts
- 3 tapped holes
- Return spring

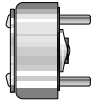

- Armature end shaft
- 3 tapped holes
- Return spring

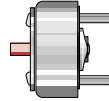

- Base end shaft
- 3 tapped holes
- Return spring

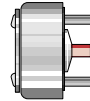

- Double shaft
- 3 tapped holes
- Return spring

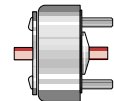

Standard	Long Life	Standard	Long Life	Standard	Long Life	Standard	Long Life
H-1143-0XX	L-1143-0XX	H-15089-0XX	L-15089-0XX	H-15211-0XX	L-15211-0XX	H-15215-0XX	L-15215-0XX
H-1146-0XX	L-1146-0XX	H-3311-0XX	L-3311-0XX	H-15084-0XX	L-15084-0XX	H-15216-0XX	L-15216-0XX
H-15200-0XX	L-15200-0XX	H-15204-0XX	L-15204-0XX	H-15212-0XX	L-15212-0XX	H-1305-0XX	L-1305-0XX
H-15203-0XX	L-15203-0XX	H-15210-0XX	L-15210-0XX	H-15213-0XX	L-15213-0XX	H-15217-0XX	L-15217-0XX
H-1141-0XX	L-1141-0XX	H-3380-0XX	L-3380-0XX	H-15085-0XX	L-15085-0XX	H-15218-0XX	L-15218-0XX
H-1151-0XX	L-1151-0XX	H-1282-0XX	L-1282-0XX	H-15214-0XX	L-15214-0XX	H-15219-0XX	L-15219-0XX

Ledex® Rotary Solenoids 1E Dimensions

Inches (mm)

Armature Cover Configuration — Armature End Shaft

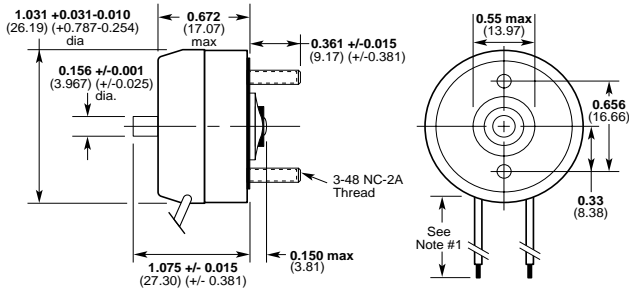

Armature Cover Configuration — Base End Shaft

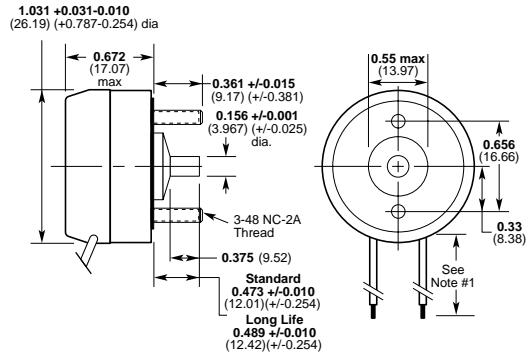

Armature Cover Configuration — Double Shaft

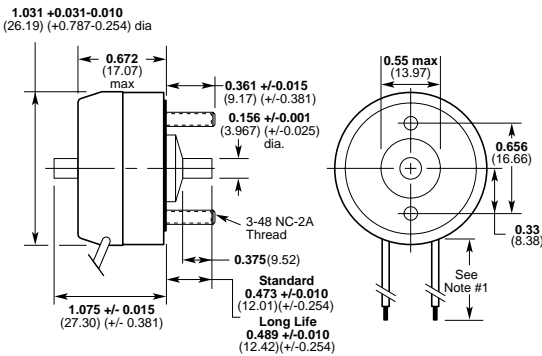

Notes:

- 1) All configurations have 10" (254 mm) minimum leads, 24 awg, PVC insulation.
- 2) For electrical specs and performance charts, see pages C10-C11.

All specifications subject to change without notice.

No Shaft

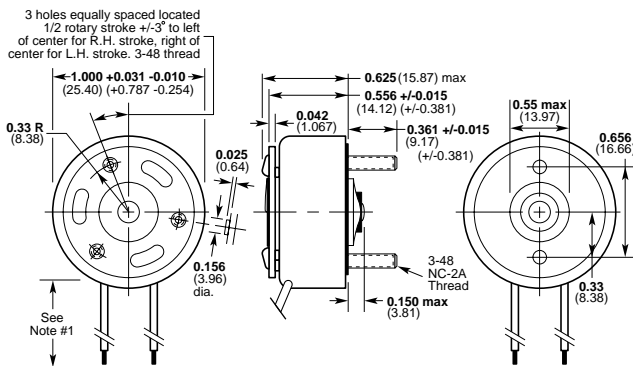

Base End Shaft

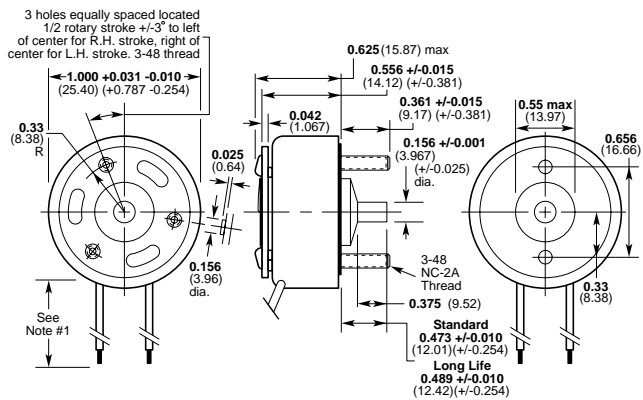

Armature End Shaft

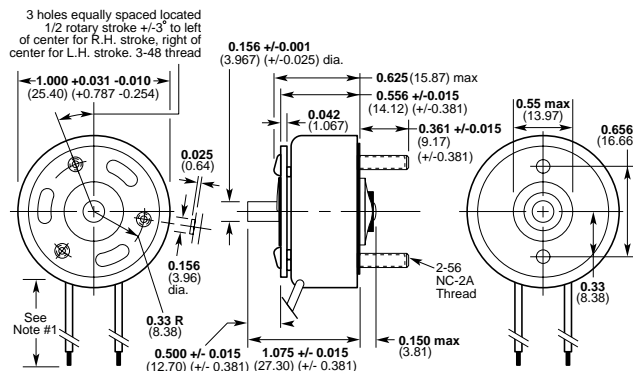

Double Shaft

