

[Home](#) > Product Details

ZUS15



Features

- UL recognized, TV approved, CSA certified
- Isolated between input-output
- Thin profile
- Built-in Over Current Protection
- RoHS Compliant

5 year warranty(refer to Instruction Manual)

Model	Input Voltage [V]	Output Wattage [W]	DC Output [V/A]
ZUS15053R3	DC 4.5 - 9	6.6	3.3V 2A
ZUS150505	DC 4.5 - 9	10	5V 2A
ZUS150512	DC 4.5 - 9	12	12V 1A
ZUS151205	DC 9 - 18	12	5V 2.4A
ZUS151212	DC 9 - 18	15.6	12V 1.3A
ZUS152405	DC 18 - 36	12	5V 2.4A
ZUS152412	DC 18 - 36	15.6	12V 1.3A
ZUS15483R3	DC 36 - 75	7.92	3.3V 2.4A
ZUS154805	DC 36 - 75	12	5V 2.4A
ZUS154812	DC 36 - 75	15.6	12V 1.3A

- ① Series name
- ② Single output
- ③ Output wattage
- ④ Input voltage
- ⑤ Output voltage

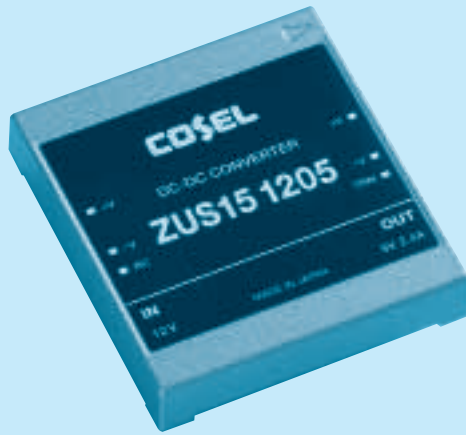

MODEL	ZUS15053R3	ZUS150505	ZUS150512	ZUS151205	ZUS151212	ZUS152405	ZUS152412	ZUS15483R3	ZUS154805	ZUS154812	
MAX OUTPUT WATTAGE[W]	6.6	10.0	12.0	12.0	15.6	12.0	15.6	7.92	12.0	15.6	
DC OUTPUT	VOLTAGE[V]	3.3	5	12	5	12	5	12	3.3	5	12
	CURRENT[A]	2.0	2.0	1.0	2.4	1.3	2.4	1.3	2.4	2.4	1.3

SPECIFICATIONS

	MODEL	ZUS15053R3	ZUS150505	ZUS150512	ZUS151205	ZUS151212	ZUS152405	ZUS152412	ZUS15483R3	ZUS154805	ZUS154812	
INPUT	VOLTAGE[V]	DC4.5 - 9			DC9 - 18		DC18 - 36		DC36 - 75			
	CURRENT[A]	*1 1.83typ	2.50typ	2.96typ	1.25typ	1.57typ	0.63typ	0.78typ	0.21typ	0.31typ	0.39typ	
	EFFICIENCY[%]	*1 72typ	80typ	81typ	80typ	83typ	80typ	83typ	78typ	80typ	83typ	
OUTPUT	VOLTAGE[V]	3.3	5	12	5	12	5	12	3.3	5	12	
	CURRENT[A]	2.0	2.0	1.0	2.4	1.3	2.4	1.3	2.4	2.4	1.3	
	LINE REGULATION[mV]	20max	20max	48max	20max	48max	20max	48max	20max	20max	48max	
	LOAD REGULATION[mV]	40max	40max	100max	40max	100max	40max	100max	40max	40max	100max	
	RIPPLE[mVp-p]	*2 80max	80max	120max	80max	120max	80max	120max	80max	80max	120max	
	RIPPLE NOISE[mVp-p]	*2 120max	120max	150max	120max	150max	120max	150max	120max	120max	150max	
	TEMPERATURE REGULATION[mV] 0 to +55°C	50max	50max	150max	50max	150max	50max	150max	50max	50max	150max	
	DRIFT[mV]	*3 20max	20max	48max	20max	48max	20max	48max	20max	20max	48max	
	START-UP TIME[ms]	100max (Minimum input, Io=100%)										
	OUTPUT VOLTAGE ADJUSTMENT RANGE[V]	Internally fixed (TRM pin open), adjustable by external VR										
OUTPUT VOLTAGE SETTING[V]	3.20 - 3.47	±5%						3.20 - 3.47	±5%			
OVERCURRENT PROTECTION	Works over 105% of rating and recovers automatically											
OVERVOLTAGE PROTECTION	4.0 - 5.25V	Works at 115 - 140% of rating							4.0 - 5.25V	Works at 115 - 140% of rating		
REMOTE ON/OFF	Between RC and -side of input:short - 1.2V · · · output ON, 2.4V - 5.5V(or open) · · · output OFF, Compatible to TTL											
ISOLATION	INPUT-OUTPUT	AC500V 1minute, Cutoff current = 10mA, DC500V 50MΩ min (20±15°C)										
	INPUT-CASE	AC500V 1minute, Cutoff current = 10mA, DC500V 50MΩ min (20±15°C)										
	OUTPUT-CASE	AC500V 1minute, Cutoff current = 10mA, DC500V 50MΩ min (20±15°C)										
ENVIRONMENT	OPERATING TEMP.,HUMID.AND ALTITUDE	-20 to +71°C, 20 - 95%RH (Non condensing) (Refer to DERATING CURVE), 3,000m (10,000feet) max										
	STORAGE TEMP.,HUMID.AND ALTITUDE	-40 to +85°C, 20 - 95%RH (Non condensing), 9,000m (30,000feet) max										
	VIBRATION	10 - 55Hz, 98.0m/s ² (10G), 3minutes period, 60minutes each along X, Y and Z axis										
	IMPACT	490.3m/s ² (50G), 11ms, once each X, Y and Z axis										
SAFETY	AGENCY APPROVALS	UL60950-1, EN60950-1, CSA C22.2 No.234 Complies with IEC60950-1										
OTHERS	CASE SIZE/WEIGHT	45 × 8.5 × 50mm (W × H × D) / 55g max										
	COOLING METHOD	Convection										

*1 Rated input. 5V, 12V, 24V or 48V DC, Io=100%

*2 Measured by 20MHz oscilloscope.

*3 The drift is a change at 25°C of ambient temperature and 30 minutes - 8 hours after the input voltage applied at rated input/output.

* Series/Parallel operation with other model is not possible.

External view

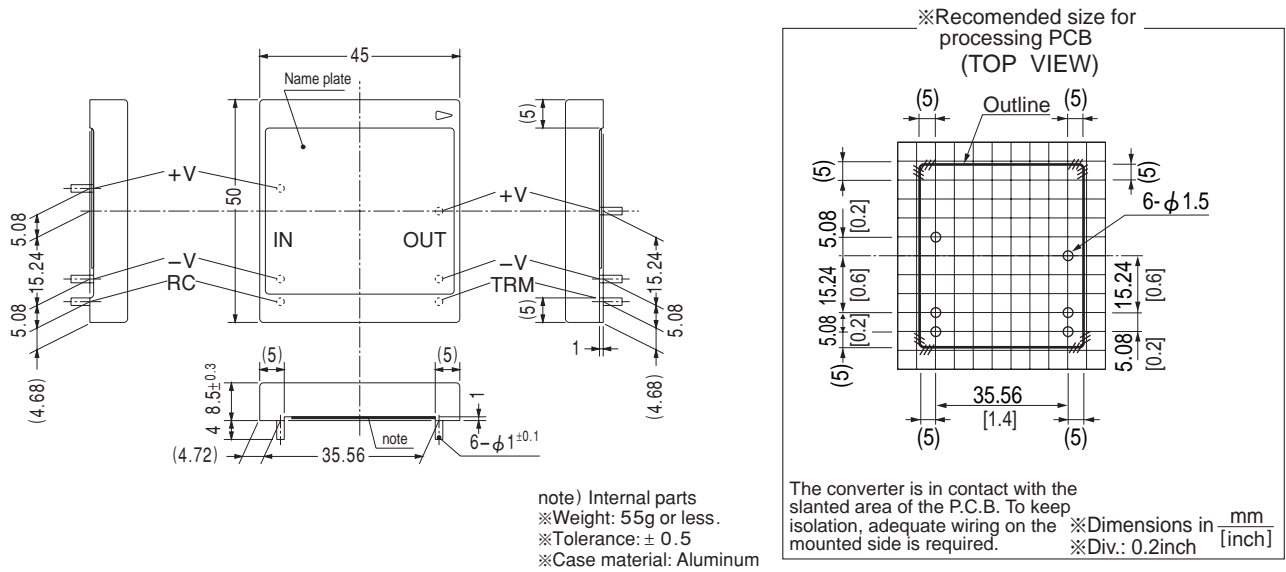

Performance data

■STATIC CHARACTERISTICS (ZUS151205)

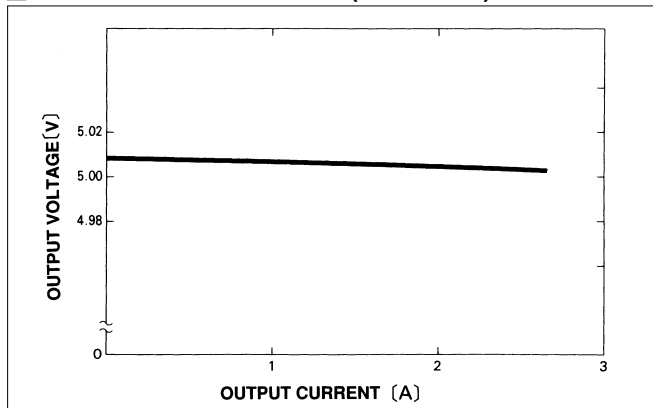

■RISE TIME & FALL TIME (ZUS151205)

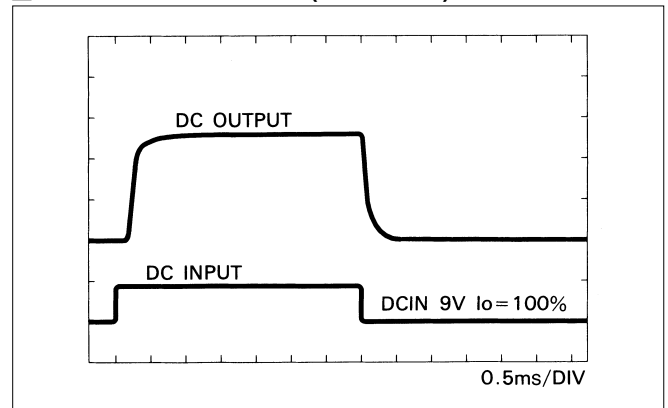

■OVERCURRENT CHARACTERISTICS (ZUS151205)

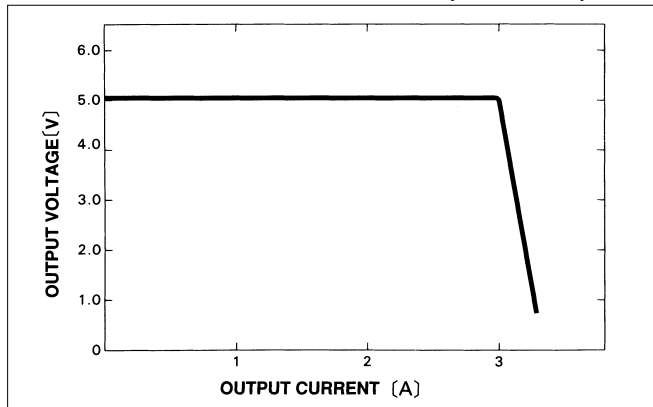

■DERATING CURVE

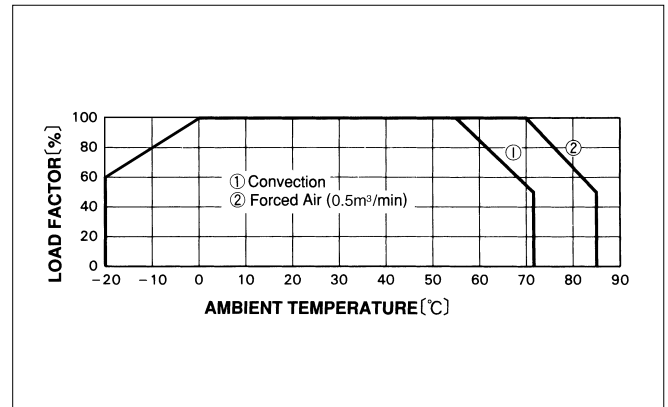

ZUS15