

**Type: 3130-F**



Single, two and three pole rocker switch/thermal trip free circuit breakers (S-type TO CBE to EN 60934) of compact design for snap-in panel mounting. Available either with protection on one/both/all poles or, in the case of the double pole version, protection on one pole only. Illumination is optional and there is a choice of rocker colours. Approved to CBE standard EN 60934 (IEC 60934).

**Voltage rating:**

- 3 AC 415 V
- AC 240 V
- DC 50 V
- UL/CSA: 3 AC 250 V
- UL/CSA: AC 250 V

**Current ratings:**

from 0.1 A to 20 A 1 pole  
from 0.1 A to 16 A 2 and 3 pole

**Number of poles:**

single pole  
double pole  
three pole

**Mounting method:**

flange

**Terminal design:**

blade terminals  
screw terminals

**Actuation:**

rocker

**Auxiliary contacts:**

without auxiliary contacts

**Water splash protection:**

with water splash protection  
without water splash protection

**Illumination:**

with illumination  
without illumination

**Typical life:**

30,000 operations at  $1 \times I_N$ , inductive, 1 and 3 pole  
50,000 operations at  $1 \times I_N$ , inductive, 2 pole

**Interrupting capacity  $I_{cn}$ :**

0.1...2 A:  $10 \times I_N$   
2.5...20 A: 150 A 1 pole  
2.5...16 A: 250 A 2 pole  
2.5...12 A: 150 A 3 pole  
14...16 A: 130 A 3 pole

**Approvals:**

VDE, UL, CSA

**Dimensions**

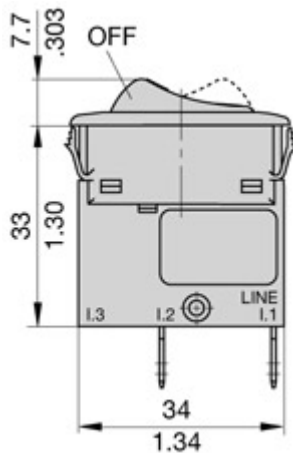

**Internal connection diagrams**

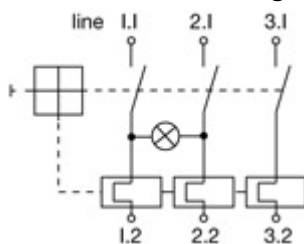

## Description

Single, two and three pole rocker switch/thermal trip free circuit breakers (S-type TO CBE to EN 60934) of compact design for snap-in panel mounting. Available either with protection on one/both/all poles or, in the case of the double pole version, protection on one pole only. Illumination is optional and there is a choice of rocker colours. Approved to CBE standard EN 60934 (IEC 60934).

## Typical applications

Motors, transformers, solenoids, household and office machines, electrical tools, mobile homes, boating, construction vehicles, medical equipment to EN 60601.

## Standard current ratings and typical internal resistance values

Current rating (A)	Internal resistance per pole ( $\Omega$ )	Current rating (A)	Internal resistance per pole ( $\Omega$ )
0.1	94	4	0.0435
0.2	24	5	0.0325
0.3	12	6	0.0215
0.4	5.30	7	0.0165
0.5	4.20	8	0.0165
0.8	1.50	10	< 0.02
1	0.9	12	< 0.02
1.2	0.80	14	< 0.02
1.5	0.45	15	< 0.02
2	0.27	16	< 0.02
2.5	0.0785	18	< 0.02
3	0.0595	20	< 0.02
3.5	0.0565		

## Illumination voltage/power consumption

operating voltage	power consumption	
	filament/neon (B)	LED (G, R, Y)
6 V	60 mA	9 mA
12 V	20 mA	9 mA
24 V	20 mA	9 mA
48 V	20 mA	1.5 mA
115 V	< 1.5 mA	< 1 mA*
230 V	< 1.5 mA	< 1 mA*
415 V	< 1 mA	not available

\* single pole version only

## Approvals

Authority	Voltage rating	Current rating
VDE (EN 60934)	AC 240/415 V	0.1...20 A single pole 0.1...16 A multipole
	DC 50 V	0.1...8 A single pole 0.1...16 A multipole
	DC 28 V	0.1...20 A single pole
UL, CSA	AC 250 V; DC 50 V 3 AC 250 V	0.1...16 A 1- and 2- pole 0.1...12 A 3-pole

All dimensions without tolerances are for reference only. In the interest of improved design, performance and cost effectiveness the right to make changes in these specifications without notice is reserved. Product markings may not be exactly as the ordering codes. Errors and omissions excepted.

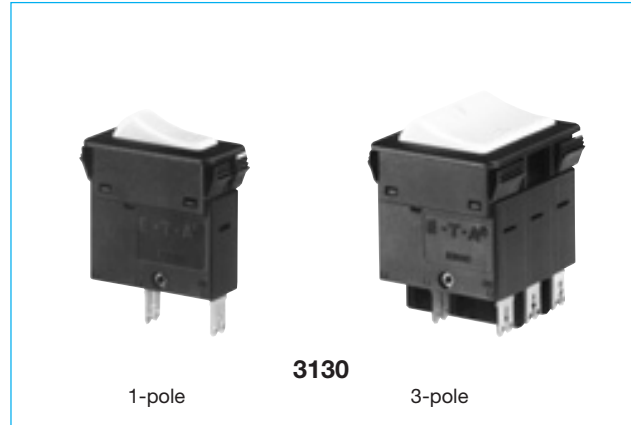

1-pole

3130

3-pole

## Technical data

For further details please see chapter: Technical Information

Voltage rating	AC 240 V; 3 AC 415 V; DC 50 V (UL: AC 250 V; 3 AC 250 V; DC 50 V)		
Current ratings	0.1...20 A	1-pole	
	0.1...16 A	2- and 3-pole	
Typical life	<b>1-pole</b>		
AC 240 V:	0.1...20 A	30,000 operations at $1 \times I_N$ , inductive	
DC 50 V:	0.1...4 A	30,000 operations at $1 \times I_N$ , inductive	
	4.5...16 A	30,000 operations at $1 \times I_N$ , resistive	
DC 28 V:	4.5...20 A	30,000 operations at $1 \times I_N$ , inductive	
	<b>2-pole</b>		
AC 240 V:	0.1...16 A	50,000 operations at $1 \times I_N$ , inductive	
DC 50 V:	0.1...16 A	50,000 operations at $1 \times I_N$ , inductive	
	<b>3-pole</b>		
3 AC 415 V:	0.1...16 A	30,000 operations at $1 \times I_N$ , inductive	
Ambient temperature	-30...+60 °C (-22...+140 °F)		
Insulation co-ordination (IEC 60664 and 60664 A)	rated impulse withstand voltage	pollution degree	
	2.5 kV	2	
	reinforced insulation in operating area		
Dielectric strength (IEC 60664 and 60664A)	test voltage		
operating area	AC 3,000 V		
current path/current path	AC 1,500 V		
Insulation resistance	> 100 M $\Omega$ (DC 500 V)		
Interrupting capacity $I_{cn}$	0.1...2 A	10 x $I_N$	
	2.5...20 A	150 A	1-pole
	2.5...16 A	250 A	2-pole
	2.5...12 A	150 A	3-pole
	14 + 16 A	130 A	3-pole
Interrupting capacity (UL 1077)	$I_N$	0.1...12 A	14...16 A
	1- + 2-pole	AC 250V/3500A	AC 250V/3500A
	3-pole	3AC 250V/5000A	
	1- + 2-pole	DC 50V/2000A	DC 50V/2000A
Degree of protection (IEC 60529/DIN 40050)	operating area IP40 terminal area IP00		
Vibration	5 g (57-500 Hz) $\pm$ 0.38 mm (10-57 Hz) to IEC 60068-2-6, test Fc 10 frequency cycles/axis		
Shock	1-pole: 25 g (11 ms) 2 + 3-pole: 20 g (11 ms) to IEC 60068-2-27, test Ea		
Corrosion	96 hours at 5 % salt mist, to IEC 60068-2-11, test Ka		
Humidity	240 hours at 95 % RH, to IEC 60068-2-3, test Ca		
Mass	approx. 45 g (three pole) approx. 31 g (double pole) approx. 17 g (single pole)		

1

## Ordering information - 1-pole

Type No.	3130	rocker switch/circuit breaker
Mounting	F	snap in frame
Frame	1	standard
	3	special single pole version
Number of poles	1	single pole, thermally protected
	A	1-pole, unprotected**
Frame mounting	0	panel thickness 1-2.5 mm (.039-.099 in) (only 3130-F1...-...)
	1	panel thickness 1.5-3.2 mm (.059-.126 in)(only 3130-F3.1...-...)
Terminal design	P7	blade terminals DIN 46244-C-Ms-S (QC 2x.110)
	H7	for terminals 1.1, 2.1 3.1 terminal screws M 3.5 for terminals 1.2, 2.2, 3.1 blade terminals (QC 2x.110)
	N7	blade terminals (QC 2x.110), with shunt terminal
Characteristic curve	T1	thermal, 1.05-1.4 I <sub>N</sub>
	Q1	switch, only with terminal design -N7
Switch style	W	rocker
	U	momentary switch function
Switch colour designation	opaque	translucent
	01	black 12 white
	02	white 14 red
	04	red 19 green
	09	green 29 black, rocker with green dot
Rocker markings	A	dot (ON position, only with switch colour designation 29)
	Q	"I" and "O" moulded in
Rocker illumination (optional)	12 Q Y	white rocker, yellow LED, AC/DC
	14 Q R	red rocker, red LED, AC/DC
	19 Q Y	green rocker, yellow LED, AC/DC
	29 A G	black rocker with dot, green LED
Illumination voltage range* (optional)	1	4 - 7 V (G,R,Y)
	2	10 - 14 V (G,R,Y)
	3	20 - 28 V (G,R,Y)
	4	42 - 54 V (R,Y)
	6	90 - 140 V (R,Y)
	7	185 - 275 V (R,Y)
	X	LED, DC 8 - 10 mA ***
Current ratings	0.1...20 A	
ordering example	3130 - F 1 1 0 - P7 T1 - W 12 Q Y 7 - 5 A	

\* N/A for non-illuminated version  
 \*\* unprotected poles have to ordered with terminal design N7  
 \*\*\* without series resistor and diode, to be selected by customer.  
 Recommendation:  
 4-7 V Rv 0.43 kΩ  
 10-14 V Rv 1.1 kΩ  
 20-28 V RV 2.7 kΩ  
 diode 1N4007

## Ordering information - multipole

Type No.	3130	rocker switch/circuit breaker multipole
Mounting	F	snap in frame
Frame	1	standard
Number of poles	2	2-pole, thermally protected
	3	3-pole, thermally protected
	5	2-pole, thermally protected on one pole only
	6	3-pole, thermally protected on two poles only
	B	2-pole, unprotected**
	C	3-pole, unprotected**
Frame mounting	0	panel thickness 1-2.5 mm (.039-.099 in) (only 3130-F1...-...)
Terminal design	P7	blade terminals DIN 46244-C-Ms-S (QC 2x.110)
	H7	for terminals 1.1, 2.1 3.1 terminal screws M 3.5; for terminals 1.2, 2.2, 3.1 blade terminals (QC 2x.110)
	N7	blade terminals DIN 46244-C-Ms-S (QC 2x.110), with shunt terminal
Characteristic curve	T1	thermal, 1.05-1.4 I <sub>N</sub>
	Q1	switch, only with terminal design -N7
Switch style	W	rocker
	U	momentary switch function
Switch colour designation	opaque	translucent
	01	black 12 white
	02	white 14 red
	04	red 19 green
	09	green
Rocker markings	Q	"I" and "O" moulded in
Rocker illumination (optional)	B	filament (≤ AC/DC 48 V), neon (≥ AC 115 V)
	G	green LED, DC
	R	red LED, DC
	Y	yellow LED, DC
Illumination voltage range* (optional)	1	4 - 7 V (B,G,R,Y)
	2	10 - 14 V (B,G,R,Y)
	3	20 - 28 V (B,G,R,Y)
	4	42 - 54 V (B,R,Y)
	6	90 - 140 V (B)
	7	185 - 275 V (B)
	8	320 - 450 V (B)
Current ratings	0.1...16 A	
ordering example	3130 - F 1 3 0 - P7 T1 - W 12 Q B 7 - 5 A	

\* N/A for non-illuminated version  
 \*\* unprotected poles have to ordered with terminal design N7



## Dimensions

### 3130-F110-...

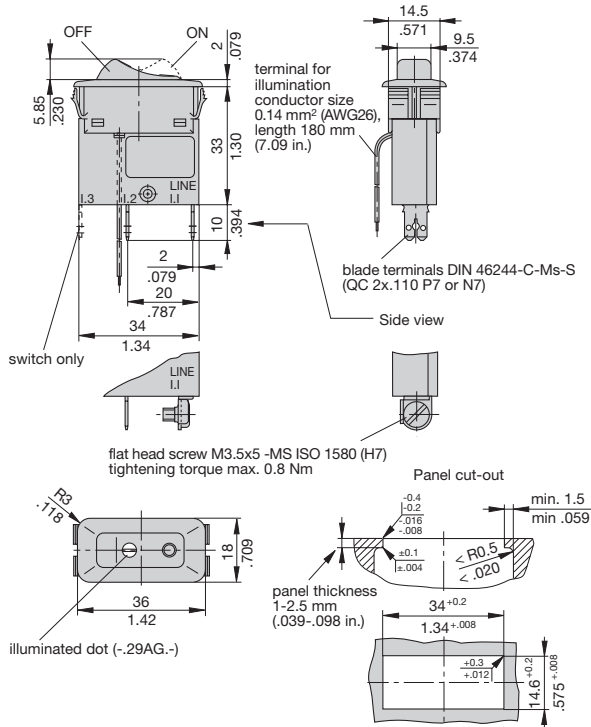

### 3130-F120-...

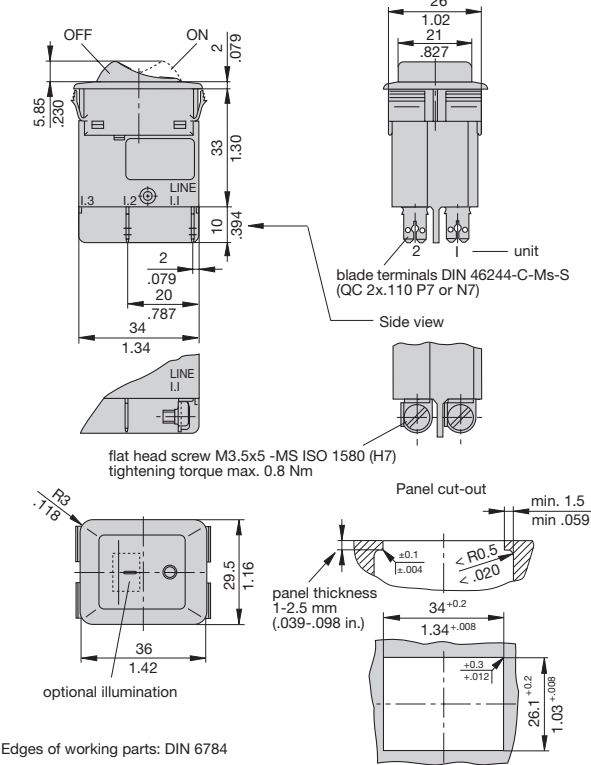

### 3130-F130-...

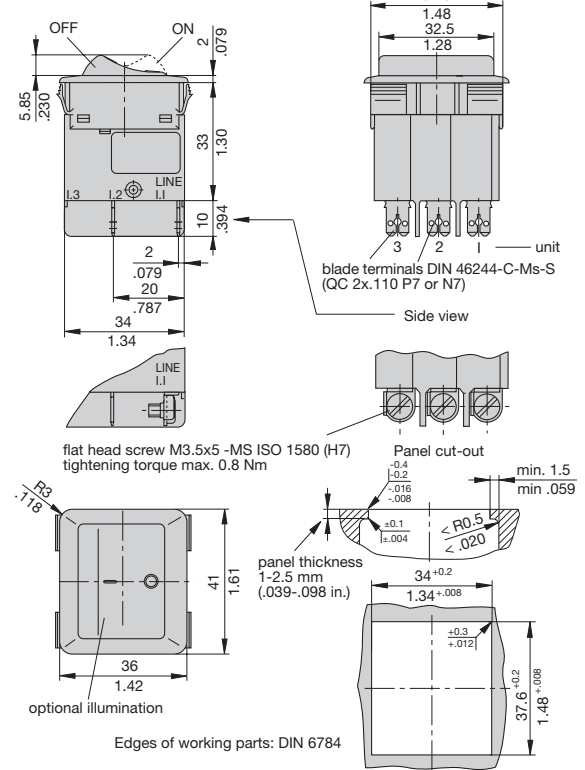

### 3130-F311-...

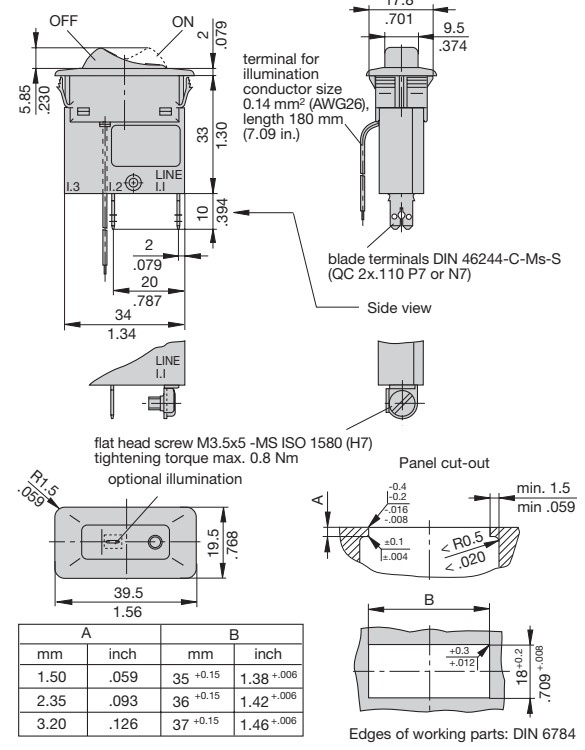

This is a metric design and millimeter dimensions take precedence ( $\frac{mm}{inch}$ )