

2.5V and 4.096V Voltage References

Features

- Precision Voltage Reference
- Output Voltages: 2.5V and 4.096V
- Initial Accuracy: $\pm 1\%$ (max.)
- Temperature Drift: ± 50 ppm/ $^{\circ}\text{C}$ (max.)
- Output Current Drive: ± 2 mA
- Maximum Input Current: 100 μA @ +25 $^{\circ}\text{C}$ (max.)
- Packages: TO-92 and SOT-23-3
- Industrial Temperature Range: -40 $^{\circ}\text{C}$ to +85 $^{\circ}\text{C}$

Applications

- Battery-powered Systems
- Handheld Instruments
- Instrumentation and Process Control
- Test Equipment
- Data Acquisition Systems
- Communications Equipment
- Medical Equipment
- Precision Power supplies
- 8-bit, 10-bit, 12-bit A/D Converters (ADCs)
- D/A Converters (DACs)

Typical Application Circuit

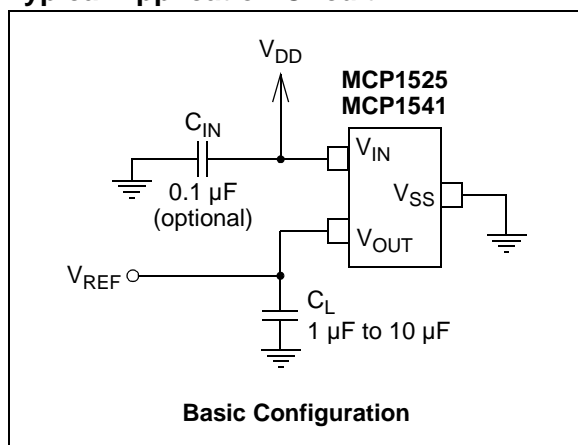

Description

The Microchip Technology Inc. MCP1525/41 devices are 2.5V and 4.096V precision voltage references that use a combination of an advanced CMOS circuit design and EPROM trimming to provide an initial tolerance of $\pm 1\%$ (max.) and temperature stability of ± 50 ppm/ $^{\circ}\text{C}$ (max.). In addition to a low quiescent current of 100 μA (max.) at 25 $^{\circ}\text{C}$, these devices offer a clear advantage over the traditional Zener techniques in terms of stability across time and temperature. The output voltage is 2.5V for the MCP1525 and 4.096V for the MCP1541. These devices are offered in SOT-23-3 and TO-92 packages, and are specified over the industrial temperature range of -40 $^{\circ}\text{C}$ to +85 $^{\circ}\text{C}$.

Temperature Drift

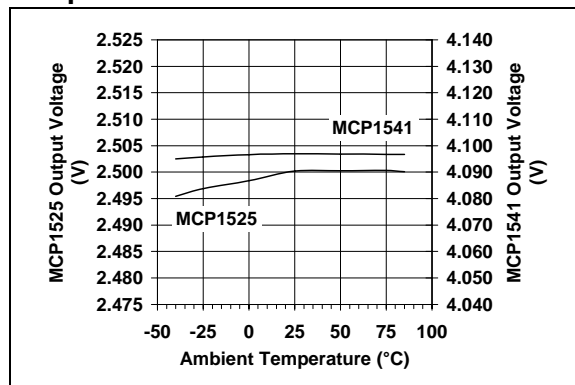

Package Types

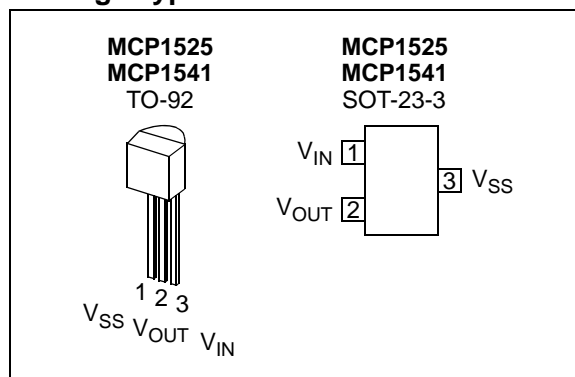

MCP1525/41

1.0 ELECTRICAL CHARACTERISTICS

Absolute Maximum Ratings †

$V_{IN} - V_{SS}$	7.0V
Input Current (V_{IN})	20 mA
Output Current (V_{OUT})	±20 mA
Continuous Power Dissipation ($T_A = 125^\circ\text{C}$).....	140 mW
All Inputs and Outputs	$V_{SS} - 0.6\text{V}$ to $V_{IN} + 1.0\text{V}$
Storage Temperature.....	-65°C to $+150^\circ\text{C}$
Maximum Junction Temperature (T_J).....	$+125^\circ\text{C}$
ESD protection on all pins (HBM)	≥ 4 kV

† **Notice:** Stresses above those listed under “Absolute Maximum Ratings” may cause permanent damage to the device. This is a stress rating only and functional operation of the device at those or any other conditions above those indicated in the operational listings of this specification is not implied. Exposure to maximum rating conditions for extended periods may affect device reliability.

DC ELECTRICAL SPECIFICATIONS

Electrical Characteristics: Unless otherwise indicated, $T_A = +25^\circ\text{C}$, $V_{IN} = 5.0\text{V}$, $V_{SS} = \text{GND}$, $I_{OUT} = 0\text{ mA}$ and $C_L = 1\ \mu\text{F}$.						
Parameter	Sym	Min	Typ	Max	Units	Conditions
Output						
Output Voltage, MCP1525	V_{OUT}	2.475	2.5	2.525	V	$2.7\text{V} \leq V_{IN} \leq 5.5\text{V}$
Output Voltage, MCP1541	V_{OUT}	4.055	4.096	4.137	V	$4.3\text{V} \leq V_{IN} \leq 5.5\text{V}$
Output Voltage Drift	TCV_{OUT}	—	27	50	ppm/ $^\circ\text{C}$	$T_A = -40^\circ\text{C}$ to 85°C (Note 1)
Long-Term Output Stability	V_{OUT}	—	2	—	ppm/hr	Exposed 1008 hrs @ $+125^\circ\text{C}$ (see Figure 1-1), measured @ $+25^\circ\text{C}$
Load Regulation	$\Delta V_{OUT}/\Delta I_{OUT}$	—	0.5	1	mV/mA	$I_{OUT} = 0\text{ mA}$ to -2 mA
	$\Delta V_{OUT}/\Delta I_{OUT}$	—	0.6	1	mV/mA	$I_{OUT} = 0\text{ mA}$ to 2 mA
	$\Delta V_{OUT}/\Delta I_{OUT}$	—	—	1.3	mV/mA	$I_{OUT} = 0\text{ mA}$ to -2 mA , $T_A = -40^\circ\text{C}$ to 85°C
	$\Delta V_{OUT}/\Delta I_{OUT}$	—	—	1.3	mV/mA	$I_{OUT} = 0\text{ mA}$ to 2 mA , $T_A = -40^\circ\text{C}$ to 85°C
Output Voltage Hysteresis	V_{HYS}	—	115	—	ppm	Note 2
Maximum Load Current	I_{SC}	—	±8	—	mA	$T_A = -40^\circ\text{C}$ to 85°C , $V_{IN} = 5.5\text{V}$
Input-to-Output						
Dropout Voltage	V_{DROP}	—	137	—	mV	$I_{OUT} = 2\text{ mA}$
Line Regulation	$\Delta V_{OUT}/\Delta V_{IN}$	—	107	300	$\mu\text{V}/\text{V}$	$V_{IN} = 2.7\text{V}$ to 5.5V for MCP1525 , $V_{IN} = 4.3\text{V}$ to 5.5V for MCP1541
	$\Delta V_{OUT}/\Delta V_{IN}$	—	—	350	$\mu\text{V}/\text{V}$	$V_{IN} = 2.7\text{V}$ to 5.5V for MCP1525 , $V_{IN} = 4.3\text{V}$ to 5.5V for MCP1541 , $T_A = -40^\circ\text{C}$ to 85°C
Input						
Input Voltage, MCP1525	V_{IN}	2.7	—	5.5	V	$T_A = -40^\circ\text{C}$ to 85°C
Input Voltage, MCP1541	V_{IN}	4.3	—	5.5	V	$T_A = -40^\circ\text{C}$ to 85°C
Input Current	I_{IN}	—	86	100	μA	No load
	I_{IN}	—	95	120	μA	No load, $T_A = -40^\circ\text{C}$ to 85°C

Note 1: Output temperature coefficient is measured using a “box” method, where the $+25^\circ\text{C}$ output voltage is trimmed as close to typical as possible. The 85°C output voltage is then again trimmed to zero out the tempco.

Note 2: Output Voltage Hysteresis is defined as the change in output voltage measured at $+25^\circ\text{C}$ before and after cycling the temperature to $+85^\circ\text{C}$ and -40°C ; refer to **Section 1.1.10 “Output Voltage Hysteresis”**.

AC ELECTRICAL SPECIFICATIONS

Electrical Characteristics: Unless otherwise indicated, $T_A = +25^\circ\text{C}$, $V_{IN} = 5.0\text{V}$, $V_{SS} = \text{GND}$, $I_{OUT} = 0\text{ mA}$ and $C_L = 1\text{ }\mu\text{F}$.						
Parameter	Sym	Min	Typ	Max	Units	Conditions
AC Response						
Bandwidth	BW	—	100	—	kHz	
Input and Load Capacitors (see Figure 4-1)						
Input Capacitor	C_{IN}	—	0.1	—	μF	Notes 1
Load Capacitor	C_L	1	—	10	μF	Notes 2
Noise						
MCP1525 Output Noise Voltage	E_{no}	—	90	—	$\mu\text{V}_{\text{P-P}}$	0.1 Hz to 10 Hz
	E_{no}	—	500	—	$\mu\text{V}_{\text{P-P}}$	10 Hz to 10 kHz
MCP1541 Output Noise Voltage	E_{no}	—	145	—	$\mu\text{V}_{\text{P-P}}$	0.1 Hz to 10 Hz
	E_{no}	—	700	—	$\mu\text{V}_{\text{P-P}}$	10 Hz to 10 kHz

Note 1: The input capacitor is optional; Microchip recommends using a ceramic capacitor.

Note 2: These parts are tested at both 1 μF and 10 μF to ensure proper operation over this range of load capacitors. A wider range of load capacitor values has been characterized successfully, but is not tested in production.

TEMPERATURE SPECIFICATIONS

Electrical Characteristics: Unless otherwise indicated, $T_A = +25^\circ\text{C}$, $V_{IN} = 5.0\text{V}$ and $V_{SS} = \text{GND}$.						
Parameter	Sym	Min	Typ	Max	Units	Conditions
Temperature Ranges						
Specified Temperature Range	T_A	-40	—	+85	$^\circ\text{C}$	
Operating Temperature Range	T_A	-40	—	+125	$^\circ\text{C}$	Note 1
Storage Temperature Range	T_A	-65	—	+150	$^\circ\text{C}$	
Thermal Package Resistances						
Thermal Resistance, TO-92	θ_{JA}	—	132	—	$^\circ\text{C}/\text{W}$	
Thermal Resistance, SOT-23-3	θ_{JA}	—	336	—	$^\circ\text{C}/\text{W}$	

Note 1: These voltage references operate over the Operating Temperature Range, but with reduced performance. In any case, the internal Junction Temperature (T_J) must not exceed the Absolute Maximum specification of $+150^\circ\text{C}$.

1.1 Specification Descriptions and Test Circuits

1.1.1 OUTPUT VOLTAGE

Output voltage is the reference voltage that is available on the output pin (V_{OUT}).

1.1.2 INPUT VOLTAGE

The input (operating) voltage is the range of voltage that can be applied to the V_{IN} pin and still have the device produce the designated output voltage on the V_{OUT} pin.

1.1.3 OUTPUT VOLTAGE DRIFT (TCV_{OUT})

The output temperature coefficient or voltage drift is a measure of how much the output voltage (V_{OUT}) will vary from its initial value with changes in ambient temperature. The value specified in the electrical specifications is measured and equal to:

EQUATION 1-1:

$$TCV_{OUT} = \frac{\Delta V_{OUT}/V_{NOM}}{\Delta T_A} \quad (\text{ppm}/^\circ\text{C})$$

Where:

$$V_{NOM} = 2.5\text{V, MCP1525}$$

$$V_{NOM} = 4.096\text{V, MCP1541}$$

MCP1525/41

3-Lead Plastic Transistor Outline (TO) (TO-92)

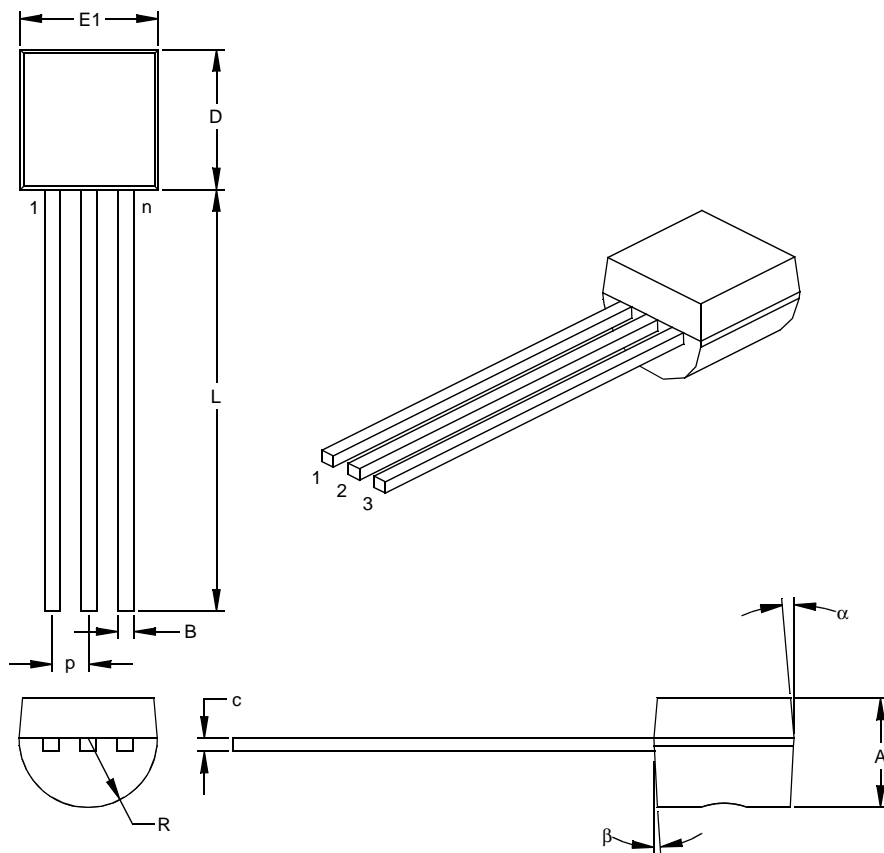

Dimension Limits	Units	INCHES*			MILLIMETERS		
		MIN	NOM	MAX	MIN	NOM	MAX
Number of Pins	n		3			3	
Pitch	p		.050			1.27	
Bottom to Package Flat	A	.130	.143	.155	3.30	3.62	3.94
Overall Width	E1	.175	.186	.195	4.45	4.71	4.95
Overall Length	D	.170	.183	.195	4.32	4.64	4.95
Molded Package Radius	R	.085	.090	.095	2.16	2.29	2.41
Tip to Seating Plane	L	.500	.555	.610	12.70	14.10	15.49
Lead Thickness	c	.014	.017	.020	0.36	0.43	0.51
Lead Width	B	.016	.019	.022	0.41	0.48	0.56
Mold Draft Angle Top	α	4	5	6	4	5	6
Mold Draft Angle Bottom	β	2	3	4	2	3	4

*Controlling Parameter

Notes:

Dimensions D and E1 do not include mold flash or protrusions. Mold flash or protrusions shall not exceed

.010" (0.254mm) per side.

JEDEC Equivalent: TO-92

Drawing No. C04-101

3-Lead Plastic Small Outline Transistor (TT) (SOT23)

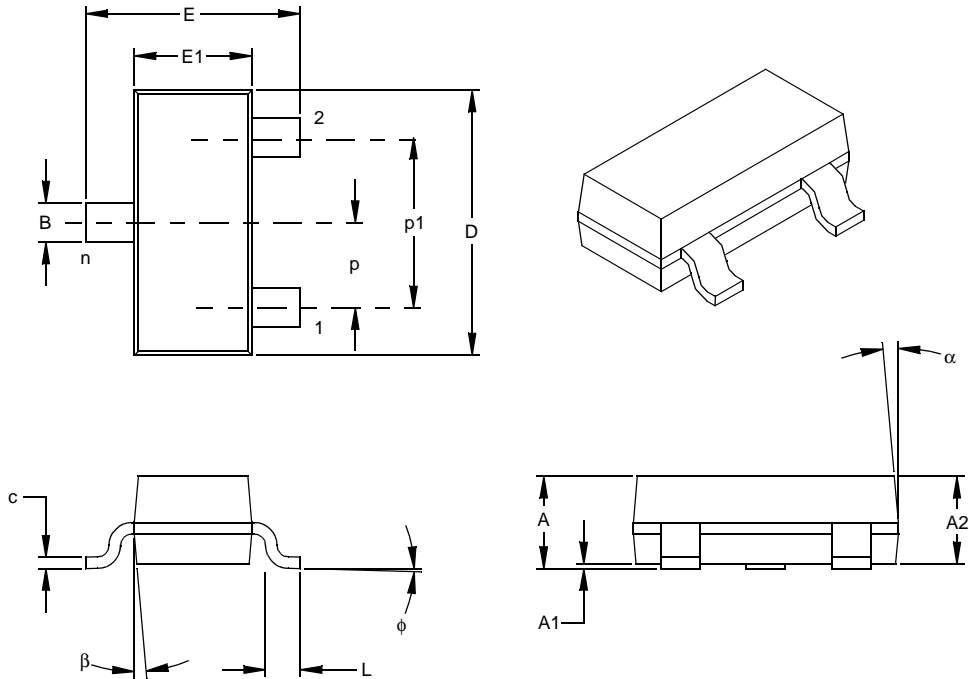

Units		INCHES*			MILLIMETERS		
Dimension Limits		MIN	NOM	MAX	MIN	NOM	MAX
Number of Pins	n		3			3	
Pitch	p		.038			0.96	
Outside lead pitch (basic)	p1		.076			1.92	
Overall Height	A	.035	.040	.044	0.89	1.01	1.12
Molded Package Thickness	A2	.035	.037	.040	0.88	0.95	1.02
Standoff §	A1	.000	.002	.004	0.01	0.06	0.10
Overall Width	E	.083	.093	.104	2.10	2.37	2.64
Molded Package Width	E1	.047	.051	.055	1.20	1.30	1.40
Overall Length	D	.110	.115	.120	2.80	2.92	3.04
Foot Length	L	.014	.018	.022	0.35	0.45	0.55
Foot Angle	φ	0	5	10	0	5	10
Lead Thickness	c	.004	.006	.007	0.09	0.14	0.18
Lead Width	B	.015	.017	.020	0.37	0.44	0.51
Mold Draft Angle Top	α	0	5	10	0	5	10
Mold Draft Angle Bottom	β	0	5	10	0	5	10

* Controlling Parameter
 § Significant Characteristic

Notes:

Dimensions D and E1 do not include mold flash or protrusions. Mold flash or protrusions shall not exceed .010" (0.254mm) per side.

JEDEC Equivalent: TO-236

Drawing No. C04-104

PRODUCT IDENTIFICATION SYSTEM

To order or obtain information, e.g., on pricing or delivery, refer to the factory or the listed sales office.

<u>PART NO.</u>	<u>X</u>	<u>/XX</u>
Device	Temperature Range	Package
Device	MCP1525: = 2.5V Voltage Reference MCP1541: = 4.096 Voltage Reference	
Temperature Range	I = -40°C to +85°C	
Package	TO = TO-92, Plastic Transistor Outline, 3-Lead TT = SOT23, Plastic Small Outline Transistor, 3-Lead	

Examples:

- a) MCP1525T-I/TT: Tape and Reel, Industrial Temperature, SOT23 package.
- b) MCP1525-I/TO: Industrial Temperature, TO-92 package.
- c) MCP1541T-I/TT: Tape and Reel, Industrial Temperature, SOT23 package.
- d) MCP1541-I/TO: Industrial Temperature, TO-92 package.