



crydom®



[home](#)
 [products](#)
 [sales](#)
 [support](#)
 [contact us](#)
 [about us](#)

Solid State Relays - Panel Mount: HA/HD60



Features

SCR output • 25-125Amp • 48-660 Vrms • AC Switching • AC/DC control • Snubberless • 1200 Vpk reverse voltage capability.

Product	INPUT SPECIFICATIONS	OUTPUT SPECIFICATIONS			
	Control Voltage Range	Load Current	Switching Voltage Type	Turn On	Load Voltage Range
HD60125	3-32 Volts DC	0.15-125 Amps RMS	AC	Zero cross	48-660 Volts RMS
HD60125-10	3-32 Volts DC	0.15-125 Amps RMS	AC	Random	48-660 Volts RMS
HD6025	3-32 Volts DC	0.04-25 Amps RMS	AC	Zero cross	48-660 Volts RMS
HD6025-10	3-32 Volts DC	0.04-25 Amps RMS	AC	Random	48-660 Volts RMS
HD6050	3-32 Volts DC	0.04-50 Amps RMS	AC	Zero cross	48-660 Volts RMS
HD6050-10	3-32 Volts DC	0.04-50 Amps RMS	AC	Random	48-660 Volts RMS
HD6090	3-32 Volts DC	0.04-90 Amps RMS	AC	Zero cross	48-660 Volts RMS

HD6090-10	3-32 Volts DC	0.04-90 Amps RMS	AC	Random	48-660 Volts RMS
HA60125	90-280 Volts RMS	0.15-125 Amps RMS	AC	Zero cross	48-660 Volts RMS
HA60125-10	90-280 Volts RMS	0.15-125 Amps RMS	AC	Random	48-660 Volts RMS
HA60125E	18-36 Volts RMS	0.15-125 Amps RMS	AC	Zero cross	48-660 Volts RMS
HA60125E-10	18-36 Volts RMS	0.15-125 Amps RMS	AC	Random	48-660 Volts RMS
HA6025	90-280 Volts RMS	0.04-25 Amps RMS	AC	Zero cross	48-660 Volts RMS
HA6025-10	90-280 Volts RMS	0.04-25 Amps RMS	AC	Random	48-660 Volts RMS
HA6025E	18-36 Volts RMS	0.04-25 Amps RMS	AC	Zero cross	48-660 Volts RMS
HA6025E-10	18-36 Volts RMS	0.04-25 Amps RMS	AC	Random	48-660 Volts RMS
HA6050	90-280 Volts RMS	0.04-50 Amps RMS	AC	Zero cross	48-660 Volts RMS
HA6050-10	90-280 Volts RMS	0.04-50 Amps RMS	AC	Random	48-660 Volts RMS
HA6050E	18-36 Volts RMS	0.04-50 Amps RMS	AC	Zero cross	48-660 Volts RMS
HA6050E-10	18-36 Volts RMS	0.04-50 Amps RMS	AC	Random	48-660 Volts RMS
HA6090	90-280 Volts RMS	0.04-90 Amps RMS	AC	Zero cross	48-660 Volts RMS
HA6090-10	90-280 Volts RMS	0.04-90 Amps RMS	AC	Random	48-660 Volts RMS
HA6090E	18-36 Volts RMS	0.04-90 Amps RMS	AC	Zero cross	48-660 Volts RMS
HA6090E-10	18-36 Volts RMS	0.04-90 Amps RMS	AC	Random	48-660 Volts RMS

- Zero Voltage and Random Turn-On Switching
- Panel Mount
- 1200V Blocking Capability
- 600Vac - the preferred choice in Canada
- Integrated Overvoltage Protection by Automatic Self Turn-On (Suffix P)

Featuring state-of-the-art Surface Mount Technology, these SPST-NO relays deliver proven reliability in the most demanding applications. Output consists of an SCR AC switch and is available in zero-cross, random turn-on (phase controllable) and versions with either AC or DC input (coil) control. Manufactured in Crydom's ISO 9001 Certified facility for optimum product performance and reliability.

MODEL NUMBERS	AC CONTROL	HA6025	HA6050	HA6090	HA60125
	DC CONTROL	HD6025	HD6050	HD6090	HD60125
OUTPUT SPECIFICATIONS ①					
Nominal Line Voltage (±10%) [Vrms]		600	600	600	600
Operating Voltage Range (47-63 Hz) [Vrms]		48-660	48-660	48-660	48-660
Max. Load Current ③ [Arms]		25	50	90	125
Min. Load Current, [mArms]		40	40	40	150
Transient Overvoltage [Vpk]		1200	1200	1200	1200
Max. Surge Current, (16.6ms) [Apk]		250	625	1,200	1,750
Max. On-State Voltage Drop @ Rated Current [Vpk]		1.7	1.7	1.7	1.7
Thermal Resistance Junction to Case (R _{θJC}) [° C/W]		1.02	0.63	0.28	0.22
Maximum I ² t for Fusing, (8.3 msec.) [A ² sec]		260	1,620	6,000	12,700
Max. Off-State Leakage Current @ Rated Voltage [mArms] ⑦		5	5	5	5
Min. Off-State dv/dt @ Max. Rated Voltage [V/μsec] ②		500	500	500	500
Max. Turn-On Time ⑤		1/2 Cycle (DC Input), 10.0 msec (AC Input)			
Max. Turn-Off Time		1/2 Cycle (DC Input), 40.0 msec (AC Input)			
Power Factor (Min.) with Max. Load		0.5	0.5	0.5	0.5

INPUT SPECIFICATIONS	DC CONTROL (D PREFIX)	AC CONTROL (A PREFIX) ④	AC CONTROL (E SUFFIX)
Control Voltage Range	3-32 Vdc	90-280 Vrms (60Hz)	18-36 Vrms
Max. Reverse Voltage	-32 Vdc	---	---
Max. Turn-On Voltage	3.0 Vdc	90 Vrms	18 Vrms
Min. Turn-Off Voltage	1.0 Vdc	10 Vrms	4.0 Vrms
Nominal Input Impedance	See Note ⑥	60K Ohms	9.0K Ohms
Typical Input Current	2.0 mA ⑥	2mA @ 120 Vrms, 4mA @ 240 Vrms	3mA @ 24 Vrms

GENERAL NOTES

- ① All parameters at 25°C unless otherwise specified.
- ② Off-State dv/dt test method per EIA/NARM standard RS-443, paragraph 13.11.1
- ③ Heat sinking required, for derating curves see page 2.
- ④ 24 Vac Input option, E suffix.
- ⑤ Turn-on time for random turn-on versions is 0.02 msec (DC Control Models).
- ⑥ Input circuitry incorporates active current limiter.
- ⑦ No internal snubber.

© 2007 CRYDOM Inc., Specifications subject to change without notice.

GENERAL SPECIFICATIONS

Dielectric Strength 50/60Hz Input/Output/Base	4000 Vrms
Insulation Resistance (Min.) @ 500 Vdc	10 ⁹ Ohm
Max. Capacitance Input/Output	8 pF
Ambient Operating Temperature Range	-40 to 80°C
Ambient Storage Temperature Range	-40 to 125°C

MECHANICAL SPECIFICATIONS

Weight: (typical)	3.0 oz. (86.5g)
Encapsulation:	Thermally Conductive Epoxy
Terminals:	Screws and Saddle Clamps Furnished, Unmounted

AVAILABLE OPTIONS

- E** 24 VAC Input (18-36 Vac)
Example: **HA6025E**
- F** Faston Terminals (Up to 50 Amp Models)
Example: **HD6050F**
- G** Input Status LED.
Agencies Approval Pending
Example: **HD6050G**
Note: Control Voltage Range 4.5-32Vdc for DC Control Models.
- P** Internal Overvoltage Protection.
Relay Will Self Trigger Between 900-1200 Vpk. Not Suitable For Capacitive Loads.
Agencies Approval Pending.
Example: **HD6025P**
- 10** Random Turn-On (AC & DC Control)
Phase Controllable (DC Control)
Example: **HD6090-10**
- H** Heat Transfer Pad (Attached)
Example: **HD6090H**

Ordering System: Combination of the suffixes should be made in the following order:
EFPG-10.
Example: **HA6050EFPG-10**

Crydom Heat Sinks offer excellent thermal management and are perfectly matched to the load current ratings of Crydom panel mount relays. Request Crydom's Heat Sink specification sheet for all the details.

Screw Torque Requirements:
6-32 Screws - 10 in./lbs.,
8-32 and 10-32 Screws - 20in./lbs.
(Screws dry without grease.)

Fastons:
Single pair (up to 25A)
Double pair* (up to 50A).
*Caution: User must connect to both pairs

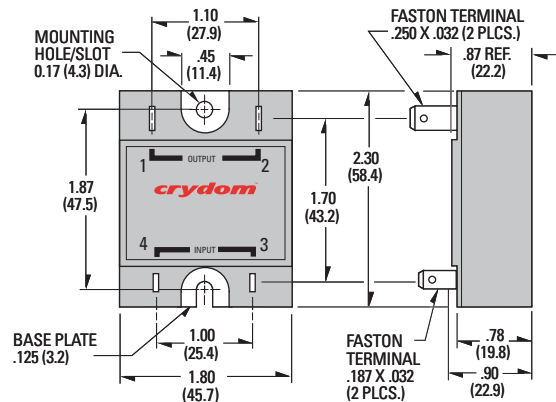
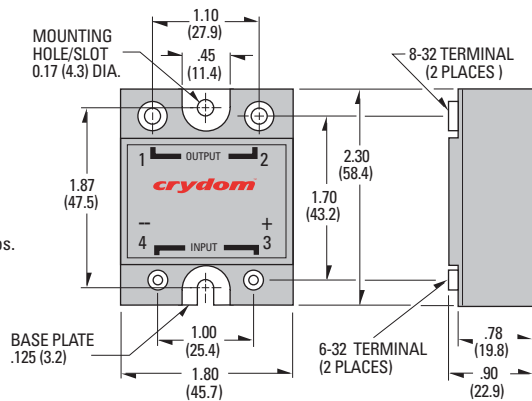

All dimensions are in inches (millimeters)

APPROVALS

UL E116950
CSA LR81689
VDE 10143 UG



© 2007 CRYDOM Inc., Specifications subject to change without notice.

