

Plug-in Screw Connector System for Printed Circuit Boards

TYPE 971-SLK /-SLS /-SLW

5 mm spacing - 2 to 64 poles



Series	Download PDF	3D Model	Can plug with	How to order	Color specifications	Print
--------	--------------	----------	---------------	--------------	----------------------	-------



971-SLK, 971-SLS, 971-SLW



One possible variation of assembly



RoHS WEEE Pb free compliant

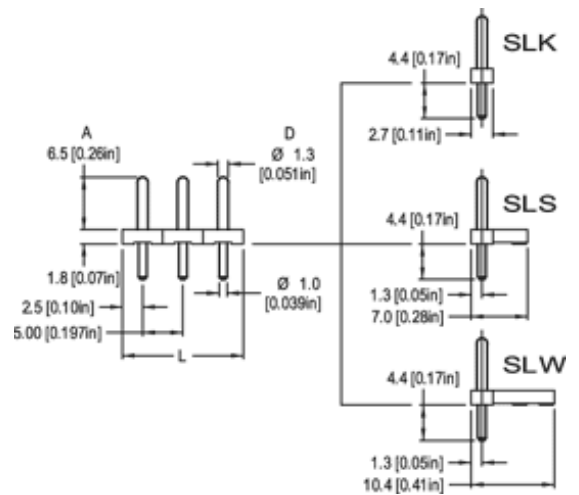

Dimensions: mm (in.)

Length of Pinstrip (L)

$L = \text{No. of Poles} \times \text{Center to Center Spacing}$

Other options:

In Ø1.10 mm diameter (D), the following protruding lengths (A) are available: 7.8, 10.3, 11.0, 11.7, 11.9, 12.5, 14.2, 14.7 and 15.7 mm.

In Ø1.15 mm diameter (D), the following protruding lengths (A) are available: 6.5 and 14.7 mm.

In Ø1.30 mm diameter (D), the following protruding lengths (A) are available: 6.5, 7.2, 7.7, 7.8, 8.5, 10.5, 11.0, 16.5, 19.8, 21.5, 22.0 and 29.0 mm.

When locating connector, allow 0.5 mm clearance around it for process-induced variations.

Description

- Pinstrip
- Plug-In Direction and Wire Entrance Perpendicular to PCB when plugged with **971-FBS (-DS)**
- Plug-In Direction Perpendicular to PCB and Wire Entrance Parallel to PCB when plugged with **950-FL-DS, 950-T-FL-DS, 950-NAF-DS, 950-GFL-DS, 950-NLFL-DS, 970-FBW (-DS), 115-F-111, 115-F-118 and 115-F-211**

Technical Data

Approval Information

UL File No.E69841
CSA File No.LR24322

Rating	Current(A)	Voltage(V)	Application group	AWG
UL	10	300	B	
CSA	10	300	B,D,E	

Material

Center to Center Spacing: 5 mm (0.197 in.)
Recommended Hole Diameter in PC Board:
1.3 mm (0.051 in.) for 1.0 mm (0.039 in.) pin
(standard) 1.4 mm (0.055 in.) for 1.1 mm (0.043 in.)
pin (limited options) 1.6 mm (0.063 in.) for 1.3 mm
(0.051 in.) pin (limited options)

Application

WECO offers a variety of pin lengths and pin diameters. In order to order these special pins, please refer to the special pin page found in the ordering box.

Molding: PBT GF (glass fiber reinforced), self extinguishing UL 94, V-0, color black

Temperature limits:

Short Time: 200°C (392°F)

Continuous: RTI 105°C (221°F)

Low Limit: -40°C (-40°F)

Comparative Tracking Index: CTI > 175

Oxygen Index Rating: 32%

Solder Pin: PCB end: Ø 1 mm (0.039 in.) or Ø1.1 (0,043 in.), plug-in end: Ø1.1 mm (0.043 in.), Ø 1.15 (0.045 in.) and Ø 1.3 mm (0.051 in.), Tin plated copper alloy

 [Top of page](#)

How to order

Item 971-SLK /-SLS /-SLW

Options

- G05: Gold Plating (5 micro inches)
- G30: Gold Plating (30 micro inches)
- S30: Silver Plating (30 micro inches)

Note: Plated component: solder pin

Ordering Note: To order alternate pin lengths and diameters please download the PDF file above. Version with 10 mm spacing (973-SLK /-SLS /-SLW).

971-SL	BASE WIDTH:	POLES:
	2.7 mm: K 7 mm: S 10.4 mm: W	02 to 64

[Request sample](#)

[Request quote](#)

Quantity

Accessories

[Add to shopping cart](#)

971-SLK, SLS, SLW STANDARD INSERTION FORCE THROUGH HOLE WAVE PCB PIN STRIPS WITH 1.3 MM PCB PINS

Often imitated. Never equaled. THESE PIN STRIPS HAVE A TYPICAL INSERTION FORCE OF 400 GRAMS (14 OZ.) PER POLE

HOW TO ORDER

- 1- CHOOSE THE TYPE OF STRIP SLK, SLS OR SLW AS PER DIAGRAM A
- 2- CHOOSE THE SHAPE OF PIN AS PER DIAGRAM B (D1, D2, D3, L2, L3)
- 3- CHOOSE THE LENGTH OF PIN AS PER TABLE 1 COLUMN L1
- 4- CHOOSE THE TYPE OF PLATING AS TABLE 2

5- FILLOUT THE ORDERING BOXES BELOW

OR CHOOSE A PREVIOUSLY DEVELOPED PRODUCT IN TABLE 3

Note: PIN STRIP MOLDING MATERIAL IS GF PBT OR PA UL94-V0

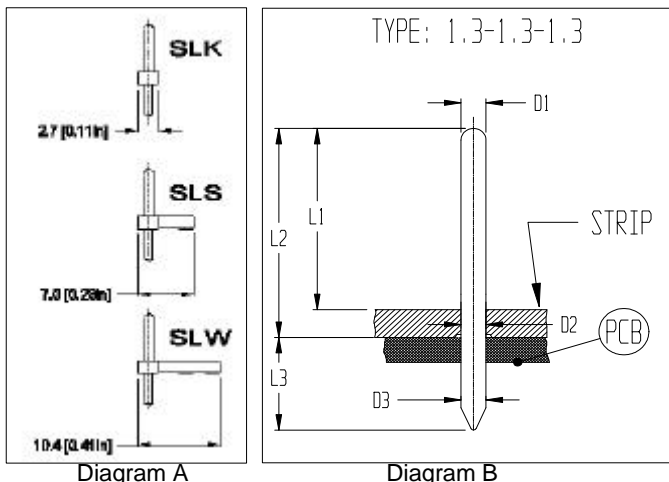

TABLE 1 PIN & STRIP CHOICES

APPLICATION STRIP / NO. OF POLES	BLANK PIN ITEM NUMBER	TIN PLATED PIN ITEM NUMBER	SHAPE	PIN DIAMETER PLUG END D1	PIN DIAMETER MIDDLE D2	PIN DIAMETER PCB END D3	PIN'S PLUG END VS STRIP L1	PIN'S PLUG END VS PCB L2	EFFECTIVE PCB PIN LENGTH L3
971-SLK, SLS, SLW/02 TO 24	50.477.532	10.477.532	SN5	1.3	1.3	1.3	7.8	9.6	4.4
TYPE OF STRIP	NO. OF POLES (02 TO 24)	PLATING	D1	D2	D3	L1	L2	L3	

TABLE 2 CHOOSE A PIN PLATING

TIN PLATING AT 5 MICROMETERS IS STANDARD FOR TIN PLATING LEAVE BLANK

FOR SILVER 5 MICROINCHES ADD -S05

FOR SILVER 12 MICROINCHES ADD -S12

FOR SILVER 30 MICROINCHES ADD -S30

FOR GOLD 5 MICROINCHES ADD -G05

FOR GOLD 12 MICROINCHES ADD -G12

FOR GOLD 30 MICROINCHES ADD -G30

TABLE 4 PIN APPLICATION GUIDELINES & SPECIFICATIONS

- SEE DIAGRAMS PIN FOR D1, D2, D3, L1, L2 & L3 EXPLANATIONS
- PCB PIN DIAMETER 1.3 MM AS PER TABLE 1, COLUMN D3
- RECOMMENDED PCB HOLE DIAMETER 1.6 MM FOR THIS 1.3 MM PIN
- RECOMMENDED PCB HOLE ALIGNMENT STAGGER 0.3 MM MAXIMUM FOR THIS PCB PIN AND PCB PIN HOLE COMBINATION OF 1.3 AND 1.6 MM.
- PCB PIN LENGTH 4 MM, TABLE 1 COLUMN L3, IT CAN BE ADJUSTED AT THE EXPENSE OF PLUG PIN
- PLUG PIN LENGTH ABOVE STRIP TABLE 1 COLUMN L1. IT CAN BE ADJUSTED AT THE EXPENSE OF PCB PIN
- PLUG PIN LENGTH ABOVE PCB TABLE 1 COLUMN L2, IMPORTANT FOR FIT CALCULATIONS

TABLE 3: PREVIOUSLY DEVELOPED PRODUCTS

APPLICATION STRIP	BLANK PIN ITEM NUMBER	PLATED PIN ITEM NUMBER	PLATING	PIN DIAMETER PLUG END D1	PIN DIAMETER MIDDLE D2	PIN DIAMETER PCB END D3	PIN'S PLUG END VS STRIP L1	PIN'S PLUG END VS PCB L2	EFFECTIVE PCB PIN LENGTH L3
971-SLK-1.3/08	50.477.532	10.477.532	SN5	1.3	1.3	1.3	7.8	9.6	4.4

971-SLK, SLS, SLW LOW INSERTION FORCE THROUGH HOLE WAVE PCB PIN STRIPS WITH 1.1 MM PCB PINS

Often imitated. Never equaled. THESE PIN STRIPS HAVE A TYPICAL INSERTION FORCE OF 125 GRAMS (4 OZ.) PER POLE

HOW TO ORDER

- 1- CHOOSE THE TYPE OF STRIP SLK, SLS OR SLW-1.1 AS PER DIAGRAM A
- 2- CHOOSE THE SHAPE OF PIN AS PER DIAGRAM B (D1, D2, D3, L2, L3)
- 3- CHOOSE THE LENGTH OF PIN AS PER TABLE 1 COLUMN L1
- 4- CHOOSE THE TYPE OF PLATING AS TABLE 2
- 5- FILLOUT THE ORDERING BOXES BELOW

OR CHOOSE A PREVIOUSLY DEVELOPED PRODUCT IN TABLE 3

Note: PIN STRIP MOLDING MATERIAL IS GF SPS UL94-V0

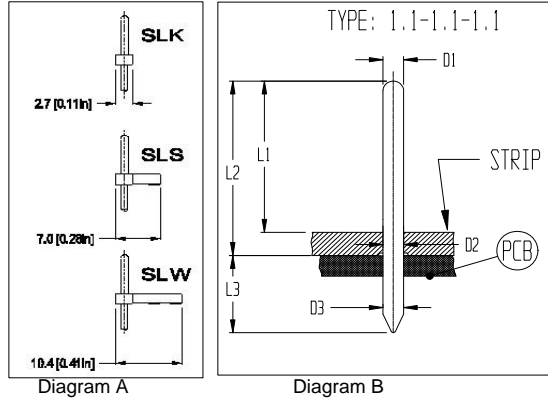

TABLE 1 PIN & STRIP CHOICES				PIN DIAMETER PLUG END	PIN DIAMETER MIDDLE	PIN DIAMETER PCB END	PIN'S PLUG END VS STRIP	PIN'S PLUG END VS PCB	EFFECTIVE PCB PIN LENGTH
APPLICATION STRIP	BLANK PIN ITEM NUMBER	TIN PLATED PIN ITEM NUMBER	SHAPE	D1	D2	D3	L1	L2	L3
971-SLK, SLS, SLW /02 TO 24-1.1-6.1	50.477.529	10.477.529	STANDARD	1.1	1.1	1.1	6.1	7.9	4.4
971-SLK, SLS, SLW /02 TO 24-1.1-11	PIN110-045	PIN110-047	LONG	1.1	1.1	1.1	11	12.8	4.4
971-SLK, SLS, SLW /02 TO 24-1.1-11.8	PIN971-006	PIN971-007	XLONG	1.1	1.1	1.1	11.8	13.6	4.4
971-SLK, SLS, SLW /02 TO 24-1.1-6.1-14	PIN971-008	PIN971-009	XXLONG	1.1	1.1	1.1	14	15.8	4.4
971-SLK, SLS, SLW /02 TO 24-1.1-6.1-14.7	PIN971-014	PIN971-015	XXXLONG	1.1	1.1	1.1	14.7	16.5	4.4
TYPE OF STRIP	NO. OF POLES (02 TO 24)		PLATING	D1	D2	D3	L1	L2	L3

TABLE 2 CHOOSE A PIN PLATING	TABLE 4 PIN APPLICATION GUIDELINES & SPECIFICATIONS
<p>TIN PLATING AT 5 MICROMETERS IS STANDARD FOR TIN PLATING LEAVE BLANK</p> <p>FOR SILVER 5 MICROINCHES ADD -S05</p> <p>FOR SILVER 12 MICROINCHES ADD -S12</p> <p>FOR SILVER 30 MICROINCHES ADD -S30</p> <p>FOR GOLD 5 MICROINCHES ADD -G05</p> <p>FOR GOLD 12 MICROINCHES ADD -G12</p> <p>FOR GOLD 30 MICROINCHES ADD -G30</p>	<p>- SEE DIAGRAMS PIN FOR D1, D2, D3, L1, L2 & L3 EXPLANATIONS</p> <p>- PCB PIN DIAMETER 1.1 MM AS PER TABLE 1, COLUMN D3</p> <p>- RECOMMENDED PCB HOLE DIAMETER 1.4 MM FOR THIS 1.1 MM PIN</p> <p>- RECOMMENDED PCB HOLE ALIGNMENT STAGGER 0.3 MM MAXIMUM FOR THIS PCB PIN AND PCB PIN HOLE COMBINATION OF 1.1 AND 1.4 MM.</p> <p>- PCB PIN LENGTH 4.4 MM, TABLE 1 COLUMN L3 , IT CAN BE ADJUSTED AT THE EXPENSE OF PLUG PIN</p> <p>- PLUG PIN LENGTH ABOVE STRIP TABLE 1 COLUMN L1. IT CAN BE ADJUSTED AT THE EXPENSE OF PCB PIN</p> <p>- PLUG PIN LENGTH ABOVE PCB TABLE 1 COLUMN L2, IMPORTANT FOR FIT CALCULATIONS</p>

TABLE 3: PREVIOUSLY DEVELOPED PRODUCTS				PIN DIAMETER PLUG END	PIN DIAMETER MIDDLE	PIN DIAMETER PCB END	PIN'S PLUG END VS STRIP	PIN'S PLUG END VS PCB	EFFECTIVE PCB PIN LENGTH
APPLICATION STRIP	BLANK PIN ITEM NUMBER	PLATED PIN ITEM NUMBER	PLATING	D1	D2	D3	L1	L2	L3
971-SLK/02-006	PIN971-006	PIN971-007	SN5	1.1	1.1	1.1	11.8	13.6	4.4
971-SLK/08-001	PIN971-006	PIN971-007	SN5	1.1	1.1	1.1	11.8	13.6	4.4
971-SLK/18-001	PIN971-006	PIN971-007	SN5	1.1	1.1	1.1	11.8	13.6	4.4
971-SLK/23-001	PIN971-006	PIN971-007	SN5	1.1	1.1	1.1	11.8	13.6	4.4
971-SLK/02-007	PIN971-008	PIN971-009	SN5	1.1	1.1	1.1	14	15.8	4.4
971-SLK/03-002	PIN971-014	PIN971-015	SN5	1.1	1.1	1.1	14.7	16.5	4.4
971-SLK/07-003	PIN971-014	PIN971-015	SN5	1.1	1.1	1.1	14.7	16.5	4.4
971-SLK/09-001	PIN971-014	PIN971-015	SN5	1.1	1.1	1.1	14.7	16.5	4.4
971-SLK/12-003	PIN971-014	PIN971-015	SN5	1.1	1.1	1.1	14.7	16.5	4.4
971-SLK/01-001	PIN971-014	PIN971-015	SN5	1.1	1.1	1.1	14.7	16.5	4.4
971-SLK/06-1.1	TBA	TBA	SN5	1.1	1.1	1.1	6.1	7.9	4.4
971-SLK/07-006	PIN110-045	PIN110-047	SN5	1.1	1.1	1.1	11	12.8	4.4
971-SLK/64-007	PIN110-045	PIN110-046	G05	1.1	1.1	1.1	11	12.8	4.4

971-SLK, SLS, SLW STANDARD

INSERTION FORCE THROUGH HOLE WAVE PCB PIN STRIPS WITH 1 MM STANDARD PCB PINS
THESE PIN STRIPS HAVE A TYPICAL INSERTION FORCE OF 400 GRAMS (14 OZ.) PER POLE

HOW TO ORDER

- 1- CHOOSE THE TYPE OF STRIP SLK, SLS OR SLW AS PER DIAGRAM A
- 2- CHOOSE THE SHAPE OF PIN AS PER DIAGRAM B (D1, D2, D3, L2, L3)
- 3- CHOOSE THE LENGTH OF PIN AS PER TABLE 1 COLUMN L1
- 4- CHOOSE THE TYPE OF PLATING AS TABLE 2
- 5- FILLOUT THE ORDERING BOXES BELOW

OR CHOOSE A PREVIOUSLY DEVELOPED PRODUCT IN TABLE 3

Note: PIN STRIP MOLDING MATERIAL IS GF PBT UL94-V0

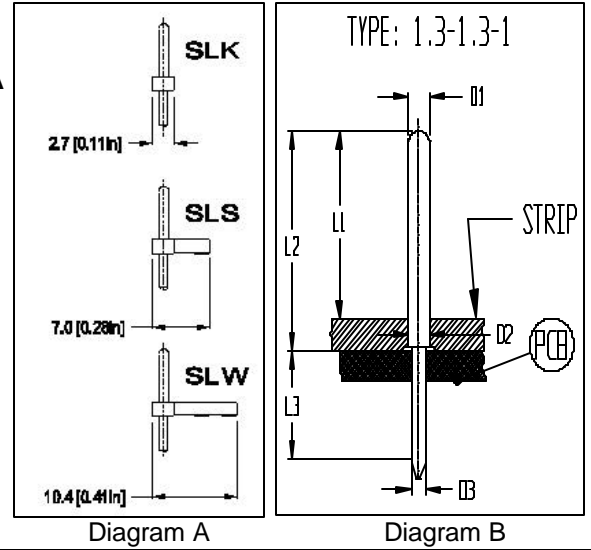

TABLE 1 PIN & STRIP CHOICES				PIN DIAMETER PLUG END	PIN DIAMETER MIDDLE	PIN DIAMETER PCB END	PIN'S PLUG END VS STRIP	PIN'S PLUG END VS PCB	EFFECTIVE PCB PIN LENGTH
APPLICATION STRIP	ITEM	PLATED	SHAPE	D1	D2	D3	L1	L2	L3
971-SLK, SLS or SLW/02 to 24	PIN970-011	PIN970-012	STANDARD	1,3	1,3	1	6,5	8,3	4,4
971-SLK, SLS or SLW/02 to 24-7.7	PIN971-055	PIN971-056	LONG				7,7	9,5	3,2
971-SLK, SLS or SLW/02 to 24-8.6	PIN971-046	PIN971-047	XLONG				8,6	10,4	4,4
971-SLK, SLS or SLW/02 to 24-10.5	50.477.516	PIN970-010	XXLONG				10,5	12,3	4,4
971-SLK, SLS or SLW/02 to 24-16.3	PIN970-013	PIN970-009	XXXLONG				16,3	18,1	4,6
971-SLK, SLS or SLW/02 to 24-19.8	PIN970-014	PIN970-020	4XLONG				19,8	21,6	4,4
971-SLK, SLS or SLW/02 to 24-21.3	PIN970-016	PIN970-015	5XLONG				21,3	23,1	4
971-SLK, SLS or SLW/02 to 24-29	PIN971-044	PIN971-045	6XLONG				29	30,8	3,5
SPECIAL APPLICATIONS ONLY	PIN970-018	PIN970-017	PIN				10,8	12,6	10,25
SPECIAL APPLICATIONS ONLY		10.477.527	PIN				8,5	10,3	10
SPECIAL APPLICATIONS ONLY	PIN970-020	PIN970-019	SHORT PCB				7	8,8	2

TYPE OF STRIP	NO. OF POLES (02 TO 24)	PLATING	D1	D2	D3	L1	L2	L3

TABLE 2 CHOOSE A PIN PLATING	TABLE 4 PIN APPLICATION GUIDELINES & SPECIFICATIONS
TIN PLATING AT 5 MICROMETERS IS STANDARD FOR TIN PLATING LEAVE BLANK	SEE DIAGRAMS PIN FOR D1, D2, D3, L1, L2 & L3 EXPLANATIONS
FOR SILVER 5 MICROINCHES ADD -S05	PCB PIN DIAMETER 1.0 MM AS PER TABLE 1, COLUMN D3
FOR SILVER 12 MICROINCHES ADD -S12	RECOMMENDED PCB HOLE DIAMETER 1.3 MM FOR THIS 1.0 MM PIN
FOR SILVER 30 MICROINCHES ADD -S30	RECOMMENDED PCB HOLE ALIGNMENT STAGGER 0.3 MM MAXIMUM FOR THIS PCB PIN
FOR GOLD 5 MICROINCHES ADD -G05	AND PCB PIN HOLE COMBINATION OF 1.0 AND 1.3 MM.
FOR GOLD 12 MICROINCHES ADD -G12	PCB PIN LENGTH 3.5 TO 4.4 MM, TABLE 1 COLUMN L3, EXCEPT FOR SPECIAL APPLICATIONS
FOR GOLD 30 MICROINCHES ADD -G30	PLUG PIN LENGTH ABOVE STRIP TABLE 1 COLUMN L1
	PLUG PIN LENGTH ABOVE PCB TABLE 1 COLUMN L2, IMPORTANT FOR FIT CALCULATIONS
	SPECIAL APPLICATIONS ONLY DISCUSS WITH FACTORY HAVE SHORT OR LONG L3

TABLE 3: PREVIOUSLY DEVELOPED PRODUCTS				DIAME	DIAME	DIAME	END VS	END VS PCB	PCB PIN
APPLICATION STRIP	ITEM	PIN ITEM	PLATING	D1	D2	D3	L1	L2	L3
971-SLK/02-19.8mm	PIN970-014	PIN970-020	SN5	1,3	1,3	1	19,8	21,6	4,4
971-SLK/03-001	PIN970-013	PIN970-009	SN5	1,3	1,3	1	16,3	18,1	4,6
971-SLK/05-19.8MM	PIN970-014	PIN970-020	SN5	1,3	1,3	1	19,8	21,6	4,4
971-SLK/06-005	PIN971-044	PIN971-045	SN5	1,3	1,3	1	29	30,8	3,5
971-SLK/64	PIN970-011	PIN970-012	SN5	1,3	1,3	1	6,5	8,3	4,4
971-SLK/64-19.8	PIN970-014	PIN970-020	SN5	1,3	1,3	1	19,8	21,6	4,4
971-SLS/09-002	PIN971-046	PIN971-047	SN5	1,3	1,3	1	8,6	10,4	4,4
971-SLW/64	PIN970-011	PIN970-012	SN5	1,3	1,3	1	6,5	8,3	4,4

971-SLK, SLS, SLW LOW INSERTION FORCE THROUGH HOLE WAVE PCB PIN STRIPS WITH 1 MM STANDARD PCB PINS.

Often imitated. Never equaled. THESE PIN STRIPS HAVE A TYPICAL INSERTION FORCE OF 125 GRAMS (4 OZ.) PER POLE

HOW TO ORDER

- 1- CHOOSE THE TYPE OF STRIP SLK, SLS OR SLW-1.3 AS PER DIAGRAM A
- 2- CHOOSE THE SHAPE OF PIN AS PER DIAGRAM B (D1, D2, D3, L2, L3)
- 3- CHOOSE THE LENGTH OF PIN AS PER TABLE 1 COLUMN L1
- 4- CHOOSE THE TYPE OF PLATING AS TABLE 2

5- FILLOUT THE ORDERING BOXES BELOW

OR CHOOSE A PREVIOUSLY DEVELOPED PRODUCT IN TABLE 3

Note: PIN STRIP MOLDING MATERIAL IS GF SPS UL94-V0

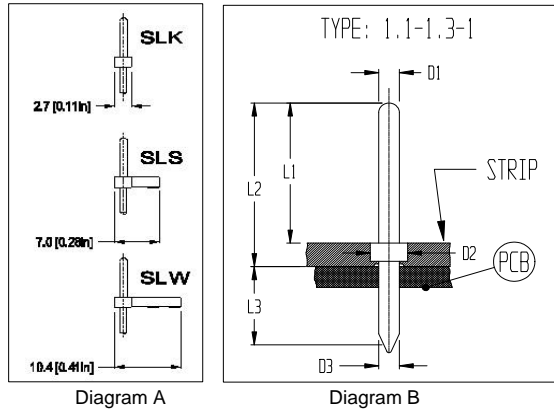

TABLE 1 PIN & STRIP CHOICES				PIN DIAMETER PLUG END	PIN DIAMETER MIDDLE	PIN DIAMETER PCB END	PIN'S PLUG END VS STRIP	PIN'S PLUG END VS PCB	EFFECTIVE PCB PIN LENGTH
APPLICATION STRIP	BLANK PIN ITEM NUMBER	TIN PLATED PIN ITEM NUMBER	SHAPE	D1	D2	D3	L1	L2	L3
971-SLK, SLS OR SLW/02 TO 24-LF	PIN110-011	PIN110-012	STANDARD	1.1	1.3	1	7.8	9.6	4.4
971-SLK, SLS OR SLW/02 TO 24-LF-10.1	PIN110-001	PIN110-003	LONG				10.1	11.9	4.4
971-SLK, SLS OR SLW/02 TO 24-LF-11.7	PIN971-012	TBA	XLONG				11.7	13.5	4.4
971-SLK, SLS OR SLW/02 TO 24-LF-12.4	PIN110-006	PIN110-007	XXLONG				12.4	14.2	3.1
TYPE OF STRIP	NO. OF POLES (02 TO 24)		PLATING	D1	D2	D3	L1	L2	L3

TABLE 2 CHOOSE A PIN PLATING

TIN PLATING AT 5 MICROMETERS IS STANDARD FOR TIN PLATING LEAVE BLANK

- FOR SILVER 5 MICROINCHES ADD -S05
- FOR SILVER 12 MICROINCHES ADD -S12
- FOR SILVER 30 MICROINCHES ADD -S30
- FOR GOLD 5 MICROINCHES ADD -G05
- FOR GOLD 12 MICROINCHES ADD -G12
- FOR GOLD 30 MICROINCHES ADD -G30

TABLE 4 PIN APPLICATION GUIDELINES & SPECIFICATIONS

SEE DIAGRAMS PIN FOR D1, D2, D3, L1, L2 & L3 EXPLANATIONS

- RECOMMENDED PCB HOLE DIAMETER 1.3 MM FOR THIS 1.0 MM PIN
- RECOMMENDED PCB HOLE ALIGNMENT STAGGER 0.3 MM MAXIMUM FOR THIS PCB PIN AND PCB PIN HOLE COMBINATION OF 1.0 AND 1.3 MM.
- PCB PIN LENGTH 3.1 TO 4.4 MM, TABLE 1 COLUMN L3, EXCEPT FOR SPECIAL APPLICATIONS
- PLUG PIN LENGTH ABOVE STRIP TABLE 1 COLUMN L1
- PLUG PIN LENGTH ABOVE PCB TABLE 1 COLUMN L2, IMPORTANT FOR FIT CALCULATIONS

TABLE 3: PREVIOUSLY DEVELOPED PRODUCTS				PIN DIAMETER PLUG END	PIN DIAMETER MIDDLE	PIN DIAMETER PCB END	PIN'S PLUG END VS STRIP	PIN'S PLUG END VS PCB	EFFECTIVE PCB PIN LENGTH
APPLICATION STRIP	BLANK PIN ITEM NUMBER	PLATED PIN ITEM NUMBER	PLATING	D1	D2	D3	L1	L2	L3
971-SLK/05-002	PIN110-001	PIN110-003	SN5	1.1	1.3	1	10.1	11.9	4.4
971-SLK/06-001	PIN110-001	PIN110-003	SN5	1.1	1.3	1	10.1	11.9	4.4
971-SLK/07-001	PIN110-001	PIN110-003	SN5	1.1	1.3	1	10.1	11.9	4.4
971-SLK/03-001	PIN110-001	PIN110-003	SN5	1.1	1.3	1	10.1	11.9	4.4
971-SLK/12-002	PIN110-001	PIN110-003	SN5	1.1	1.3	1	10.1	11.9	4.4
971-SLK/64-002	PIN110-001	PIN110-003	SN5	1.1	1.3	1	10.1	11.9	4.4
971-SLK/10-001	PIN110-001	PIN110-003	SN5	1.1	1.3	1	10.1	11.9	4.4
971-SLK/06-003	PIN110-001	PIN110-014	G05	1.1	1.3	1	10.1	11.9	4.4
971-SLK/08-002	PIN110-001	PIN110-014	G05	1.1	1.3	1	10.1	11.9	4.4
971-SLK/05-003	PIN110-001	PIN110-014	G05	1.1	1.3	1	10.1	11.9	4.4
971-SLK/03-006	PIN110-001	PIN110-014	G05	1.1	1.3	1	10.1	11.9	4.4
971-SLK/06-007	PIN110-001	PIN110-014	G05	1.1	1.3	1	10.1	11.9	4.4
971-SLK/12-004	PIN110-001	PIN110-014	G05	1.1	1.3	1	10.1	11.9	4.4
971-SLK/11-001	PIN110-001	PIN110-014	G05	1.1	1.3	1	10.1	11.9	4.4
971-SLK/10-002	PIN110-001	PIN110-014	G05	1.1	1.3	1	10.1	11.9	4.4
971-SLK/17-001	PIN110-006	PIN110-007	SN5	1.1	1.3	1	12.4	14.2	3.1
971-SLK/03-004	PIN110-006	PIN110-007	SN5	1.1	1.3	1	12.4	14.2	3.1
971-SLK/07-002	PIN110-006	PIN110-007	SN5	1.1	1.3	1	12.4	14.2	3.1
971-SLK/13-001	PIN110-006	PIN110-007	SN5	1.1	1.3	1	12.4	14.2	3.1
971-SLK/03-001	PIN110-006	PIN110-007	SN5	1.1	1.3	1	12.4	14.2	3.1
	PIN110-006	PIN110-013	G05	1.1	1.3	1	12.4	14.2	3.1
971-SLK/04-001	PIN110-011	PIN110-012	SN5	1.1	1.3	1	7.8	9.6	4.4
971-SLK/05-002	PIN110-011	PIN110-012	SN5	1.1	1.3	1	7.8	9.6	4.4
971-SLK/64-004	PIN110-011	PIN110-012	SN5	1.1	1.3	1	7.8	9.6	4.4
971-SLK/64-001	PIN110-011	PIN110-043	G12	1.1	1.3	1	7.8	9.6	4.4
971-SLK/02-002	PIN110-011	PIN110-043	G12	1.1	1.3	1	7.8	9.6	4.4
971-SLK/12-001	PIN110-011	PIN110-044	G05	1.1	1.3	1	7.8	9.6	4.4
971-SLK/64-006	PIN110-011	PIN110-044	G05	1.1	1.3	1	7.8	9.6	4.4
971-SLK/44-001	PIN971-012	PIN971-013	G05	1.1	1.3	1	11.7	13.5	4.4