

Safety Relay Unit

G9SA

The G9SA Series Offers a Complete Line-up of Compact Units.

- Four kinds of 45-mm wide Units are available: A 3-pole model, a 5-pole model, and models with 3 poles and 2 OFF-delay poles, as well as a Two-hand Controller. Also available are 17.5-mm wide Expansion Units with 3 poles and 3 OFF-delay poles.
- Simple expansion connection.
- OFF-delay models have 15-step OFF-delay settings.
- Conforms to EN standards. (BG approval)
- Approved by UL and CSA.
- Both DIN track mounting and screw mounting are possible.



Ordering Information

Emergency-stop Units

Main contacts	Auxiliary contact	Number of input channels	Rated voltage	Model	Category
3PST-NO	SPST-NC	1 channel or 2 channels possible	24 VAC/VDC	G9SA-301	4
5PST-NO			100 to 240 VAC		
		24 VAC/VDC	G9SA-501		
100 to 240 VAC					

Emergency-stop OFF-delay Units

Main contacts	OFF-delay contacts	Auxiliary contact	Number of input channels	OFF-delay time	Rated voltage	Model	Category
3PST-NO	DPST-NO	SPST-NC	1 channel or 2 channels possible	7.5 s	24 VAC/VDC	G9SA-321-T075	Main contacts: 4 OFF-delay contacts: 3
					100 to 240 VAC		
				15 s	24 VAC/VDC	G9SA-321-T15	
	100 to 240 VAC						
	30 s	24 VAC/VDC	G9SA-321-T30				
		100 to 240 VAC					

Note: The following 15-step OFF-delay time settings are available:
 T075: 0.5, 1, 1.5, 2, 2.5, 3, 3.5, 4, 4.5, 5, 5.5, 6, 6.5, 7, and 7.5 s
 T15: 1, 2, 3, 4, 5, 6, 7, 8, 9, 10, 11, 12, 13, 14, and 15 s
 T30: 2, 4, 6, 8, 10, 12, 14, 16, 18, 20, 22, 24, 26, 28, and 30 s

Two-hand Controller

Main contacts	Auxiliary contact	Number of input channels	Rated voltage	Model	Category
3PST-NO	SPST-NC	2 channels	24 VAC/VDC	G9SA-TH301	4
			100 to 240 VAC		

Expansion Unit

The Expansion Unit connects to a G9SA-301, G9SA-501, G9SA-321, or G9SA-TH301.

Main contacts	Auxiliary contact	Model	Category
3PST-NO	SPST-NC	G9SA-EX301	4



Expansion Units with OFF-delay Outputs

The Expansion Unit connects to a G9SA-301, G9SA-501, G9SA-321, or G9SA-TH301.

Main contact form	Auxiliary contact	OFF-delay time	Model	Category
3PST-NO	SPST-NC	7.5 s	G9SA-EX031-T075	3
		15 s	G9SA-EX031-T15	
		30 s	G9SA-EX031-T30	

Note: The following 15-step OFF-delay time settings are available:
 T075: 0.5, 1, 1.5, 2, 2.5, 3, 3.5, 4, 4.5, 5, 5.5, 6, 6.5, 7, and 7.5 s
 T15: 1, 2, 3, 4, 5, 6, 7, 8, 9, 10, 11, 12, 13, 14, and 15 s
 T30: 2, 4, 6, 8, 10, 12, 14, 16, 18, 20, 22, 24, 26, 28, and 30 s

Model Number Structure

■ Model Number Legend

G9SA--
 1 2 3 4 5 6

1. Function

- None: Emergency stop
- EX: Expansion Unit
- TH: Two-hand Controller

2. Contact Configuration (Safety Output)

- 0: None
- 3: 3PST-NO
- 5: 5PST-NO

3. Contact Configuration (OFF-delay Output)

- 0: None
- 2: DPST-NO
- 3: 3PST-NO

4. Contact Configuration (Auxiliary Output)

- 0: None
- 1: SPST-NC

5. Input Configuration (for G9SA-301/501/321)

- None: 1-channel or 2-channel input possible

6. OFF-delay Time (Max. setting time)

- None: No OFF-delay
- T075: 7.5 seconds
- T15: 15 seconds
- T30: 30 seconds

Specifications

■ Ratings

Power Input

Item	G9SA-301/TH301	G9SA-501	G9SA-321-T□
Power supply voltage	24 VAC/VDC: 24 VAC, 50/60 Hz, or 24 VDC 100 to 240 VAC: 100 to 240 VAC, 50/60 Hz		
Operating voltage range	85% to 110% of rated power supply voltage		
Power consumption (See note.)	24 VAC/VDC: 1.8 VA/1.7 W max. 100 to 240 VAC: 9 VA max.	24 VAC/VDC: 2.8 VA/2.6 W max. 100 to 240 VAC: 11 VA max.	24 VAC/VDC: 3.5 VA/3.3 W max. 100 to 240 VAC: 12.5 VA max.

Note: When an Expansion Unit is connected, the power consumption is increased by 2 VA/2 W max.

Inputs

Item	G9SA-301/321-T□/TH301	G9SA-501
Input current (See note.)	40 mA max.	60 mA max.

Note: When an Expansion Unit is connected, the input current is increased by 30 mA max.

Contacts

Item	G9SA-301/501/321-T□/TH301/EX301/EX031-T□
	Resistive load
Rated load	250 VAC, 5 A 30 VDC, 5 A
Rated carry current	5 A

■ Characteristics

Item	G9SA-301/TH301	G9SA-501/321-T□	G9SA-EX301/EX031-T□
Contact resistance (see note 1)	100 mΩ		
Operating time (see note 2)	30 ms max. (not including bounce time)		
Response time (see note 3)	10 ms max. (not including bounce time)		
Insulation resistance (see note 4)	100 MΩ min. (at 500 VDC)		
Dielectric strength	Between different outputs	2,500 VAC, 50/60 Hz for 1 min	
	Between inputs and outputs		
	Between power inputs and outputs		
	Between power inputs and other inputs (only for 100 to 240-V models)		
Vibration resistance	10 to 55 to 10 Hz, 0.375-mm single amplitude (0.75-mm double amplitude)		
Shock resistance	Destruction	300 m/s ²	
	Malfunction	100 m/s ²	
Durability (see note 5)	Mechanical	5,000,000 operations min. (at approx. 7,200 operations/hr)	
	Electrical	100,000 operations min. (at approx. 1,800 operations/hr)	
Minimum permissible load (reference value)	5 VDC, 1 mA		
Ambient operating temperature	-25°C to 55°C (with no icing or condensation)		
Ambient operating humidity	35% to 85%		
Terminal tightening torque	0.98 N·m		
Weight (see note 6)	Approx. 210 g	Approx. 270 g	Approx. 130 g

- Note: 1. The contact resistance was measured with 1 A at 5 VDC using the voltage-drop method.
 2. Includes bounce time.
 3. The response time is the time it takes for the main contact to open after the input is turned OFF.
 4. The insulation resistance was measured with 500 VDC at the same places that the dielectric strength was checked.
 5. The durability is for an ambient temperature of 15°C to 35°C and an ambient humidity of 25% to 75%.
 6. Weight shown is for 24-VAC/VDC type. For 100 to 240-VAC type, add approximately 20 g.

G9SA-301 (100 to 240 VAC) with 2-channel Limit Switch Input/Auto-reset

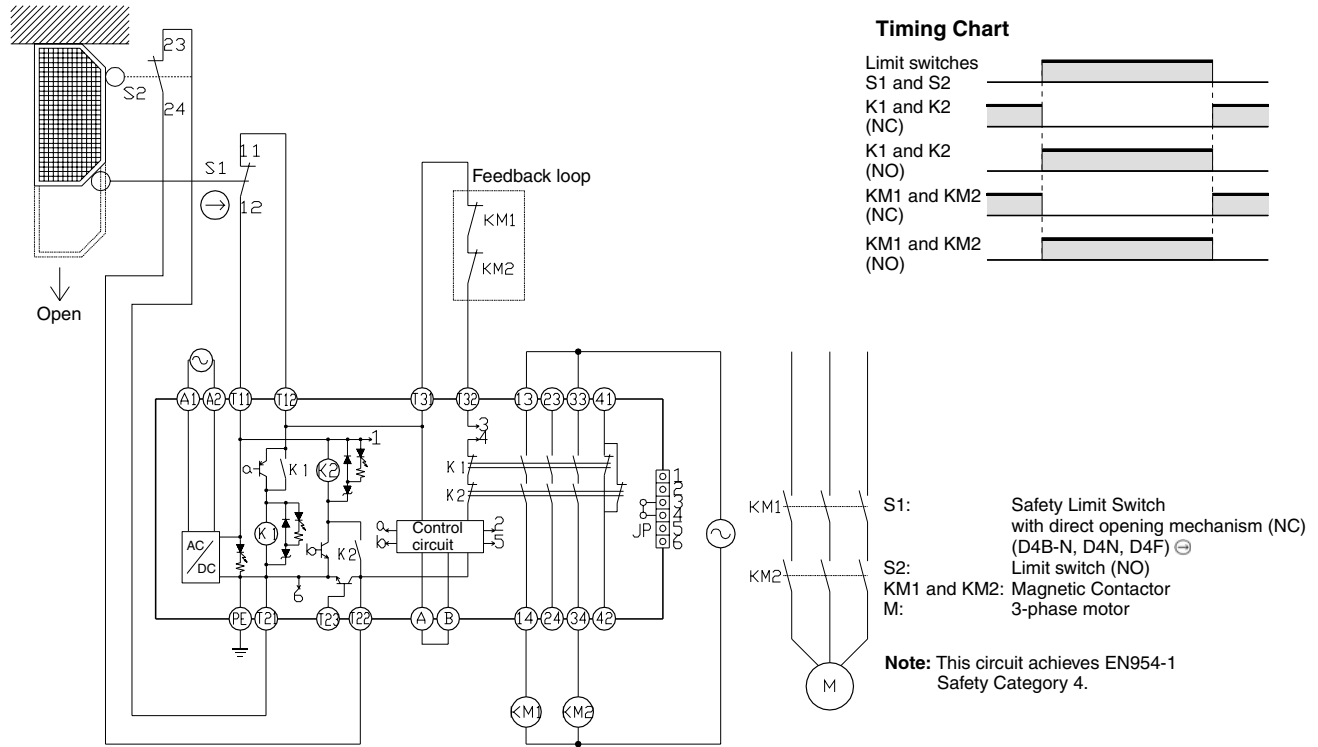

G9SA-301 (24 VAC/VDC) with 2-channel Emergency Stop Switch Input/Manual Reset

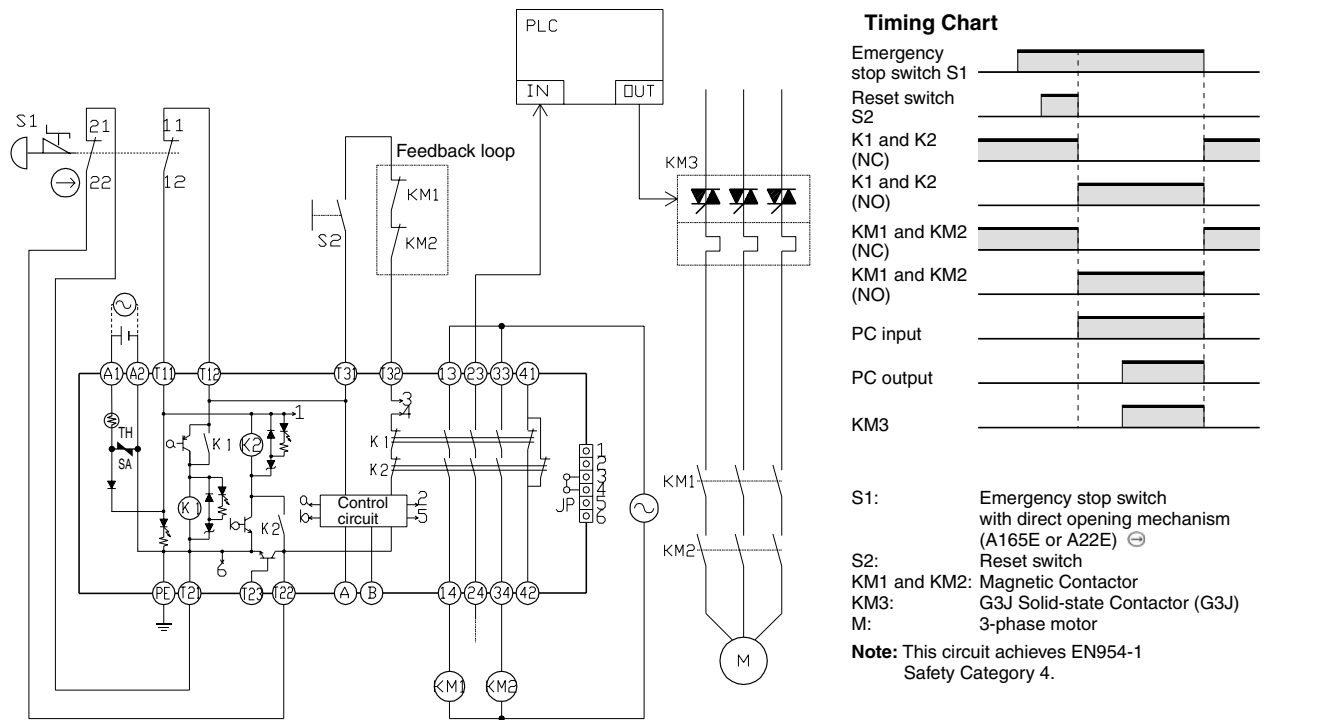

G9SA-321-T□ (24 VAC/VDC) + G9SA-EX031-T□ with 2-channel Limit Switch Input/ Manual Reset

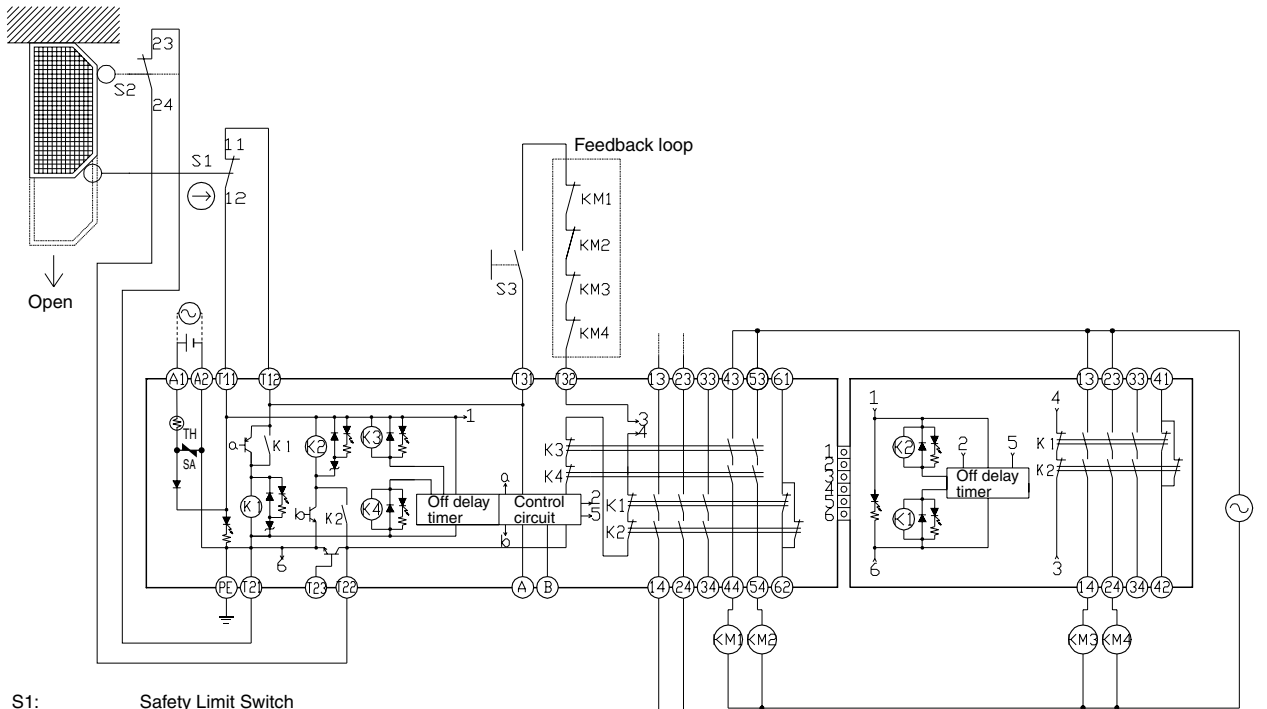

- S1: Safety Limit Switch with direct opening mechanism (NC) (D4B-N, D4N, D4F) ⊖
- S2: Limit switch (NO)
- S3: Reset switch
- KM1, KM2, KM3, and KM4: Magnetic Contactor
- M1, M2: 3-phase motor

Timing Chart

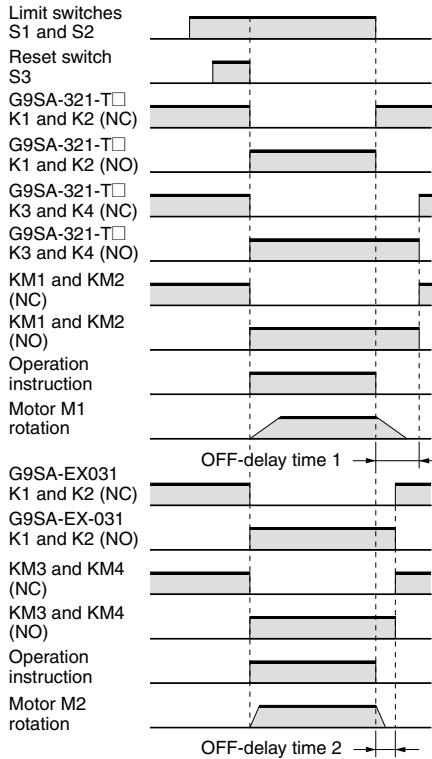

Note: This circuit achieves EN954-1 Safety Category 4. The OFF-delay output, however, achieves EN954-1 Safety Category 3.

Safety Networks and Application Controllers

G9SA

G9SA-501 (24 VAC/VDC) and G9SA-EX301 with 2-channel Limit Switch Input/ Manual Reset

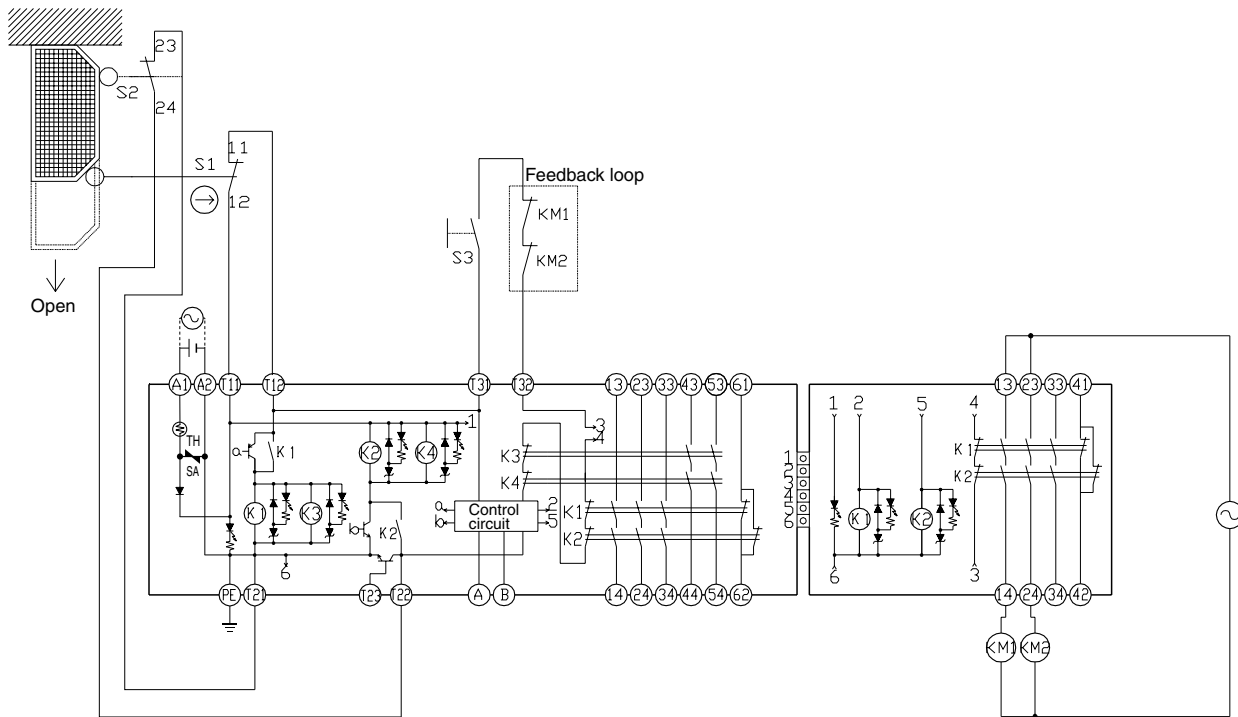

- S1: Safety Limit Switch with direct opening mechanism (NC) (D4B-N, D4N, D4F) ⊖
- S2: Limit switch (NO)
- S3: Reset switch
- KM1 and KM2: Magnetic Contactor
- M: 3-phase motor

Timing Chart

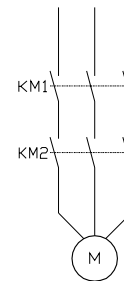
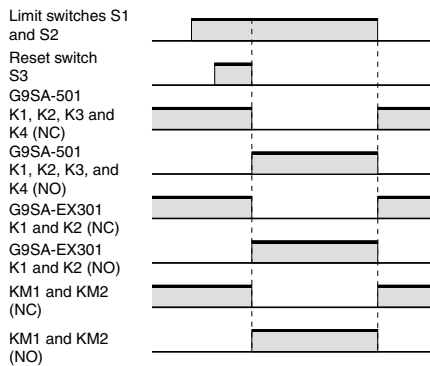

Note: This circuit achieves EN954-1 Safety Category 4.

Dimensions

Note: All units are in millimeters unless otherwise indicated. The diagrams are drawn in perspective.

G9SA-301
 G9SA-501
 G9SA-321-T□
 G9SA-TH301

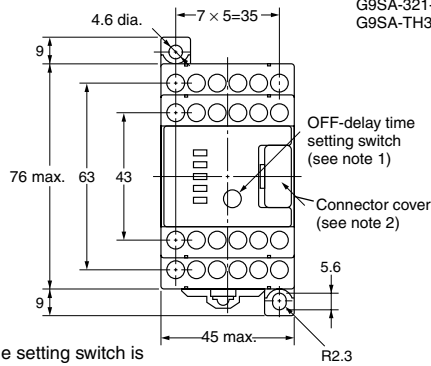
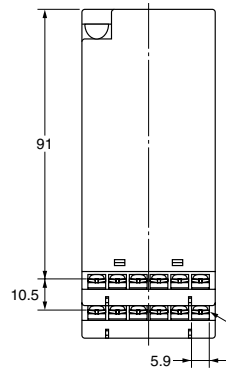
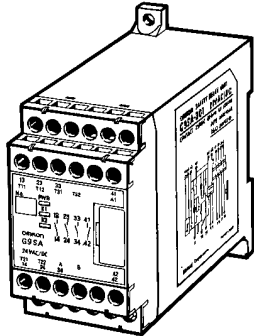

Terminal Arrangement

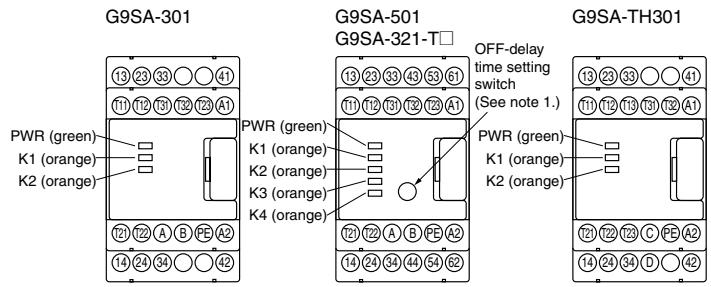

G9SA-301: Twenty, M3
 G9SA-501: Twenty-four, M3
 G9SA-321-T□: Twenty-four, M3
 G9SA-TH301: Twenty-one, M3

Mounting Holes

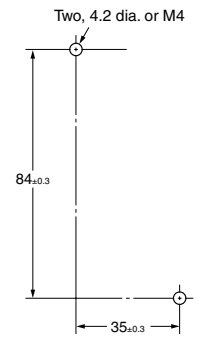

- Note 1:** The OFF-delay time setting switch is found on the G9SA-321-T□ only.
Note 2: The K1 to K4 indicators light when the NO contacts of internal relays K1 to K4 close.
Note 3: Do not remove unless an Expansion Unit is being used.

G9SA-EX301
G9SA-EX031-T

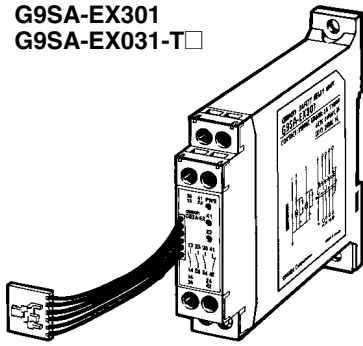

Mounting Holes

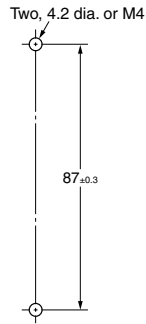

Terminal Arrangement

G9SA-EX301
 G9SA-EX031-T

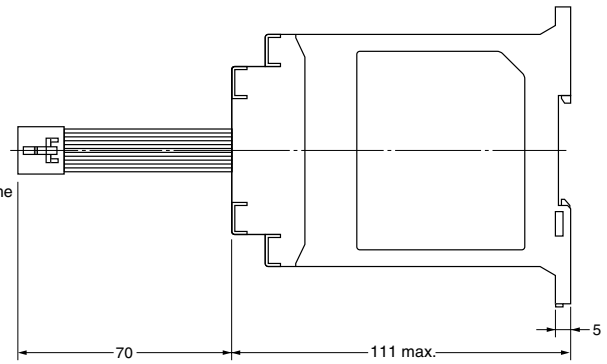
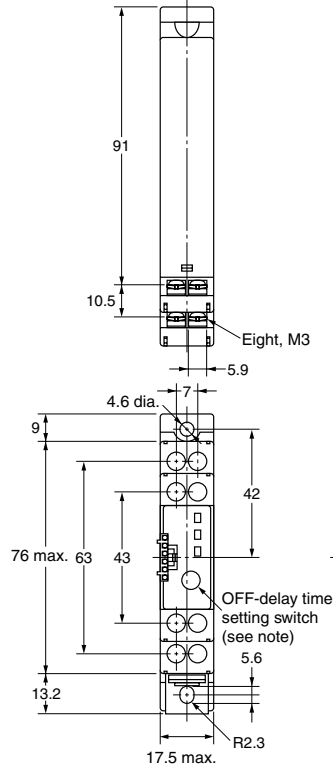
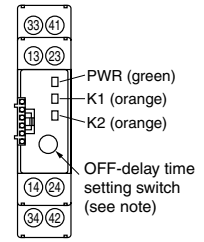

- Note 1:** The OFF-delay time setting switch is found on the G9SA-EX031-T only.
Note 2: The K1 to K4 indicators light when the NO contacts of internal relays K1 to K4 close.

Safety Networks
 and Application
 Controllers

G9SA

Installation

Internal Connections

G9SA-301 (24 VAC/VDC)

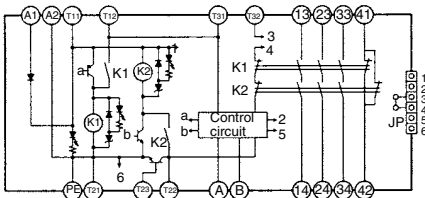

(See note 3.) (See note 1.)

G9SA-301 (100 to 240 VAC)

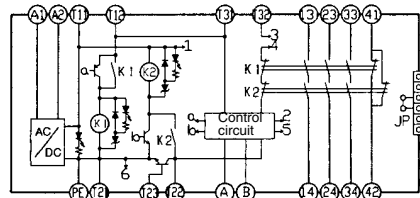

(See note 3.) (See note 1.)

G9SA-501 (24 VAC/VDC)

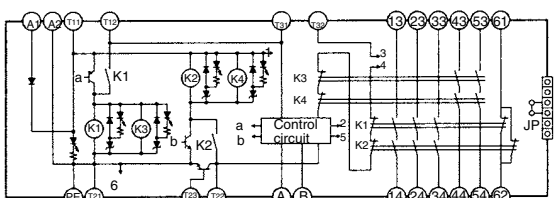

(See note 3.) (See note 1.)

G9SA-501 (100 to 240 VAC)

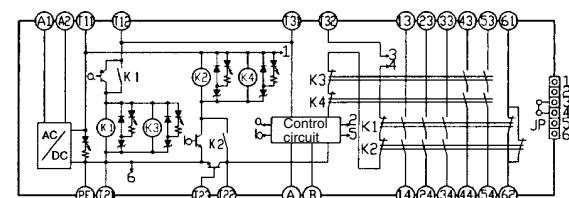

(See note 3.) (See note 1.)

G9SA-321-T (24 VAC/VDC)

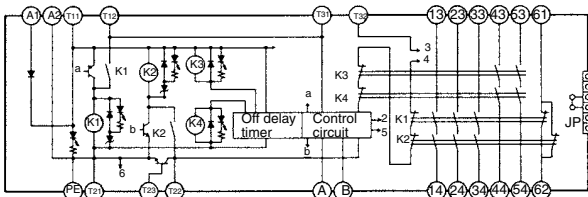

(See note 3.) (See note 1.)

G9SA-321-T (100 to 240 VAC)

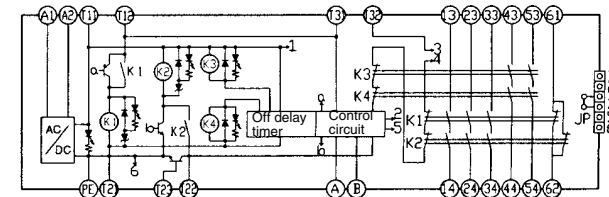

(See note 3.) (See note 1.)

G9SA-TH301 (24 VAC/VDC)

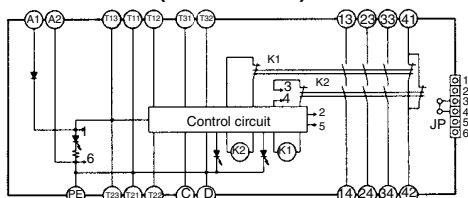

(See note 2.)

G9SA-TH301 (100 to 240 VAC)

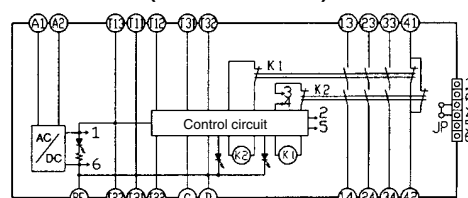

(See note 2.)

G9SA-EX301

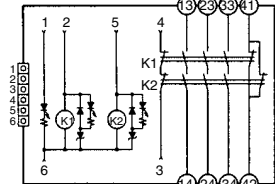

G9SA-EX031-T

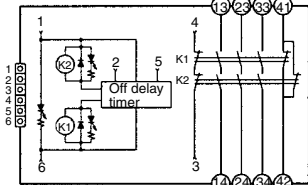

- Note:**
1. Use terminals A and B to switch reset mode.
A to B open: Manual reset
A to B closed: Auto-reset
 2. Use terminals C and D to switch input conditions.
C to D open: DPDT input.
C to D closed: DPST-NC input. (Make sure T11 and T21 are open.)
 3. Use terminal T23 with + common 2-channel input.
When using T23, make sure that T21 and T22 are open. For 1-channel input, make sure T12 and T23 are closed.
 4. With 100 to 240-VAC type, be sure to connect PE to a protective ground. With 24-VAC/VDC type, if the power supply is not connected to a protective ground, be sure to connect PE to a protective ground.
 5. With 24-VAC/VDC type, the power supply terminals A1 and A2 have polarities. A2 is the negative pole.

Safety Precautions

⚠ CAUTION

Turn OFF the G9SA before wiring the G9SA. Do not touch the terminals of the G9SA while the power is turned ON, because the terminals are charged and may cause an electric shock.



■ Precautions for Correct Use

Installation

The G9SA can be installed in any direction.

Wiring

Use the following to wire the G9SA.

Stranded wire: 0.75 to 1.5 mm²

Solid wire: 1.0 to 1.5 mm²

Tighten each screw to a torque of 0.78 to 1.18 N·m, or the G9SA may malfunction or generate heat.

External inputs connected to T11 and T12 or T21 and T22 of the G9SA-301 must be no-voltage contact inputs.

PE is a ground terminal.

When a machine is grounded at the positive, the PE terminal should not be grounded.

Connector Cover

Do not remove the connector cover of the G9SA-301, G9SA-501, G9SA-321-T□, or G9SA-TH301 unless an Expansion Unit is being used.

Mounting Expansion Units

Turn OFF the G9SA before connecting the Expansion Unit.

When an Expansion Unit is being used, remove the connector cover from the G9SA Safety Relay Unit (G9SA-301, G9SA-501, G9SA-321□, or G9SA-TH301) and insert the connector of the Expansion Unit's connector cable.

Mounting Multiple Units

When mounting multiple Units close to each other, the rated current will be 3 A. Do not apply a current higher than 3 A.

Connecting Inputs

If using multiple G9SA models, inputs cannot be made using the same switch. This is also true for other input terminals.

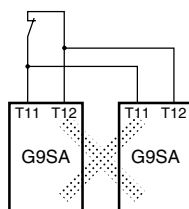

Earth Shorts

A positive thermistor is built into the G9SA circuits, so you can detect earth short breakdowns and breakdown shorts between channel 1 and channel 2. If the short breakdown is canceled, reset is automatic.

■ Applicable Safety Category (EN954-1)

G9SA-series Relays meet the requirements of Safety Category 4 of the EN954-1 standards when they are used as shown in the examples provided by OMRON. The Relays may not meet the standards in some operating conditions. The OFF-delay output of models G9SA-321-T□ and EX031-T□, however, conform to Safety Category 3.

The applicable safety category is determined from the whole safety control system. Make sure that the whole safety control system meets EN954-1 requirements.

■ Approved Standards

The G9SA-301/501/321T□/TH301/EX301/EX031-T□ conform to the following standards.

- EN standards, certified by BG:
 - EN954-1
 - EN60204-1
 - EN574 (G9SA-TH301 only)
- Conformance to EMC (Electromagnetic Compatibility)
 - Certified by TÜV Product Service: G9SA (-TH301) 24 V AC/DC
G9SA-EX301/EX031-T□
 - Certified by TÜV Rheinland: G9SA (-TH301) 100-240 V AC
 - EMI (Emission): EN55011 Group 1 Class A
 - EMS (Immunity): EN61000-6-2
- UL standards: UL508 (Industrial Control Equipment)
- CSA standards: CSA C22.2 No. 14 (Industrial Control Equipment)