

Cosel is one of the world's leading power supply manufacturers, producing high-quality, ultra small size AC-DC and DC-DC converters of the state-of-the-art technologies, and easy-to-use.

[English](#) | [Japanese](#) | [Chinese](#) | [Korean](#) | [German](#) | [French](#) |

[Home](#) > [Product Information](#) > [Noise Filters](#) > SNR Series

● PRODUCT INFORMATION [Selection](#)



Ripple noise attenuation for switch mode power supplies. Most suitable for analog circuits.

❖ [Product Lineup](#)
| [SNR\(10A\)](#) |

❖ [CATALOG DATA DOWN LOAD](#)

❖ [Technical Data](#)

❖ [OPTIONAL PART](#)

❖ [Specifications, circuit diagram and derating curve](#)
[External view](#)

❖ [Characteristic data](#) • [Instruction manual](#) • [About noise filters](#)

SNR Series : Ripple noise attenuation type for switch mode power supplies(DC)

• **Features**

- **50 VDC**
- **Best filter for switch mode power supplies of analog circuits**
- **DIN rail installation type(Optional)**

• **Safety agency approvals**

- **UL60950-1**
- **C-UL(CSA60950-1)**
- **EN60950-1**

• **Environment**

- **RoHS directive**

• **5-year warranty**

SNR series (10A)

SNR -10 -223 -□

① ② ③ ④

- ① Model Name
- ② Rated Current
- ③ Line to ground capacitor code: See table 1.1.

table 1.1 Line to ground capacitor code

Code	Line to ground capacitor (nominal value)
000	Not Provided
223	22000pF

- ④ Options
- D :DIN rail installation type
- T :Terminal block type
- DT :Terminal block and DIN rail type

* The dimensions change when the option is set. Refer to External view.

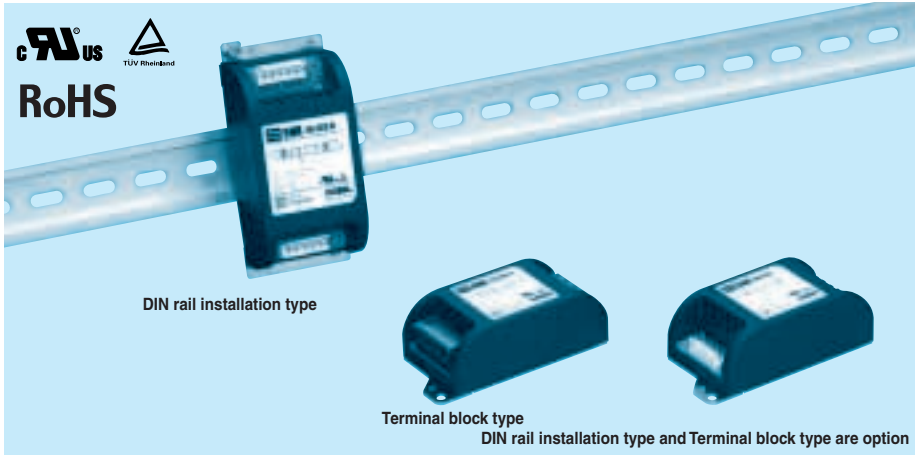

Features of SNR series (10A)

Ripple noise attenuation type for switch mode power supplies(DC)

· 50 VDC

· Best filter for switch mode power supplies of analog circuits

Specifications

No.	Items	SNR-10-223
		Interface:Connector
1	Rated Voltage DC[V]	50
2	Rated Current DC[A]	10 (Peak 20) *1
3	Test Voltage (Terminal-Mounting Plate)	500 VAC (Cutoff Current = 100mA), 1minute at room temperature and humidity
4	Isolation Resistance (Terminal-Mounting Plate)	500 VDC 50MΩ min at room temperature and humidity
5	D.C Resistance[mΩ]	20 max
6	Operating temperature	-40 to +71°C (Refer to Derating Curve)
7	Operating humidity	20 to 95%RH (Non condensing)
8	Storage temperature/humidity	-40 to +75°C/20 to 95%RH (Non condensing)
9	Vibration	10 to 55Hz, 19.6m/s ² (2G), 3min. Period, 1hour each X, Y and Z axis
10	Impact	196.1m/s ² (20G), 11ms Once each X, Y and Z axis
11	Safety agency approvals	UL60950-1, C-UL (CSA60950-1), EN60950-1
12	Case size (without projection) /Mass	52×35×117 mm (W×H×D) /140g max (Option : -D, -T, -DT refer to external view)

*1 Peak current for 10 sec. And Duty 35% max, refer to Instruction Manual 5. In detail.

Circuit Diagram

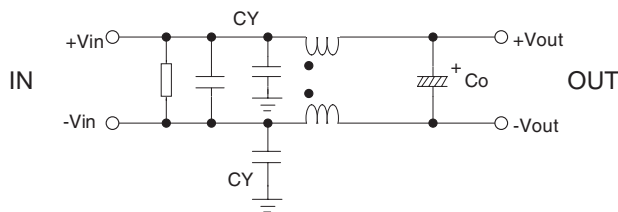

CY : Line to ground capacitor Co : Electrolytic capacitor \equiv : Mounting Plate

■ Expected life : 10 years

Derating Curve

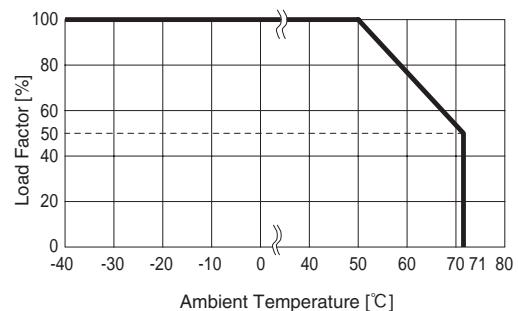

External view

Standard Type

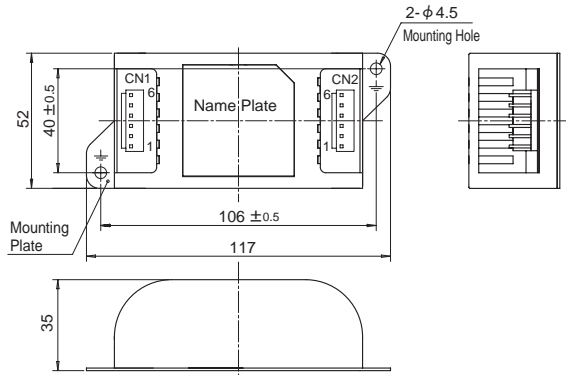

CN1		CN2	
Pin No.	Function	Pin No.	Function
1,2,3	-Vin	1,2,3	-Vout
4,5,6	+Vin	4,5,6	+Vout

I/O Connector	Mating connector	Terminal
CN1,CN2	B6P-VH	Reel:SVH-21T-P1.1
	VHR-6N	Bulk:BVH-21T-P1.1

- ※ Tolerance : ±1
- ※ Mass : 140g or less
- ※ PCB Material /thickness : CEM3 /1.6mm
- ※ Mounting plate : Iron (surface finishing : nickel plating) t=1.0
- ※ Case : PBT
- ※ Dimensions in mm
- ※ Keeping drawing current per pin below 5A (7A at peak current) for CN1 to CN2

(Mfr:J.S.T)

Option harness : Refer to Instruction Manual 4

Terminal block Type

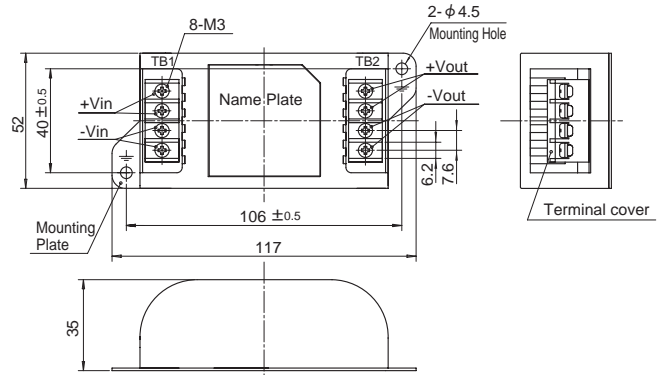

- ※ Tolerance : ±1
- ※ Mass : 150g or less
- ※ PCB Material /thickness : CEM3 /1.6mm
- ※ Mounting plate : Iron (surface finishing : nickel plating) t=1.0
- ※ Case : PBT
- ※ Dimensions in mm
- ※ Terminal block screw tightening torque M3:0.8N · m (8.5kgf · cm) max
- ※ Keeping drawing current per pin below 8A (10A at peak current) for TB1 to TB2

DIN rail installation Type

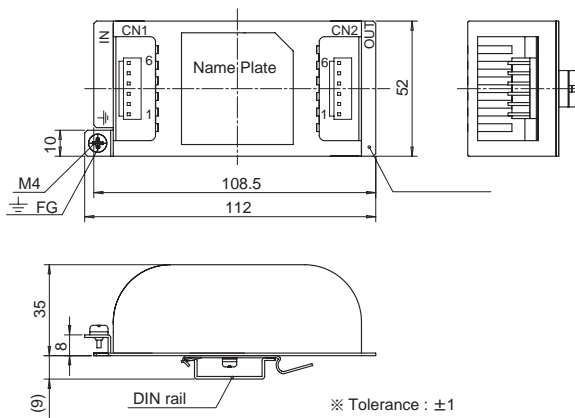

CN1		CN2	
Pin No.	Function	Pin No.	Function
1,2,3	-Vin	1,2,3	-Vout
4,5,6	+Vin	4,5,6	+Vout

I/O Connector	Mating connector	Terminal
CN1,CN2	B6P-VH	Reel:SVH-21T-P1.1
	VHR-6N	Bulk:BVH-21T-P1.1

- ※ Tolerance : ±1
- ※ Mass : 150g or less
- ※ PCB Material /thickness : CEM3 / 1.6mm
- ※ Mounting plate : Iron (surface finishing : nickel plating) t=1.0
- ※ Case : PBT
- ※ Dimensions in mm
- ※ Keeping drawing current per pin below 5A (7A at peak current) for CN1 to CN2

(Mfr:J.S.T)

Option harness : Refer to Instruction Manual 4

Terminal block type+DIN rail installation Type

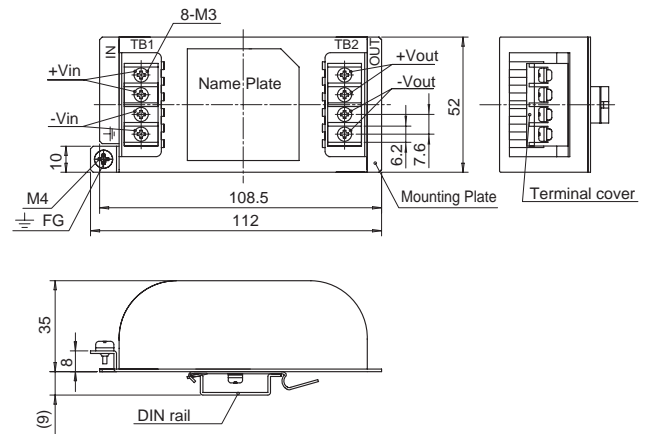

- ※ Tolerance : ±1
- ※ Mass : 160g or less
- ※ PCB Material /thickness : CEM3 /1.6mm
- ※ Mounting plate : Iron (surface finishing : nickel plating) t=1.0
- ※ Case : PBT
- ※ Dimensions in mm
- ※ Terminal block screw tightening torque M3:0.8N · m (8.5kgf · cm) max
- ※ Keeping drawing current per pin below 8A (10A at peak current) for TB1 to TB2

■Note when installing the noise filter on a DIN rail.

When the noise filter is grounded through the DIN rail, the proper noise attenuation may not be achieved.

Be sure to connect the FG terminal of the noise filter body to the earth.

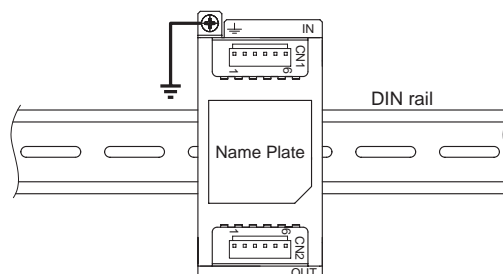

Noise Filter