

PUSH-IN TERMINALS ... PART NO. : T42-1, T28 Series

Push-In Terminals for 0.042" Dia. Holes

Wiring terminals for mounting leads or wires horizontally or vertically (through board hole) points

Connectors require no staking for most applications

Horizontal slot holds up to seven wires, depending upon thickness of wire

Use P149A handle type or P149 shank type insertion tool.

T42-1 Ordering Table

| Part No. | Pkg. Qty. |
|----------|-----------|
| T42-1/C | 100 |
| T42-1/M | 1000 |

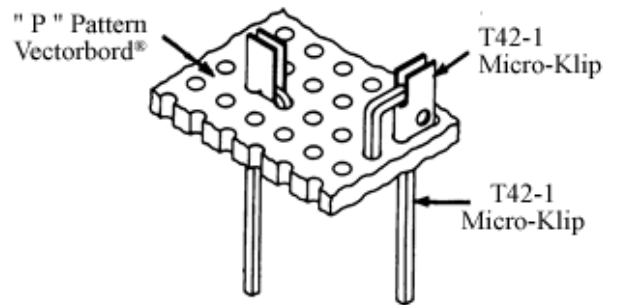
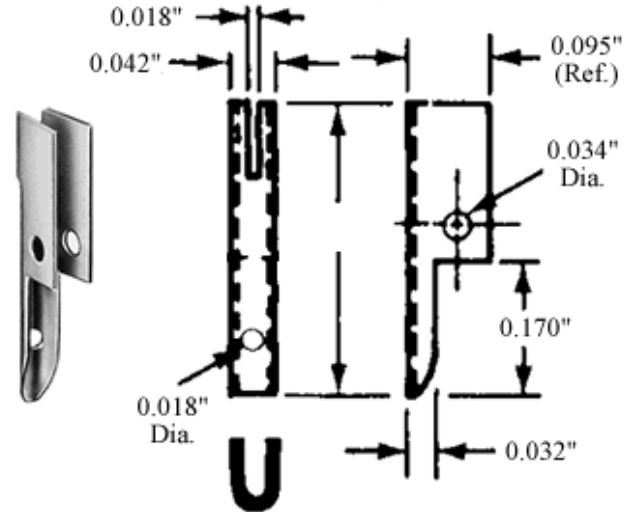

Push-In Terminals for 0.062" Dia. Holes

Wiring terminals for mounting leads or wires horizontally or vertically (through board hole) points

Vertical (longitudinal) slot holes .025" diameter leads or 0.22 gauge wires

Includes .018" diameter tab hole which accepts transistor wires, can be used to hold an anchoring wire

Use P91A insertion tool.

T28 Ordering Table

| Part No. | Pkg. Qty. | A | B |
|----------|-----------|--------|--------|
| T28/C | 100 | 0.437" | 0.237" |
| T28/M | 1000 | 0.437" | 0.237" |

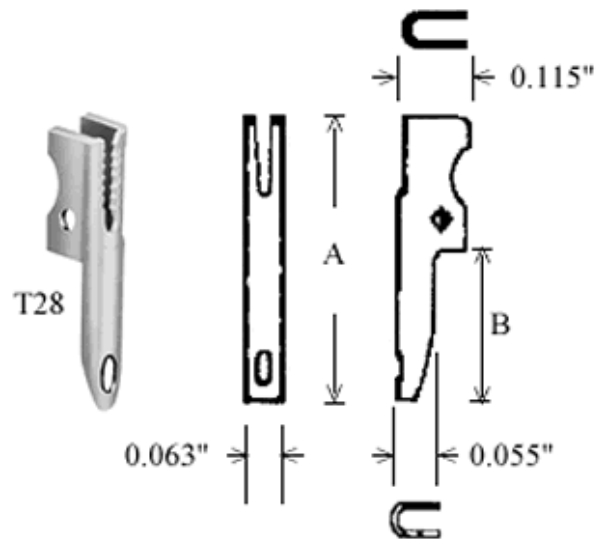

11115 Vanowen St., North Hollywood, CA 91605, USA

Tel.: (818) 985 8208, (800) 423 5659; Fax : (818) 985 7708

**Circbord®, Vectorbord® and VectorPak® are registered trademarks of Vector Electronics & Technology, Inc.
CompactPCI® is a registered trademark of PCIMG. © 2001 Vector Electronics & Technology, Inc. - All Rights Reserved**