

Dual D-type flip-flop with set and reset; positive-edge trigger

74HC74; 74HCT74

FEATURES

- Wide supply voltage range from 2.0 to 6.0 V
- Symmetrical output impedance
- High noise immunity
- Low power dissipation
- Balanced propagation delays
- ESD protection:
HBM EIA/JESD22-A114-A exceeds 2000 V
MM EIA/JESD22-A115-A exceeds 200 V.

GENERAL DESCRIPTION

The 74HC/HCT74 is a high-speed Si-gate CMOS device and is pin compatible with low power Schottky TTL (LSTTL). They are specified in compliance with JEDEC standard no. 7A.

The 74HC/HCT74 are dual positive-edge triggered, D-type flip-flops with individual data (D) inputs, clock (CP) inputs, set (\overline{SD}) and reset (\overline{RD}) inputs; also complementary Q and \overline{Q} outputs.

The set and reset are asynchronous active LOW inputs and operate independently of the clock input. Information on the data input is transferred to the Q output on the LOW-to-HIGH transition of the clock pulse. The D inputs must be stable one set-up time prior to the LOW-to-HIGH clock transition for predictable operation.

Schmitt-trigger action in the clock input makes the circuit highly tolerant to slower clock rise and fall times.

QUICK REFERENCE DATA

GND = 0 V; $T_{amb} = 25\text{ }^{\circ}\text{C}$; $t_r = t_f = 6\text{ ns}$

SYMBOL	PARAMETER	CONDITIONS	TYPICAL		UNIT
			HC	HCT	
t_{PHL}/t_{PLH}	propagation delay nCP to nQ, n \overline{Q}	$C_L = 15\text{ pF}$; $V_{CC} = 5\text{ V}$	14	15	ns
	n \overline{SD} to nQ, n \overline{Q}		15	18	ns
	n \overline{RD} to nQ, n \overline{Q}		16	18	ns
f_{max}	maximum clock frequency		76	59	MHz
C_i	input capacitance		3.5	3.5	pF
C_{PD}	power dissipation capacitance per flip-flop	notes 1 and 2	24	29	pF

Notes

1. C_{PD} is used to determine the dynamic power dissipation (P_D in μW).

$$P_D = C_{PD} \times V_{CC}^2 \times f_i \times N + \Sigma(C_L \times V_{CC}^2 \times f_o) \text{ where:}$$

f_i = input frequency in MHz;

f_o = output frequency in MHz;

C_L = output load capacitance in pF;

V_{CC} = supply voltage in Volts;

N = total load switching outputs;

$\Sigma(C_L \times V_{CC}^2 \times f_o)$ = sum of the outputs.

2. For 74HC74 the condition is $V_I = \text{GND to } V_{CC}$.

For 74HCT74 the condition is $V_I = \text{GND to } V_{CC} - 1.5\text{ V}$.

Dual D-type flip-flop with set and reset; positive-edge trigger

74HC74; 74HCT74

FUNCTION TABLES

Table 1 See note 1

INPUT				OUTPUT	
\overline{SD}	\overline{RD}	CP	D	Q	\overline{Q}
L	H	X	X	H	L
H	L	X	X	L	H
L	L	X	X	H	H

Table 2 See note 1

INPUT				OUTPUT	
\overline{SD}	\overline{RD}	CP	D	Q _{n+1}	\overline{Q}_{n+1}
H	H	↑	L	L	H
H	H	↑	H	H	L

Note

- H = HIGH voltage level;
L = LOW voltage level;
X = don't care;
↑ = LOW-to-HIGH CP transition;
Q_{n+1} = state after the next LOW-to-HIGH CP transition.

ORDERING INFORMATION

TYPE NUMBER	PACKAGE				
	TEMPERATURE RANGE	PINS	PACKAGE	MATERIAL	CODE
74HC74N	-40 to +125 °C	14	DIP14	plastic	SOT27-1
74HCT74N	-40 to +125 °C	14	DIP14	plastic	SOT27-1
74HC74D	-40 to +125 °C	14	SO14	plastic	SOT108-1
74HCT74D	-40 to +125 °C	14	SO14	plastic	SOT108-1
74HC74DB	-40 to +125 °C	14	SSOP14	plastic	SOT337-1
74HCT74DB	-40 to +125 °C	14	SSOP14	plastic	SOT337-1
74HC74PW	-40 to +125 °C	14	TSSOP14	plastic	SOT402-1
74HCT74PW	-40 to +125 °C	14	TSSOP14	plastic	SOT402-1
74HC74BQ	-40 to +125 °C	14	DHVQFN14	plastic	SOT762-1
74HCT74BQ	-40 to +125 °C	14	DHVQFN14	plastic	SOT762-1

Dual D-type flip-flop with set and reset; positive-edge trigger

74HC74; 74HCT74

RECOMMENDED OPERATING CONDITIONS

SYMBOL	PARAMETER	CONDITIONS	74HC74			74HCT74			UNIT
			MIN.	TYP.	MAX.	MIN.	TYP.	MAX.	
V_{CC}	supply voltage		2.0	5.0	6.0	4.5	5.0	5.5	V
V_I	input voltage		0	–	V_{CC}	0	–	V_{CC}	V
V_O	output voltage		0	–	V_{CC}	0	–	V_{CC}	V
T_{amb}	operating ambient temperature		–40	+25	+125	–40	+25	+125	°C
t_r, t_f	input rise and fall times	$V_{CC} = 2.0\text{ V}$	–	–	1000	–	–	500	ns
		$V_{CC} = 4.5\text{ V}$	–	6.0	500	–	6.0	500	ns
		$V_{CC} = 6.0\text{ V}$	–	–	400	–	–	500	ns

LIMITING VALUES

In accordance with the Absolute Maximum Rating System (IEC 60134); voltages are referenced to GND (ground = 0 V).

SYMBOL	PARAMETER	CONDITIONS	MIN.	MAX.	UNIT
V_{CC}	supply voltage		–0.5	+7.0	V
I_{IK}	input diode current	$V_I < -0.5\text{ V}$ or $V_I > V_{CC} + 0.5\text{ V}$; note 1	–	±20	mA
I_{OK}	output diode current	$V_O < -0.5\text{ V}$ or $V_O > V_{CC} + 0.5\text{ V}$; note 1	–	±20	mA
I_O	output source or sink current	$-0.5\text{ V} < V_O < V_{CC} + 0.5\text{ V}$; note 1	–	±25	mA
I_{CC}, I_{GND}	V_{CC} or GND current		–	±100	mA
T_{stg}	storage temperature		–65	+150	°C
P_{tot}	power dissipation	$T_{amb} = -40\text{ to }+125\text{ °C}$; note 2	–	500	mW

Notes

- The input and output voltage ratings may be exceeded if the input and output current ratings are observed.
- For SO14 packages: above 70 °C derate linearly with 8 mW/K.
For SSOP14 and TSSOP14 packages: above 60 °C derate linearly with 5.5 mW/K.
For DHVQFN14 packages: above 60 °C derate linearly with 4.5 mW/K.
For DIP14 packages: above 70 °C derate linearly with 12 mW/K.

Dual D-type flip-flop with set and reset;
positive-edge trigger

74HC74; 74HCT74

DC CHARACTERISTICS

Family 74HC

At recommended operating conditions; voltages are referenced to GND (ground = 0 V).

SYMBOL	PARAMETER	TEST CONDITIONS		MIN.	TYP.	MAX.	UNIT
		WAVEFORMS	V _{CC} (V)				
T_{amb} = -40 to +85 °C; note 1							
V _{IH}	HIGH-level input voltage		2.0	1.5	1.2	–	V
			4.5	3.15	2.4	–	V
			6.0	4.2	3.2	–	V
V _{IL}	LOW-level input voltage		2.0	–	0.8	0.5	V
			4.5	–	2.1	1.35	V
			6.0	–	2.8	1.8	V
V _{OH}	HIGH-level output voltage	V _I = V _{IH} or V _{IL} I _O = -4.0 mA	4.5	3.84	4.32	–	V
		I _O = -5.2 mA	6.0	5.34	5.81	–	V
V _{OL}	LOW-level output voltage	V _I = V _{IH} or V _{IL} I _O = 4.0 mA	4.5	–	0.15	0.33	V
		I _O = 5.2 mA	6.0	–	0.16	0.33	V
I _{LI}	input leakage current	V _I = V _{CC} or GND	6.0	–	–	±1.0	μA
I _{CC}	quiescent supply current	V _I = V _{CC} or GND; I _O = 0	6.0	–	–	40	μA
T_{amb} = -40 to +125 °C							
V _{IH}	HIGH-level input voltage		2.0	1.5	–	–	V
			4.5	3.15	–	–	V
			6.0	4.2	–	–	V
V _{IL}	LOW-level input voltage		2.0	–	–	0.5	V
			4.5	–	–	1.35	V
			6.0	–	–	1.8	V
V _{OH}	HIGH-level output voltage	V _I = V _{IH} or V _{IL} I _O = -4.0 mA	4.5	3.7	–	–	V
		I _O = -5.2 mA	6.0	5.2	–	–	V
V _{OL}	LOW-level output voltage	V _I = V _{IH} or V _{IL} I _O = 4.0 mA	4.5	–	–	0.4	V
		I _O = 5.2 mA	6.0	–	–	0.4	V
I _{LI}	input leakage current	V _I = V _{CC} or GND	6.0	–	–	±1.0	μA
I _{CC}	quiescent supply current	V _I = V _{CC} or GND; I _O = 0	6.0	–	–	80	μA

Note

1. All typical values are measured at T_{amb} = 25 °C.

Dual D-type flip-flop with set and reset;
positive-edge trigger

74HC74; 74HCT74

AC CHARACTERISTICS

Family 74HC

GND = 0 V; $t_r = t_f = 6$ ns; $C_L = 50$ pF.

SYMBOL	PARAMETER	TEST CONDITIONS		MIN.	TYP.	MAX.	UNIT
		WAVEFORMS	V _{CC} (V)				
T_{amb} = -40 to +85 °C							
t _{PHL} /t _{PLH}	propagation delay nCP to nQ, n \bar{Q}	see Fig.7	2.0	–	47	220	ns
			4.5	–	17	44	ns
			6.0	–	14	37	ns
	propagation delay nSD to nQ, n \bar{Q}	see Fig.8	2.0	–	50	250	ns
			4.5	–	18	50	ns
			6.0	–	14	43	ns
	propagation delay nRD to nQ, n \bar{Q}	see Fig.8	2.0	–	52	250	ns
			4.5	–	19	50	ns
			6.0	–	15	43	ns
t _{THL} /t _{TLH}	output transition time	see Fig.7	2.0	–	19	95	ns
			4.5	–	7	19	ns
			6.0	–	6	16	ns
t _w	clock pulse width HIGH or LOW	see Fig.7	2.0	100	19	–	ns
			4.5	20	7	–	ns
			6.0	17	6	–	ns
	set or reset pulse width LOW	see Fig.8	2.0	100	19	–	ns
			4.5	20	7	–	ns
			6.0	17	6	–	ns
t _{rem}	removal time set or reset	see Fig.8	2.0	40	3	–	ns
			4.5	8	1	–	ns
			6.0	7	1	–	ns
t _{su}	set-up time nD to nCP	see Fig.7	2.0	75	6	–	ns
			4.5	15	2	–	ns
			6.0	13	2	–	ns
t _h	hold time nCP to nD	see Fig.7	2.0	3	–6	–	ns
			4.5	3	–2	–	ns
			6.0	3	–2	–	ns
f _{max}	maximum clock pulse frequency	see Fig.7	2.0	4.8	23	–	MHz
			4.5	24	69	–	MHz
			6.0	28	82	–	MHz

Dual D-type flip-flop with set and reset;
positive-edge trigger

74HC74; 74HCT74

SYMBOL	PARAMETER	TEST CONDITIONS		MIN.	TYP.	MAX.	UNIT
		WAVEFORMS	V _{CC} (V)				
T_{amb} = -40 to +125 °C							
t _{PHL} /t _{PLH}	propagation delay nCP to nQ, n \bar{Q}	see Fig.7	2.0	–	–	265	ns
			4.5	–	–	53	ns
			6.0	–	–	45	ns
	propagation delay nSD to nQ, n \bar{Q}	see Fig.8	2.0	–	–	300	ns
			4.5	–	–	60	ns
			6.0	–	–	51	ns
	propagation delay nRD to nQ, n \bar{Q}	see Fig.8	2.0	–	–	300	ns
			4.5	–	–	60	ns
			6.0	–	–	51	ns
t _{THL} /t _{TLH}	output transition time	see Fig.7	2.0	–	–	110	ns
			4.5	–	–	22	ns
			6.0	–	–	19	ns
t _w	clock pulse width HIGH or LOW	see Fig.7	2.0	120	–	–	ns
			4.5	24	–	–	ns
			6.0	20	–	–	ns
t _w	set or reset pulse width LOW	see Fig.8	2.0	120	–	–	ns
			4.5	24	–	–	ns
			6.0	20	–	–	ns
t _{rem}	removal time set or reset	see Fig.8	2.0	45	–	–	ns
			4.5	9	–	–	ns
			6.0	8	–	–	ns
t _{su}	set-up time nD to nCP	see Fig.7	2.0	90	–	–	ns
			4.5	18	–	–	ns
			6.0	15	–	–	ns
t _h	hold time nCP to nD	see Fig.7	2.0	3	–	–	ns
			4.5	3	–	–	ns
			6.0	3	–	–	ns
f _{max}	maximum clock pulse frequency	see Fig.7	2.0	4.0	–	–	MHz
			4.5	20	–	–	MHz
			6.0	24	–	–	MHz

Dual D-type flip-flop with set and reset;
positive-edge trigger

74HC74; 74HCT74

PACKAGE OUTLINES

DIP14: plastic dual in-line package; 14 leads (300 mil)

SOT27-1

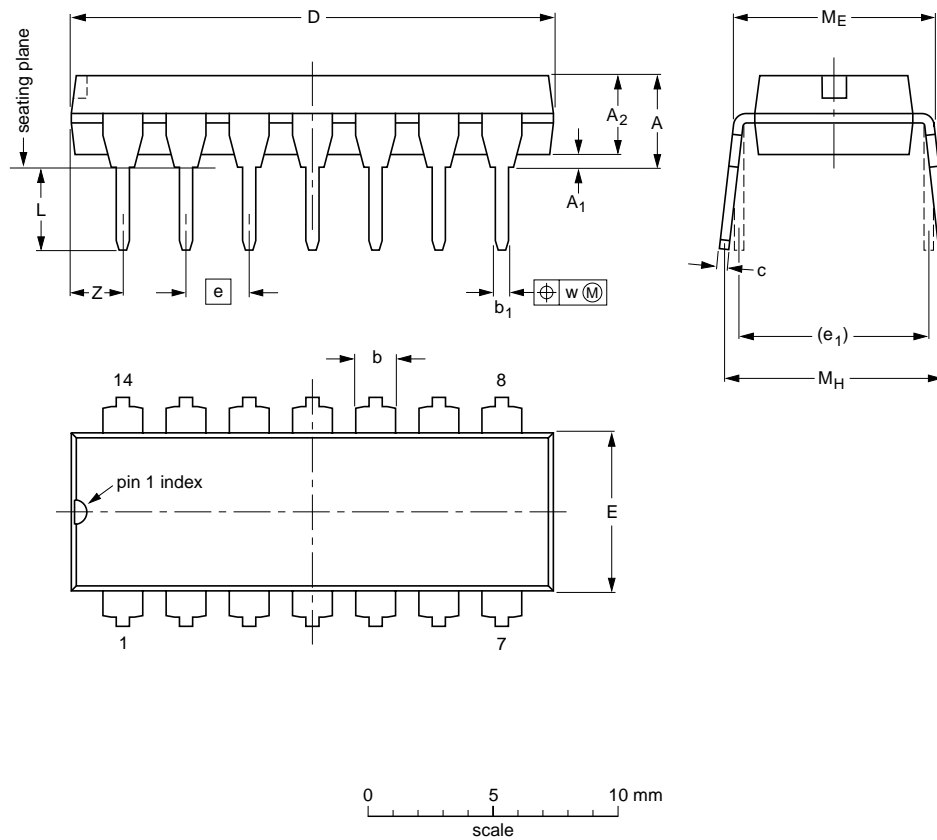

DIMENSIONS (inch dimensions are derived from the original mm dimensions)

UNIT	A max.	A ₁ min.	A ₂ max.	b	b ₁	c	D ⁽¹⁾	E ⁽¹⁾	e	e ₁	L	M _E	M _H	w	Z ⁽¹⁾ max.
mm	4.2	0.51	3.2	1.73 1.13	0.53 0.38	0.36 0.23	19.50 18.55	6.48 6.20	2.54	7.62	3.60 3.05	8.25 7.80	10.0 8.3	0.254	2.2
inches	0.17	0.02	0.13	0.068 0.044	0.021 0.015	0.014 0.009	0.77 0.73	0.26 0.24	0.1	0.3	0.14 0.12	0.32 0.31	0.39 0.33	0.01	0.087

Note

1. Plastic or metal protrusions of 0.25 mm (0.01 inch) maximum per side are not included.

OUTLINE VERSION	REFERENCES			EUROPEAN PROJECTION
	IEC	JEDEC	JEITA	
SOT27-1	050G04	MO-001	SC-501-14	

Dual D-type flip-flop with set and reset;
positive-edge trigger

74HC74; 74HCT74

SO14: plastic small outline package; 14 leads; body width 3.9 mm

SOT108-1

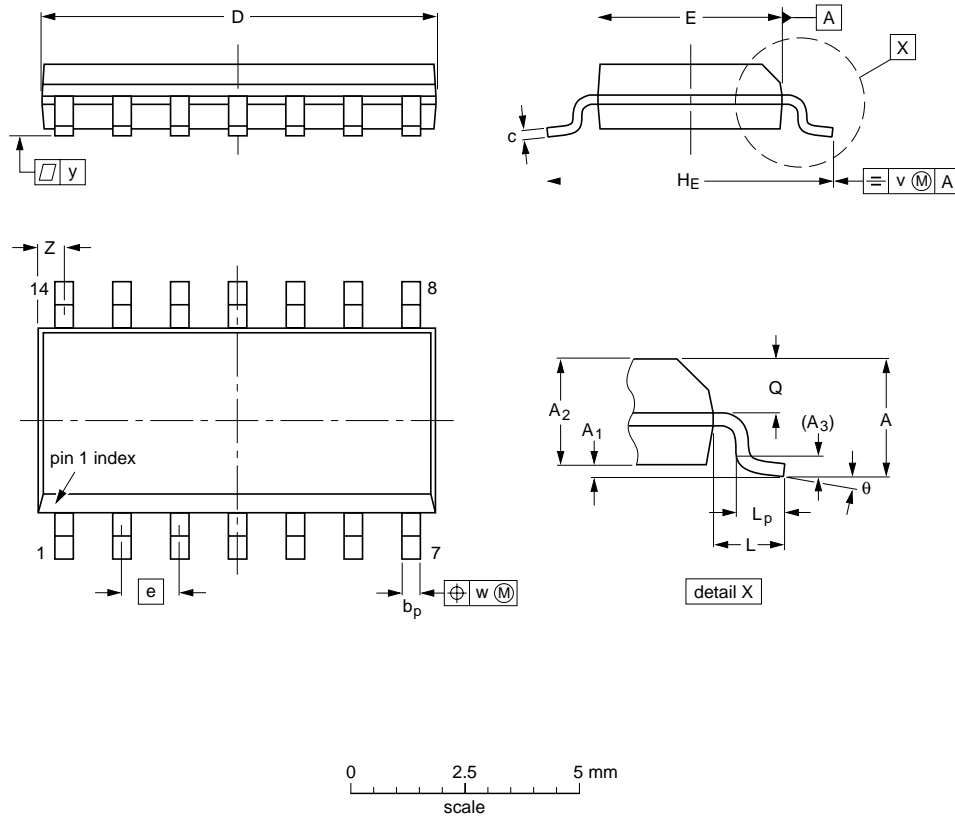

DIMENSIONS (inch dimensions are derived from the original mm dimensions)

UNIT	A max.	A ₁	A ₂	A ₃	b _p	c	D ⁽¹⁾	E ⁽¹⁾	e	H _E	L	L _p	Q	v	w	y	Z ⁽¹⁾	θ
mm	1.75 0.10	0.25 1.25	1.45 1.25	0.25	0.49 0.36	0.25 0.19	8.75 8.55	4.0 3.8	1.27	6.2 5.8	1.05	1.0 0.4	0.7 0.6	0.25	0.25	0.1	0.7 0.3	8° 0°
inches	0.069	0.010 0.004	0.057 0.049	0.01	0.019 0.014	0.0100 0.0075	0.35 0.34	0.16 0.15	0.05	0.244 0.228	0.041	0.039 0.016	0.028 0.024	0.01	0.01	0.004	0.028 0.012	

Note

1. Plastic or metal protrusions of 0.15 mm (0.006 inch) maximum per side are not included.

OUTLINE VERSION	REFERENCES				EUROPEAN PROJECTION
	IEC	JEDEC	JEITA		
SOT108-1	076E06	MS-012			