

REV	DATE	DESCRIPTION	APP

HEX EXTENDER
QTY: 2 EACH

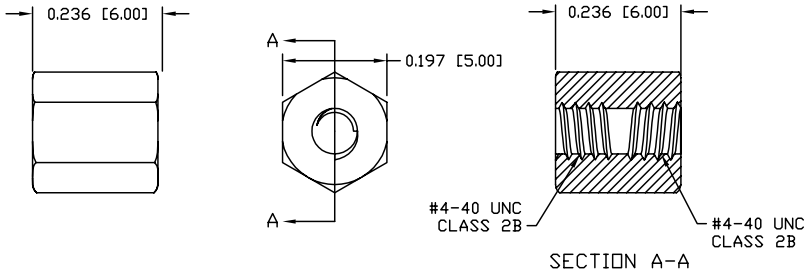

SADDLE WASHER
QTY: 2 EACH

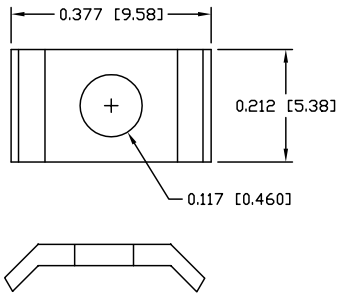

CAPTIVE SCREW
QTY: 2 EACH

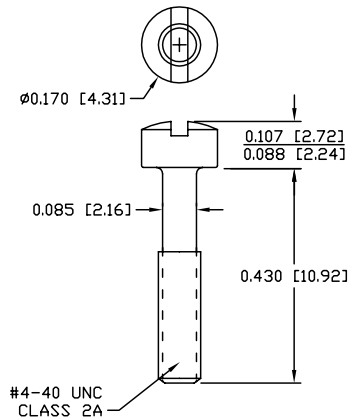

HEX EXTENDER

1. MATERIAL: BRASS
2. FINISH: NICKEL PLATE
3. DIMENSIONS: INCHES [MM]
4. TOLERANCE: ±0.005 [0.127] UNLESS OTHERWISE STATED

SADDLE WASHER

1. MATERIAL: C1008 - C1010 STEEL
2. FINISH: CLEAR ZINC (HEXAVALENT CHROMIUM FREE)
3. DIMENSIONS: INCHES [MM]
4. TOLERANCE: ±0.010 [0.254] UNLESS OTHERWISE STATED

CAPTIVE SCREW

1. MATERIAL: 12L14 FREE-MACHINING STEEL
2. FINISH: CLEAR ZINC (HEXAVALENT CHROMIUM FREE)
3. DIMENSIONS: INCHES [MM]
4. TOLERANCE: ±0.010 [0.254] UNLESS OTHERWISE STATED

UNLESS OTHERWISE SPECIFIED	SIGNATURES	DATE
1. DIMENSIONS IN INCHES [MM] 2. TOLERANCE UNLESS OTHERWISE SPECIFIED .XXX ± .005 [0.127] .XX ± .02 [0.508] .X ± .03 [0.762] FRACT. ± 1/32 ANGULAR ± 1/2°	DRAWN JSD	28-JUL-06
	CHECKED SCN	28-JUL-06
	ISSUED	28-JUL-06

Northern Technologies			THIS DRAWING IS THE PROPERTY OF NORTHERN TECHNOLOGIES AND SHOULD NOT BE REPRODUCED WITHOUT NORTHERN TECHNOLOGIES WRITTEN PERMISSION.	
PART NUMBER C89E014050			DESCRIPTION #4-40 HEX EXTENDER KIT RoHS	
SHEET 1	CODE 520_208	DWG NO. 0002-520-208		
SCALE N.T.S.			SHEET 1 OF 1	

THIS IS A CONTROLLED DOCUMENT AND IS SUBJECT TO CHANGE. CONTACT NORTHERN TECHNOLOGIES ENGINEERING FOR THE LATEST REVISION.