

Switching Power Supply Type SPD 18W DIN rail mounting

CARLO GAVAZZI



- Universal AC input full range
- Installation on DIN rail 7.5 or 15mm
- Short circuit protection
- Overload protection
- High efficiency
- LED indicator for DC power ON
- LED indication for DC low
- Internal input filter
- CE, TUV approved and cULus Listed

Product Description

The Switching power supplies SPD series are specially designed to be used in all automation application where the

installation is on a DIN rail and compact dimensions and performance are a must.

Ordering Key

SP D 24 18 1 B

Model _____
 Mounting (D = Din rail) _____
 Output voltage _____
 Output power _____
 Input Type _____
 Optional features _____

Input type: 1= single phase

Approvals



Optional Features

Description	code
Spring connectors	B

Output performances

Model	Output Voltage (VDC)	Output Current (A)	Output Power (W)	Voltage Trim Range		DC on LED (VDC)	DC low LED (VDC)		Typical Efficiency
				Min. (VDC)	Max. (VDC)		Min.	Max	
SPD05	5	3	15	4.5	5.75	4.5	3.75	4.5	75%
SPD12	12	1.5	18	10.8	13.8	10.8	9	10.8	77%
SPD15	15	1.2	18	13.5	17.25	13.5	11.25	13.5	77%
SPD24	24	0.75	18	21.3	28.8	21.6	18	21.6	77%

Output data

Line regulation	± 1%	Output Voltage accuracy	± 1%
Load regulation	± 2%	Temperature coefficient	± 0.02%/°C
Minimum load	0	Hold up Time Vi = 115Vac	20ms
Transient recovery time	300µs	Hold up time Vi = 230Vac	75ms
Ripple and noise	50mVpp		

Input data

Rated input voltage	100 - 240	Frequency range	47- 63 Hz
Voltage range		Inrush current	
AC	90 - 265 Vac	Vi = 115Vac	10A
DC	120 - 370 Vdc	Vi = 230Vac	18A

Specifications are subject to change without notice



Controls and Protections

Overload	110 – 135%	Oversvoltage Protection	125 – 145%
Input Fuse	T2A/250Vac internal*	Output Short Circuit	Hiccup mode

General data (@ nominal line, full load, 25°C)

Ambient temperature	-10°C to 71°C	Switching frequency	100kHz
Derating (>60°C to +71°C)	3%/°C	MTBF (MIL-HDBK-217F)	800.000h
Ambient humidity	20 - 90%RH	Case material	Plastic: PC, UL94-V0
Storage	-25°C to +85°C	Dimensions L x W x D	90 x 22.5 x 115
Protection degree	IP20	Weight	150g
Cooling	Free air convection		

Norms and Standards

Insulation voltage I / O	3.000Vac min.	CE	EN50081-1 / EN55022 Class B EN50082-1 / EN55024 EN61000-3-2 EN61000-3-3
Insulation resistance	100Mohm min.		
UL / cUL	UL508, UL60950-1, UL1310 Class 2 Recognised		
TUV	EN60950-1		
* fuse not replaceable by user			

Block diagrams

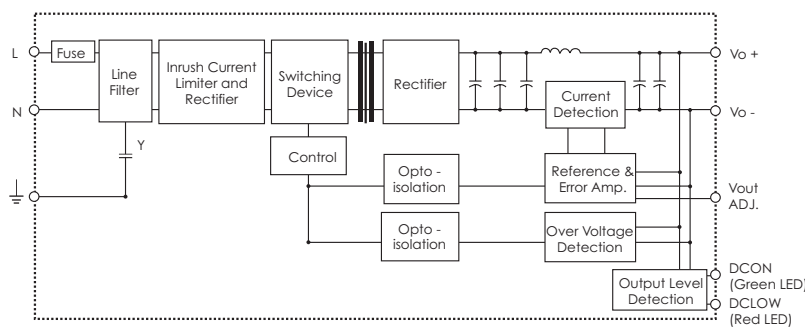

Pin assignement and front controls

Pin No.	Designation	Description
1	V+	Positive output terminal
2	V-	Negative output terminal
3	GND	Ground terminal to minimise High frequency emissions
4	N	Neutral input (no polarity with DC input)
5	L	Phase input (no polarity with DC input)
	Vout ADJ.	Trimmer for fine output voltage adjustment
	ON	DC output ready LED
	LO	DC low indicator LED

Derating Diagram

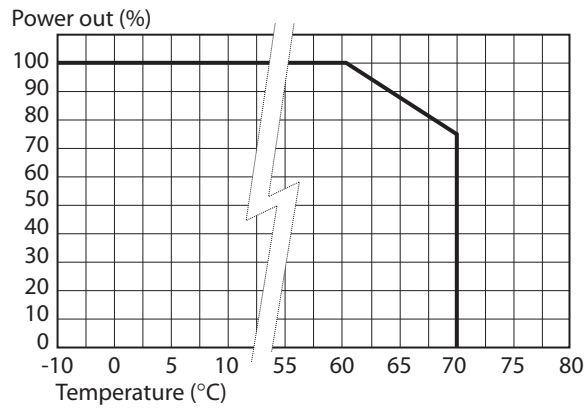

Mechanical Drawings

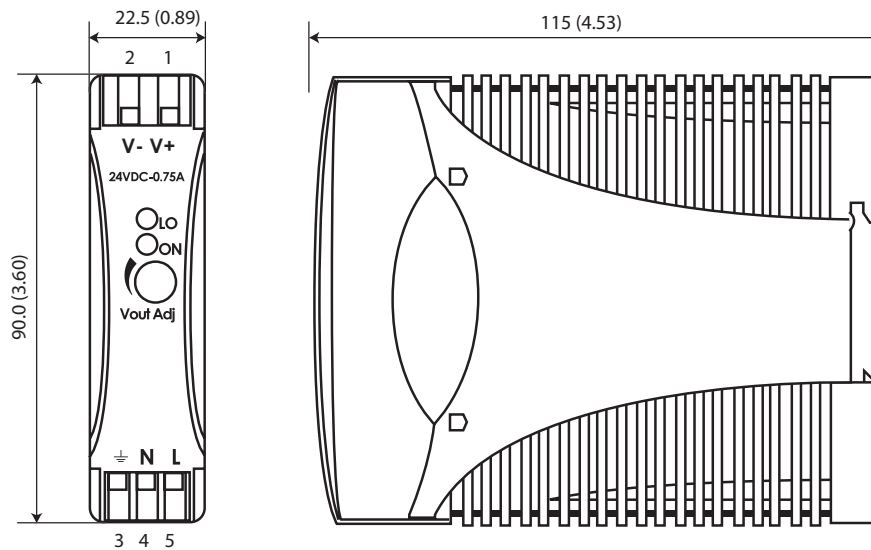

Installation

Ventilation and cooling	Normal convection All sides 25mm free space for cooling is recommended
Connector size range	Solid: 0.2 – 2mm ² (AWG24-14) (use copper conductors only)

Sense

Switch

Control

Safety

Fieldbus

SPD Switching Power Supplies

CARLO GAVAZZI presents a new range of power supplies especially designed for the automation market. The wide range of supply voltages and DC output voltages/power provide a multitude of choices for all low power electrical or electronic devices commonly used in automatic machinery. Components such as sensors, electromechanical relays, contactors, solid state relays, timers, temperature controllers, PLCs, process controllers, DC motors, solenoids, displays, etc. now have a reliable power source.



Space Optimization



Diagnostic Warning



User Friendly



Minimizing Energy Cost



Long Term Reliability



Long Term Reliability

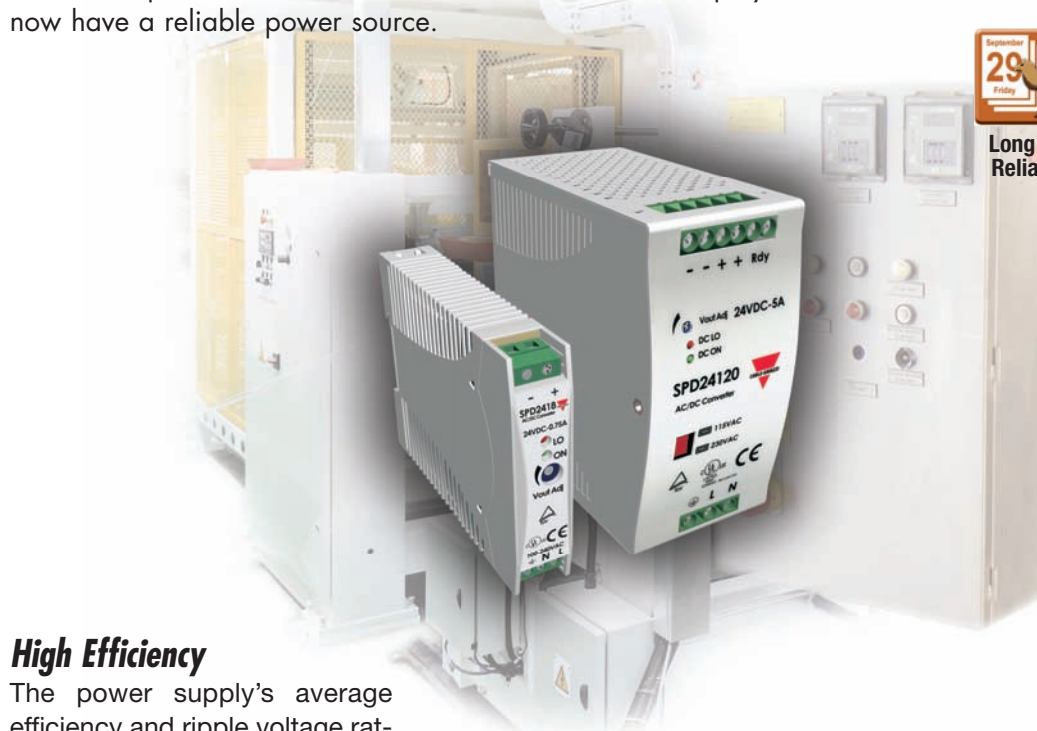

High Efficiency

The power supply's average efficiency and ripple voltage ratings are comparable or better than most power supplies on the market.

Product Range

	5V	12V	15V	24V	48V
SPD 5-10-18W	■	■	■	■	
SPD 30-60W	■	■		■	■
SPD 120W		■		■	■
SPD 240-480W				■	■

Adjustable Output

All models provide a front potentiometer in order to adjust the output voltage. This useful feature can provide a voltage surplus when line voltage losses cause low voltages to the load.

Parallel Connection

Parallel connection is a standard feature with the 240W and 480W versions, and optional on the 120W version.

Visual and Electrical Indications

Models up to 18W are equipped with two front LEDs, which provide a visual indication of the 'Power Out' enabled and 'Low Voltage' on the output. All other sizes are equipped with an LED indication and also with an output 'Power Ready' signal. This signal could be used by other electronic devices or to power an alarm (this feature is only available on 24VDC output versions).

Power Factor Correction (PFC)

The PFC function is a standard feature on the 240W and 480W models and available upon request on the 120W model.

Approvals and Warranty

All SPD Power Supplies are approved according to UL, cUL, TUV and CE safety standards: UL class 2 recognized and Class B for the emissions according to European standards. They are also RoHS compliant. All models feature a Two Year Warranty.



Specifications are subject to change without notice.



Ventilation Grid

Output Terminals

Also available with spring connectors.

Model Number

'LO' LED

Indicates output voltage too low.

'ON' LED

Indicates power output is OK.

Safety Label

Approval data file numbers EAN cod and traceability data.

DIN Rail Clip

Easy installation on any kind of DIN Rail.

Input Terminals

Also available with spring or screw connectors.



TRIMMER and STATUS LEDs

An adjustment trimmer pot is featured on all the models throughout the range. It allows a fine regulation of the output with the two 'status LEDs', therefore the information about correct operation of power supply is available at a glance. All models, except the 30W and 60W, feature two LEDs: one for power output (ON) and one for indication of low voltage on output (LO).

SPD 5, 10 and 18W

- 5, 10 and 18W Switching Power Supplies
- 22.5mm wide, plastic enclosure
- DIN rail mounting
- Screw terminal or spring terminal connections
- Input voltage: 90-265VAC or 120-370VDC
- Available output voltages: 5, 12, 15 or 24 VDC
- Output voltage adjustment
- Internal noise filter
- Short circuit protection
- Front indication of power 'OK' and 'Low Voltage' output
- Operating temperature without derating: -10° to +60°C



Switching Power Supplies



Part Number	Description	Vin *VAC	Vout VDC	Iout A
SPD 05 05 I	Switching Power Supply 5W, DIN Rail	100 - 240	5	1
SPD 05 05 IB	Switching Power Supply 5W, DIN Rail Spring terminals	100 - 240	5	1
SPD 12 05 I	Switching Power Supply 5W, DIN Rail	100 - 240	12	0.42
SPD 12 05 I B	Switching Power Supply 5W, DIN Rail, Spring terminals	100 - 240	12	0.42
SPD 15 05 I	Switching Power Supply 5W, DIN Rail	100 - 240	15	0.34
SPD 15 05 I B	Switching Power Supply 5W, DIN Rail, Spring terminals	100 - 240	15	0.34
SPD 24 05 I	Switching Power Supply 5W, DIN Rail	100 - 240	24	0.21
SPD 24 05 I B	Switching Power Supply 5W, DIN Rail, Spring terminals	100 - 240	24	0.21
SPD 05 10 I	Switching Power Supply 10W, DIN Rail	100 - 240	5	2
SPD 05 10 I B	Switching Power Supply 10W, DIN Rail, Spring terminals	100 - 240	5	2
SPD 12 10 I	Switching Power Supply 10W, DIN Rail	100 - 240	12	0.84
SPD 12 10 I B	Switching Power Supply 10W, DIN Rail, Spring terminals	100 - 240	12	0.84
SPD 15 10 I	Switching Power Supply 10W, DIN Rail	100 - 240	15	0.67
SPD 15 10 I B	Switching Power Supply 10W, DIN Rail, Spring terminals	100 - 240	15	0.67
SPD 24 10 I	Switching Power Supply 10W, DIN Rail	100 - 240	24	0.42
SPD 24 10 I B	Switching Power Supply 10W, DIN Rail, Spring terminals	100 - 240	24	0.42
SPD 05 18 I	Switching Power Supply 15W, DIN Rail	100 - 240	5	3
SPD 05 18 I B	Switching Power Supply 15W, DIN Rail, Spring terminals	100 - 240	5	3
SPD 12 18 I	Switching Power Supply 18W, DIN Rail	100 - 240	12	1.5
SPD 12 18 I B	Switching Power Supply 18W, DIN Rail, Spring terminals	100 - 240	12	1.5
SPD 15 18 I	Switching Power Supply 18W, DIN Rail	100 - 240	15	1.2
SPD 15 18 I B	Switching Power Supply 18W, DIN Rail, Spring terminals	100 - 240	15	1.2
SPD 24 18 I	Switching Power Supply 18W, DIN Rail	100 - 240	24	0.75
SPD 24 18 I B	Switching Power Supply 18W, DIN Rail, Spring terminals	100 - 240	24	0.75
SPD 05 30 I	Switching Power Supply 30W, DIN Rail	100 - 240	5	6
SPD 05 30 I B	Switching Power Supply 30W, DIN Rail, Spring terminals	100 - 240	5	6
SPD 12 30 I	Switching Power Supply 30W, DIN Rail	100 - 240	12	2.5
SPD 12 30 I B	Switching Power Supply 30W, DIN Rail, Spring terminals	100 - 240	12	2.5
SPD 24 30 I	Switching Power Supply 30W, DIN Rail,	100 - 240	24	1.25
SPD 24 30 I B	Switching Power Supply 30W, DIN Rail, Spring terminals	100 - 240	24	1.25
SPD 48 30 I	Switching Power Supply 30W, DIN Rail,	100 - 240	48	0.625
SPD 48 30 I B	Switching Power Supply 30W, DIN Rail, Spring terminals	100 - 240	48	0.625
SPD 05 60 I	Switching Power Supply 50W, DIN Rail	100 - 240	5	10
SPD 05 60 I B	Switching Power Supply 50W, DIN Rail, Spring terminals	100 - 240	5	10
SPD 12 60 I	Switching Power Supply 60W, DIN Rail	100 - 240	12	5
SPD 12 60 I B	Switching Power Supply 60W, DIN Rail, Spring terminals	100 - 240	12	5
SPD 24 60 I	Switching Power Supply 60W, DIN Rail	100 - 240	24	2.5
SPD 24 60 I B	Switching Power Supply 60W, DIN Rail, Spring terminals	100 - 240	24	2.5
SPD 48 60 I	Switching Power Supply 60W, DIN Rail	100 - 240	48	1.25
SPD 48 60 I B	Switching Power Supply 60W, DIN Rail, Spring terminals	100 - 240	48	1.25
SPD 12 120 I	Switching Power Supply 120W, DIN Rail	100 - 240	12	10
SPD 12 120 I F	Switching Power Supply 120W, DIN Rail, with PFC	100 - 240 with PFC	12	10
SPD 12 120 I P	Switching Power Supply 120W, DIN Rail, with Parallel function	100 - 240	12	10
SPD 12 120 I FP	Switching Power Supply 120W, DIN Rail, with PFC and Parallel function	100 - 240	12	10

Part Number	Description	Vin *VAC	Vout VDC	Iout A
SPD 12 120 I B	Switching Power Supply 120W, DIN Rail, Removable connectors	100 - 240	12	10
SPD 12 120 I BF	Switching Power Supply 120W, DIN Rail, Removable connectors and PFC	100 - 240	12	10
SPD 12 120 I BP	Switching Power Supply 120W, DIN Rail, Removable connectors and Parallel function	100 - 240	12	10
SPD 12 120 I BFP	Switching Power Supply 120W, DIN Rail, Removable connectors, PFC and Parallel function	100 - 240	12	10
SPD 24 120 I	Switching Power Supply 120W, DIN Rail	100 - 240	24	5
SPD 24 120 I F	Switching Power Supply 120W, DIN Rail,	100 - 240 with PFC	24	5
SPD 24 120 I P	Switching Power Supply 120W, DIN Rail, with Parallel function	100 - 240	24	5
SPD 24 120 I FP	Switching Power Supply 120W, DIN Rail, with PFC and Parallel function	100 - 240	24	5
SPD 24 120 I B	Switching Power Supply 120W, DIN Rail, Removable connectors	100 - 240	24	5
SPD 24 120 I BF	Switching Power Supply 120W, DIN Rail, Removable connectors and PFC	100 - 240	24	5
SPD 24 120 I BP	Switching Power Supply 120W, DIN Rail, Removable connectors and Parallel function	100 - 240	24	5
SPD 24 120 I BFP	Switching Power Supply 120W, DIN Rail, Removable connectors, PFC and Parallel function	100 - 240	24	5
SPD 48 120 I	Switching Power Supply 120W, DIN Rail	100 - 240	48	2.5
SPD 48 120 I F	Switching Power Supply 120W, DIN Rail,	100 - 240 with PFC	48	2.5
SPD 48 120 I P	Switching Power Supply 120W, DIN Rail, with Parallel function	100 - 240	48	2.5
SPD 48 120 I FP	Switching Power Supply 120W, DIN Rail, with PFC and Parallel function	100 - 240	48	2.5
SPD 48 120 I B	Switching Power Supply 120W, DIN Rail, Removable connectors	100 - 240	48	2.5
SPD 48 120 I BF	Switching Power Supply 120W, DIN Rail, Removable connectors and PFC,	100 - 240	48	2.5
SPD 48 120 I BP	Switching Power Supply 120W, DIN Rail, Removable connectors and Parallel function,	100 - 240	48	2.5
SPD 48 120 I BFP	Switching Power Supply 120W, DIN Rail, Removable connectors, PFC and Parallel function	100 - 240	48	2.5
SPD 24 240 I	Switching Power Supply 240W, DIN Rail, PFC and Parallel function	100 - 240	24	10
SPD 24 240 I B	Switching Power Supply 240W, DIN Rail, Removable connectors, PFC and Parallel function	100 - 240	24	10
SPD 48 240 I	Switching Power Supply 240W, DIN Rail, PFC and Parallel function	100 - 240	48	5
SPD 48 240 I B	Switching Power Supply 240W, DIN Rail, Removable connectors, PFC and Parallel function	100 - 240	48	5
SPD 24 480 I	Switching Power Supply 480W, DIN Rail, PFC and Parallel function	100 - 240	24	20
SPD 24 480 IB	Switching Power Supply 480W, DIN Rail, Removable connector, PFC and Parallel function	100 - 240	24	20
SPD 48 480 I	Switching Power Supply 480W, DIN Rail, PFC and Parallel function	100 - 240	48	10
SPD 48 480 IB	Switching Power Supply 480W, DIN Rail, Removable connector, PFC and Parallel function	100 - 240	48	10

* Approximate AC supply voltage is 100-240VAC. However, they can also be powered by lower and higher AC voltages and also DC Voltages. See datasheet for more accurate specifications.