

# Mist Separator Series AFM20/30/40

## Flow Characteristics (Representative values)

— : When saturated with oil  
 - - - : Initial state

### AFM20

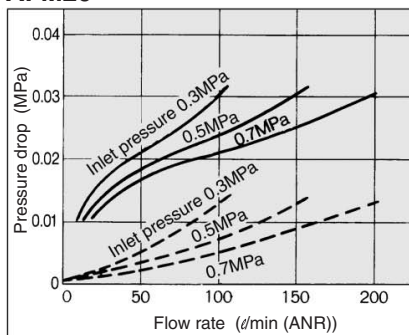

### AFM30

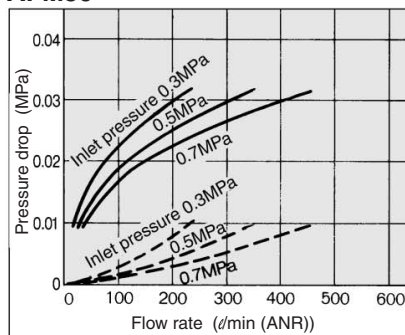

### AFM40

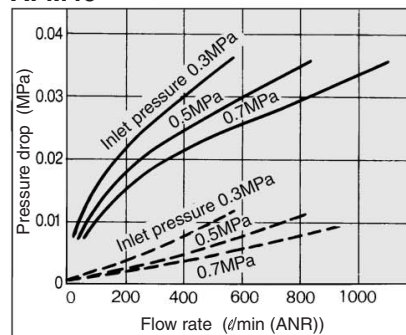

## Construction

### AFM20

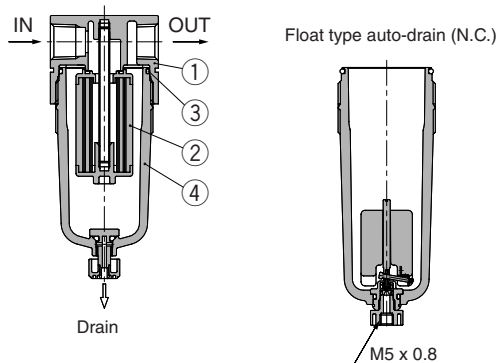

### AFM30/40

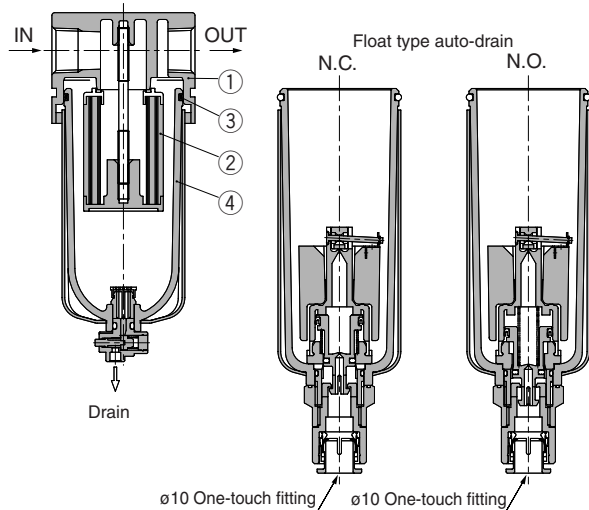

## Component Parts

No.	Description	Material		Note
		AFM20	AFM30, AFM40, AFM40-06	
①	Body	Zinc die-casted	Aluminum die-casted	Platinum silver

## Replacement Parts

No.	Description	Material	Part no.			
			AFM20	AFM30	AFM40	AFM40-06
②	Element assembly	—	AFM20P-060AS	AFM30P-060AS	AFM40P-060AS	AFM40P-060AS
③	Bowl O-ring	NBR	C2SFP-260S	C3SFP-260S	C4SFP-260S	C4SFP-260S
④	Bowl assembly (1)	PC	C2SF	C3SF (2)	C4SF (2)	C4SF (2)

Note 1) Including O-Ring. Please contact SMC regarding the bowl assembly supply for PSI and °F unit specifications.  
 Note 2) Bowl assembly for AFM30 to AFM40-06 includes a bowl guard (steel band material).

## ⚠ Precautions

Be sure to read before handling. Refer to pages 14-21-3 to 14-21-4 for Safety Instructions and Common Precautions.

### Air Supply

## ⚠ Caution

1. Install an air filter (Series AF) as a preliminary filter on the inlet side of the mist separator to prevent premature clogging.
2. Do not install on the inlet side of the dryer as this can cause premature clogging of the element.

### Maintenance

## ⚠ Warning

1. Replace the element every 2 years or when the pressure drop becomes 0.1 MPa, whichever comes first, to prevent damage to the element.

### Design

## ⚠ Caution

1. Design the system so that the mist separator is installed in a pulsation-free location. The difference between internal and external pressure inside the element should be kept within 0.1 MPa, as exceeding this value could cause damage.

### Selection

## ⚠ Caution

1. Do not allow air flow that exceeds the rated flow. If the air flow is allowed outside the range of the rated flow even momentarily, drainage and lubricant may splash at the outlet side or cause damage to the component.
2. Do not use in a low pressure application (such as a blower). F.R.L. unit has its own minimum operating pressure depending on the equipment and is designed specifically to function with compressed air. If used below the minimum operating pressure, a loss of performance and malfunction can occur. Please contact SMC if an application under such conditions cannot be avoided.

F.R.L.

AV

AU

AF

AR

IR

VEX

AMR

ITV

IC

VBA

VE□

VY1

G

PPA

AL