

Type: 3120-F



Switch/thermal trip free circuit breaker (S-type TO CBE to EN 60934) with standard isolator style two button operation. Single button press-to-reset version also available. Both types can be supplied in single pole configuration only, in double pole with single pole protection, and in double pole with protection on both poles. Designed for snap-in panel mounting. There is a choice of push button colour combinations and illumination is optional.

Any one of the following additional function modules can be supplied factory fitted to the rear of the switch/circuit breaker:

- Undervoltage release coil (for double pole versions only).
- Magnetic trip coil for short circuit protection.
- Magnetic trip coil for remote relay trip.
- Auxiliary contacts for status signalling.
- Mechanical slide interlock.

Approved to CBE standard EN 60934 (IEC 60934).

Dimensions

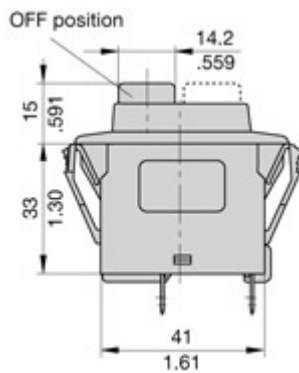

Internal connection diagrams

2 pole
thermally protected

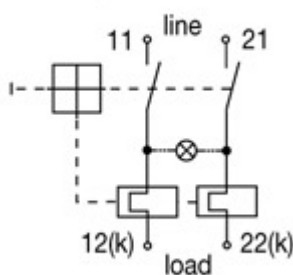

Voltage rating:

- AC 240 V (AC 415 V to special order)
- DC 50 V
- UL/CSA: AC 250 V

Current ratings:

from 0.1 A to 20 A
(up to 30 A to special order, single pole only)

Number of poles:

single pole
double pole

Mounting method:

flange

Terminal design:

blade terminals
screw terminals

Actuation:

push button

Auxiliary contacts:

with auxiliary contacts
without auxiliary contacts

Water splash protection:

with water splash protection
without water splash protection

Illumination:

with illumination
without illumination

Typical life:

0.1...16 A 50,000 operations at $1 \times I_N$, inductive, double pole

0.1...20 A 30,000 operations at $1 \times I_N$, inductive, single pole

Interrupting capacity I_{cn} :

0.1...2 A: $10 \times I_N$

2.5...20 A: 150 A single pole

2.5...20 A: 250 A double pole

Approvals:

VDE, CSA, UL, CCC

Description

An extremely versatile range of rocker switch/thermal circuit breakers (S-type TO CBE to EN 60934 with trip free mechanism) offering the choice of single pole, double pole with single pole protection, and double pole with protection on both poles. Designed for snap-in panel mounting with versions available for three different panel cut-out sizes. Illumination is optional and there is a range of colours and markings for the rocker. Under overload conditions the rocker returns to the OFF position. 6-way frame for 3120-F5 available upon request.

Any one of the following additional function modules can be supplied factory fitted to the rear of the switch/circuit breaker.

- Under voltage release coil (for double pole versions only).
- Magnetic trip coil for short circuit protection.
- Magnetic trip coil for remote relay trip.
- Auxiliary contacts for status signalling.
- Mechanical slide interlock.

Approved to CBE standard EN 60934 (IEC 60934).

Typical applications

Motors, transformers, solenoids, extra low voltage wiring systems, office machines, electro-medical equipment, power supplies, communications systems, medical equipment to EN 60601.

Standard current ratings and typical internal resistance values

Current rating (A)	Internal resistance per pole (Ω)	Current rating (A)	Internal resistance per pole (Ω)
0.1	94	3.5	0.0565
0.2	24	4	0.0435
0.3	12	4.5	0.0435
0.4	5.30	5	0.0325
0.5	4.20	6	0.0215
0.6	2.90	7	0.0165
0.8	1.50	8	0.0165
1	0.9	10	< 0.02
1.2	0.80	12	< 0.02
1.5	0.45	14	< 0.02
2	0.27	16	< 0.02
2.5	0.0785	18	< 0.02
3	0.0595	20	< 0.02

Illumination voltage/power consumption

operating voltage	power consumption	
	filament/neon	LED
6 V	60 mA	9 mA
12 V	20 mA	9 mA
24 V	20 mA	9 mA
48 V	20 mA	1.5 mA
115 V	< 1.5 mA	< 1 mA*
230 V	< 1.5 mA	< 1 mA*

* single pole version only

Approvals

Authority	Voltage ratings	Current ratings
VDE (EN 60934)	AC 240 V; DC 28 V DC 50 V DC 50 V	0.1...20 A 0.1...20 A 2-pole 0.1...10 A 1-pole
UL, CSA	AC 250 V; DC 50 V	0.1...20 A
CCC	AC 250 V; DC 50 V	0.1...20 A



3120-F...

Technical data

For further details please see chapter: Technical Information

Voltage rating	AC 240 V; DC 50 V (AC 415 V to special order) (UL: AC 250 V; DC 50 V)		
Current ratings	0.1...20 A (up to 30 A to special order, single pole only)		
Typical life	1-pole		
	AC 240 V:	0.1...20 A	30,000 operations at 1 x I_N , inductive
DC 50 V:	0.1...4 A	30,000 operations at 1 x I_N , inductive	
	4.5...16 A	30,000 operations at 1 x I_N , resistive	
DC 28 V:	4.5...20 A	30,000 operations at 1 x I_N , inductive	
	2-pole		
AC 415 V:	0.1...16 A	10,000 operations at 1 x I_N , inductive	
	0.1...16 A	50,000 operations at 1 x I_N , inductive	
AC 240 V:	17...20 A	30,000 operations at 1 x I_N , inductive	
	0.1...16 A	50,000 operations at 1 x I_N , inductive	
DC 50 V:	17...20 A	10,000 operations at 1 x I_N , inductive	
	Ambient temperature		
-30...+60 °C (-22...+140 °F)			
Insulation co-ordination (IEC 60664 and 60664 A)	rated impulse withstand voltage	pollution degree	
	2.5 kV	2	reinforced insulation in operating area
Dielectric strength (IEC 60664 and 60664A)	test voltage		
	operating area	AC 3,000 V	
between poles (2-pole)	AC 1,500 V		
Insulation resistance	> 100 M Ω (DC 500 V)		
Interrupting capacity I_{cn}	0.1...2 A	10 x I_N	
	2.5...20 A	250 A 2-pole, or 150 A 1-pole	
Interrupting capacity (UL 1077)	I_N	U_N	2-pole
	0.1...2 A	AC 250 V	200 A
	2.5...3 A	AC 250 V	1,000 A
	3.5...8 A	AC 250 V	2,000 A
	9...16 A	AC 250 V	3,500 A
	18...20 A	AC 250 V	5,000 A
0.1...20 A	DC 50 V	1,000 A	
Degree of protection (IEC 60529/DIN 40050)	operating area IP40		
	(IP54 with water splash protection) terminal area IP00		
Vibration	8 g (57-500 Hz), \pm 0.61 mm (10-57 Hz) to IEC 60068-2-6, test Fc 10 frequency cycles/axis		
Shock	30 g (11 ms) to IEC 60068-2-27, test Ea		
Corrosion	96 hours at 5 % salt mist, to IEC 60068-2-11, test Ka		
Humidity	240 hours at 95 % RH, to IEC 60068-2-3, test Ca		
Mass	approx. 33 g (double pole)		
	approx. 27 g (single pole)		

Ordering information

Type No.																																									
3120	rocker switch/circuit breaker																																								
Mounting																																									
F	snap in frame																																								
Size of frame																																									
panel thickness																																									
3	to fit mounting cut-out 50.5 x 21.5 mm 1-6.35 mm (.039-.250 in)																																								
5	to fit mounting cut-out 44.5 x 22 mm 1-4 mm (.039-.157 in)																																								
6	to fit mounting cut-out 45 x 33.7 mm 1.2-2.4 mm (.047-.094 in)																																								
Number of poles																																									
0	2-pole, unprotected, switch only																																								
1	1-pole, thermally protected																																								
2	2-pole, thermally protected																																								
5	2-pole, thermally protected on one pole only (terminals 11,12k,12)																																								
6	1-pole, unprotected, switch only																																								
Mounting frame design																																									
1	collar height 1 mm																																								
3	collar height 9 mm																																								
4	collar height 2 mm with water splash protection (IP54), not with -F6...																																								
U	with water splash protection and actuator guard																																								
Terminal configuration																																									
P7	blade terminals 2x2.8x0.8 mm (QC 2x.110) (terminals 12(k), 22(k), 11, 21), not for under voltage module, not for switch																																								
H7	12(k), 22(k): blade terminals 2x2.8-0.8 (QC 2x.110) 11, 21: terminal screws, not for switch																																								
N7	as P7, but including shunt terminals 12(i) and 22(i) as blade terminals 2x2.8x0.8 mm (QC 2x.110) not for under voltage module																																								
G7	as H7, but including shunt terminals 12(i) and 22(i) as blade terminals 2x2.8x0.8 mm (QC 2x.110)																																								
Characteristic curve																																									
T1	thermal, 1.01-1.4 x I _N																																								
Q1	switch only																																								
Actuator style																																									
W	rocker																																								
U	momentary switch																																								
Switch colour designation																																									
opaque	translucent (for illuminated versions)																																								
01 black	12 white																																								
02 white	14 red																																								
04 red	15 orange																																								
	19 green																																								
Rocker markings																																									
A	<table border="1"> <tr> <td>0</td> <td>AUS OFF</td> <td></td> <td></td> <td></td> <td></td> <td></td> <td></td> <td></td> <td></td> </tr> <tr> <td></td> <td></td> <td>I</td> <td>EIN ON</td> <td></td> <td></td> <td></td> <td></td> <td></td> <td></td> </tr> <tr> <td></td> <td></td> <td></td> <td></td> <td>0</td> <td>AUS OFF</td> <td></td> <td></td> <td></td> <td></td> </tr> <tr> <td></td> <td></td> <td>I</td> <td>EIN ON</td> <td></td> <td></td> <td></td> <td></td> <td></td> <td></td> </tr> </table>	0	AUS OFF											I	EIN ON											0	AUS OFF							I	EIN ON						
0		AUS OFF																																							
			I	EIN ON																																					
					0	AUS OFF																																			
			I	EIN ON																																					
B																																									
C																																									
D																																									
E																																									
F																																									
X																																									
	X = without marking																																								
Rocker illumination (optional)																																									
B	filament ≤ 48 V AC/DC; neon ≥ 115 V AC																																								
G	green LED, AC/DC																																								
Y	yellow LED, AC/DC																																								
R	red LED, AC/DC																																								
Illumination voltage range																																									
0	4 - 7 V (B,G,Y,R)																																								
1	10 - 14 V (B,G,Y,R)																																								
2	20 - 28 V (B,G,Y,R)																																								
3	90 - 140 V (B)																																								
4	185 - 275 V (B)																																								
5	42 - 54 V (B,Y,R)																																								
Current ratings																																									
0.1...20 A																																									

3120 - F 3 2 1 - N7 T1 - W 14 A B 4 - 10 A ordering example
 3120 - F . 0 . - N7 Q1 - W - 20 A (switch only)

N.B.
 Switch only versions must be specified with -N7 or -G7 terminals.
 Terminals 12(k) and 22(k) are not fitted.

Typical time/current characteristics

single or double pole load

0.1 ... 2 A

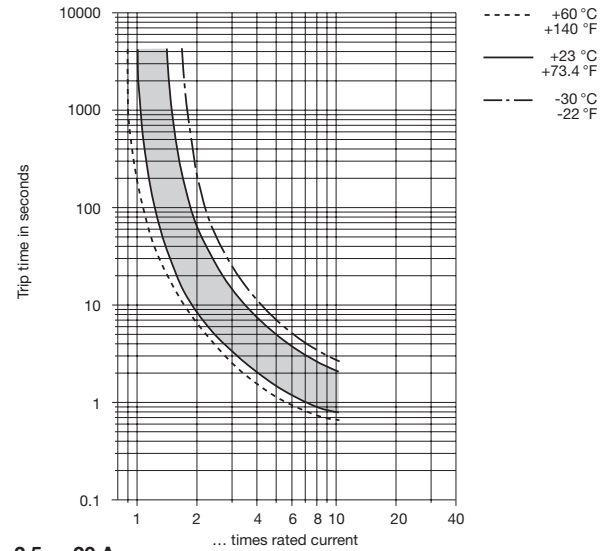

2.5 ... 20 A

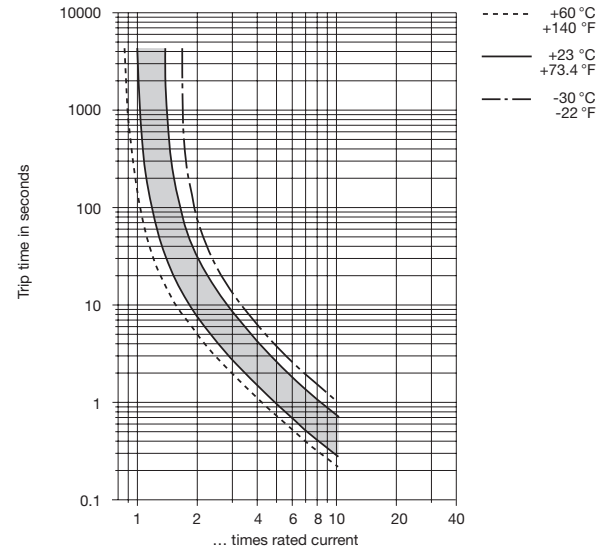

The time/current characteristic curve depends on the ambient temperature prevailing. In order to eliminate nuisance tripping, please multiply the circuit breaker current ratings by the derating factor shown below. See also section 9 – Technical information.

Ambient temperature °F	-22	-4	+14	+32	+73.4	+104	+122	+140
°C	-30	-20	-10	0	+23	+40	+50	+60
Derating factor	0.8	0.76	0.84	0.92	1	1.08	1.16	1.24

Internal connection diagrams

2-pole, thermally protected on both poles

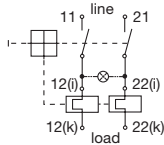

2-pole, thermally protected on one pole only

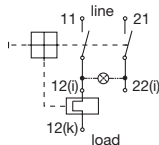

1-pole, thermally protected

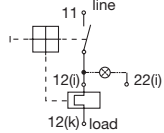

2-pole, unprotected

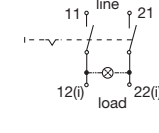

Dimensions

Style F3.1
collar height 1 mm/.039 in.

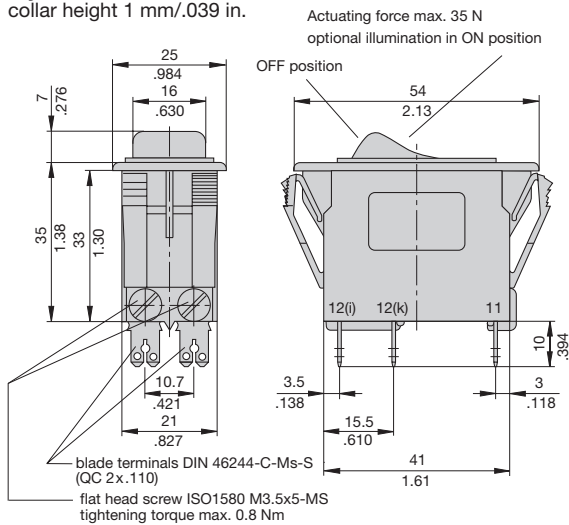

Installation drawing

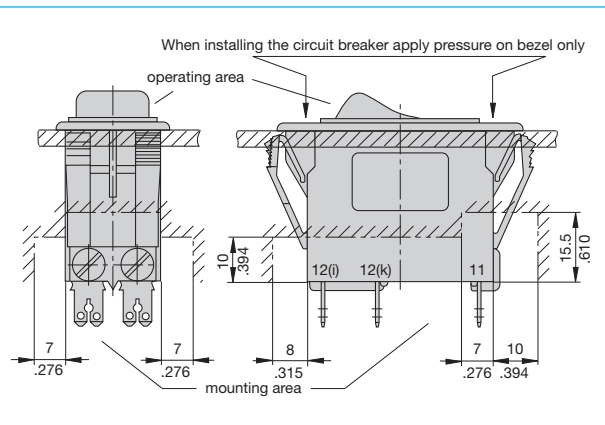

This is a metric design and millimeter dimensions take precedence ($\frac{\text{mm}}{\text{inch}}$)

Mounting style variants

Style F 3.3 collar height 9 mm (.354 in.)

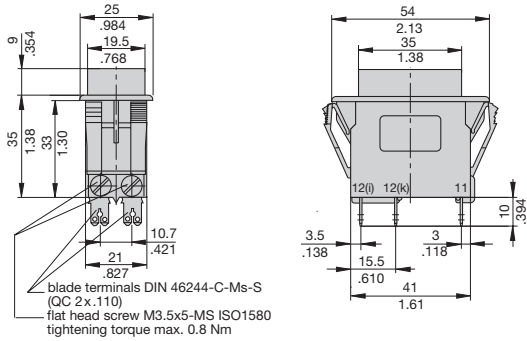

Style F 3.4
collar height 2 mm (.079 in.), with water splash protection

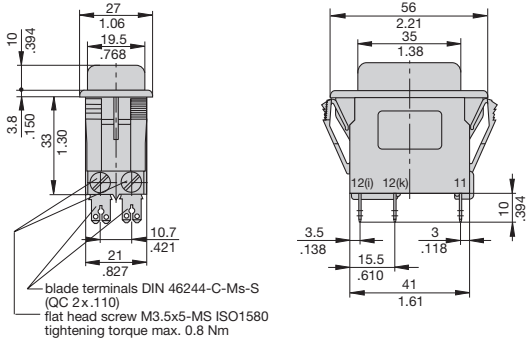

Style F 5.1

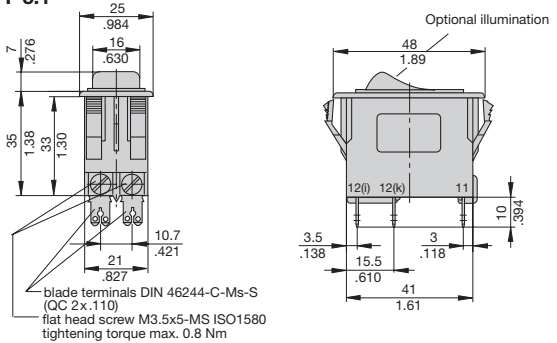

Style F 5.U
with water splash protection (IP54) and actuator guard

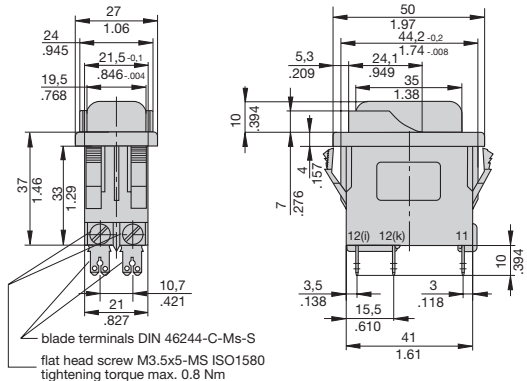

Dimension diagram for style F6 is available on request.