

# Snap-action Microswitches – Miniature XG

## XG

- Characteristics
- Wide number of force variants
  - High mechanical and electrical life
  - Solder terminals
  - Quick connect
  - PCB terminals
  - High temperature versions
  - Wide range of levers

Rating 250 VAC, 26 A

Dimensions (mm) 27.8 x 15.9 x 10.3

Actuator Plunger, plain levers, roller levers, simulated (cam follower) roller lever

Approvals UL, cUL, CSA, ENEC



## Preferred Product Range

Ordering Reference	Actuating Force		Operating position		Terminal	Circuit	Actuator	Contacts	Electrical rating ENEC	UL
	(N)	(oz)	(mm)	(in)						
XGG2-88Z1	3.20	11.43	14.7	0.57	Faston	CO	Plunger	Ag / AgNi10	16(6) A	15 A
XGG2-88-J23Z1	1.40	5.03	14.9	0.59	Faston	CO	Plain lever	Ag / AgNi10	16(6) A	15 A
XGG2-88-J26Z1	0.91	3.27	14.5	0.57	Faston	CO	Plain lever	Ag / AgNi10	16(6) A	15 A
XGG2-88-J27Z1	0.65	2.34	13.7	0.54	Faston	CO	Plain lever	Ag / AgNi10	16(6) A	15 A
XGG2-88-S20Z1	3.20	11.43	20.2	0.79	Faston	CO	Roller lever	Ag / AgNi10	16(6) A	15 A
XGG2-88-S21Z1	1.55	5.57	20.1	0.79	Faston	CO	Roller lever	Ag / AgNi10	16(6) A	15 A
XGG3-88Z1	3.20	11.43	14.7	0.57	Solder	CO	Plunger	Ag / AgNi10	16(6) A	15 A
XGG6-88Z1	3.20	11.43	14.7	0.57	Faston	CO	Plunger	Ag / AgNi10	16(6) A	15 A
XGC2-88Z1	0.80	2.86	14.7	0.57	Faston	CO	Plunger	Ag / AgNi10	12(6) A	10 A
XGC2-88-J23Z1	0.35	1.26	15.0	0.59	Faston	CO	Plain lever	Ag / AgNi10	12(6) A	10 A
XGC2-88-S20Z1	0.80	2.86	20.2	0.79	Faston	CO	Roller lever	Ag / AgNi10	12(6) A	10 A
XGC6-88Z1	0.80	2.86	14.7	0.57	Faston	CO	Plunger	Ag / AgNi10	12(6) A	10 A
XGK2-88Z1	1.50	5.36	14.7	0.57	Faston	CO	Plunger	Ag / AgNi10	12(6) A	12 A
XGK2-88-J26Z1	0.43	1.55	14.7	0.57	Faston	CO	Plain lever	Ag / AgNi10	12(6) A	12 A
XGK2-88-S21Z1	0.71	2.55	20.2	0.80	Faston	CO	Roller lever	Ag / AgNi10	12(6) A	12 A
XGK3-88Z1	1.50	5.36	14.7	0.57	Solder	CO	Plunger	Ag / AgNi10	12(6) A	12 A
XGK6-88Z1	1.50	5.36	14.7	0.57	Faston	CO	Plunger	Ag / AgNi10	12(6) A	12 A
XG02-88Z1	1.20	4.29	14.5	0.57	Faston	CO	Plunger	Ag / AgNi10	16(6) A	15 A
XG02-88-J27Z1	0.25	0.90	13.6	0.54	Faston	CO	Plain lever	Ag / AgNi10	16(6) A	15 A
XG02-88-S20Z1	1.20	4.29	20.1	0.79	Faston	CO	Roller lever	Ag / AgNi10	16(6) A	15 A
XG06-88Z1	1.20	4.29	14.5	0.57	Faston	CO	Plunger	Ag / AgNi10	16(6) A	15 A

# Snap-action Microswitches – Miniature XG

## Specifications

Housing	Phenolic-Melamine, thermosetting
Plunger	POM for T85, PBT for T150
Mechanism	Heat-treated spring made from beryllium bronze, 4 parallel current path, high contact pressure
Functions	Change-over, normally-closed (except XGG and XGK) or normally-open
Contacts	Fine silver (Ag), silver nickel (AgNi10), gold-plated 4 μm (Au), silver cadmium oxide (AgCdO)
Terminals	Solder faston, screw, PCB and side mounting PCB terminals. RAST 5 terminals, 5.0 mm pitch
Temperature range °C	-40° C to +150° C
Mechanical life	2.5 · 10 <sup>5</sup> cycles minimum, 50 · 10 <sup>6</sup> cycles maximum (Actuation: sinusoidal and maximum up to 80% of the overtravel)
Protection	Enclosure IP40
Mounting	Side mounting via mounting holes
Actuators	Stainless steel

Circuit diagram

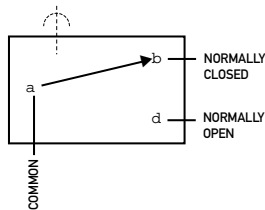

Dimensions (mm)

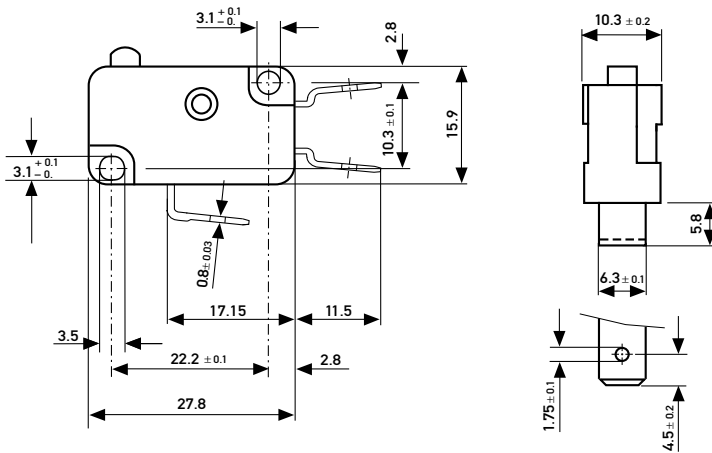

## Recommended Maximum Electrical Ratings

	Voltage (VAC)	Approvals ENEC	UL	(VAC)	Voltage (VAC)	Resistive load (A)	Motor load (A)	UL
XGG...-88	250	16 (6) 5E4	15 A	125/250 VAC	XGT...-86	250	26	10 25 A 2 HP
XGA...-88	250	16 (6) 5E4	15 A	125/250 VAC	XGD...-86	250	22	6 21 A 2 HP
XGM...-88	250	16 (6) 5E4	15 A	125/250 VAC	XGA...-86	250	20	8 15 A 1/2 HP
XGO...-88	250	16 (6) 5E4	15 A	125/250 VAC	XGM...-86	250	20	8 15 A 1/2 HP
XGB...-88	250	12 (6) 5E4	10 A	125/250 VAC	XGO...-86	250	20	8 15 A 1/2 HP
XGC...-88	250	12 (6) 5E4	10 A	125/250 VAC	XGA...-86	400	10	6
XGH...-88	250	12 (6) 5E4	10 A	125/250 VAC	XGG...-86	400	10	6
XGK...-88	250	12 (6) 5E4	10 A	125/250 VAC	XGM...-86	400	10	6
XG...-88	400	3 2			XGO...-86	400	10	6
					XGT...-86	400	10	10

# Snap-action Microswitches – Miniature XG

## Operating Characteristics

Actuator	Reference	Actuating Force		Release Force		Free Position		Operating Position		Movement Differential		Total travelled position		
		Maximum (N)	(oz)	Minimum (N)	(oz)	Maximum (mm)	(in)	(mm)	(in)	Maximum (mm)	(in)	Maximum (mm)	(in)	
Plunger (mm) 	XGG..	3.2	11.43	0.4	1.43	15.75	0.62	14.7	0.57	0.35	0.013	13.2	0.519	
	XGA..	3.2	11.43	0.6	2.14	15.75	0.62	14.7	0.57	0.15	0.006	13.2	0.519	
	XGM..	2	7.14	0.5	1.79	15.6	0.61	14.5	0.57	0.35	0.013	13.7	0.539	
	XGO..	1.2	4.29	0.1	0.36	15.6	0.61	14.5	0.57	0.35	0.013	13.7	0.539	
	XGK..	1.5	5.36	0.2	0.71	15.75	0.62	14.7	$+0.2$ $-0.4$	$+0.007$ $-0.015$	0.35	0.013	13.2	0.519
	XGB..	1.5	5.36	0.3	1.07	15.75	0.62	14.7	0.57	0.15	0.006	13.2	0.519	
	XGC..	0.8	2.86	0.1	0.36	15.75	0.62	14.7	0.57	0.15	0.006	13.2	0.519	
	XGD..	0.45	1.61	0.05	0.18	15.6	0.61	14.5	0.57	0.35	0.013	13.7	0.539	
	XGH..	1.7	6.07	0.15	0.54	15.75	0.62	14.7	0.57	0.15	0.006	13.2	0.519	
-J20 Lever (mm) 	XGG..	3.2	11.43	0.36	1.29	16.5	0.64	$15.1 \pm 0.5$	$0.59 \pm 0.019$	0.4	0.015	14	0.551	
	XGA..	3.2	11.43	0.54	1.93	16.5	0.64	$15.1 \pm 0.5$	$0.59 \pm 0.019$	0.2	0.007	14	0.551	
	XGM..	2	7.14	0.45	1.61	16.5	0.64	$15 \pm 0.5$	$0.59 \pm 0.019$	0.4	0.015	14.4	0.566	
	XGO..	1.2	4.29	0.09	0.34	16.5	0.64	$15 \pm 0.5$	$0.59 \pm 0.019$	0.4	0.015	14.4	0.566	
	XGK..	1.5	5.36	0.18	0.64	16.5	0.64	$15.1 \pm 0.5$	$0.59 \pm 0.019$	0.4	0.015	14	0.551	
	XGB..	1.5	5.36	0.27	0.96	16.5	0.64	$15.1 \pm 0.5$	$0.59 \pm 0.019$	0.2	0.007	14	0.551	
	XGC..	0.8	2.86	0.09	0.32	16.5	0.64	$15.1 \pm 0.5$	$0.59 \pm 0.019$	0.2	0.007	14	0.551	
	XGH..	0.45	1.61	0.04	0.14	16.5	0.64	$15 \pm 0.5$	$0.59 \pm 0.019$	0.4	0.015	14.4	0.566	
-M20 Lever (mm) 	XGG..	2.6	9.29	0.32	1.14	19.2	0.75	$17.5 \pm 0.7$	$0.68 \pm 0.027$	0.45	0.017	16.4	0.645	
	XGA..	2.6	9.29	0.48	1.71	19.2	0.75	$17.5 \pm 0.7$	$0.68 \pm 0.027$	0.2	0.007	16.4	0.645	
	XGM..	1.65	5.89	0.4	1.43	19.2	0.75	$17.3 \pm 0.7$	$0.68 \pm 0.027$	0.45	0.017	16.9	0.665	
	XGO..	1	3.57	0.08	0.29	19.2	0.75	$17.3 \pm 0.7$	$0.68 \pm 0.027$	0.45	0.017	16.9	0.665	
	XGK..	1.25	4.46	0.16	0.57	19.2	0.75	$17.5 \pm 0.7$	$0.68 \pm 0.027$	0.45	0.017	16.4	0.645	
	XGB..	1.25	4.46	0.24	0.86	19.2	0.75	$17.5 \pm 0.7$	$0.68 \pm 0.027$	0.2	0.007	16.4	0.645	
	XGC..	0.65	2.32	0.08	1.29	19.2	0.75	$17.5 \pm 0.7$	$0.68 \pm 0.027$	0.2	0.007	16.4	0.645	
	XGH..	1.37	4.85	0.04	0.14	19.2	0.75	$17.3 \pm 0.7$	$0.68 \pm 0.027$	0.45	0.017	16.9	0.665	
-L20 Lever (mm) 	XGG..	3.2	11.43	0.38	1.36	21.8	0.85	$20.5 \pm 0.6$	$0.81 \pm 0.023$	0.4	0.015	19.5	0.767	
	XGA..	3.2	11.43	0.85	3.04	21.8	0.85	$20.5 \pm 0.6$	$0.81 \pm 0.023$	0.2	0.007	19.5	0.767	
	XGM..	2	7.14	0.48	1.71	21.8	0.85	$20.3 \pm 0.6$	$0.8 \pm 0.023$	0.4	0.015	19.8	0.779	
	XGO..	1.2	4.29	0.09	0.32	21.8	0.85	$20.1 \pm 0.6$	$0.79 \pm 0.023$	0.4	0.015	19.8	0.779	
	XGK..	1.5	5.36	0.19	0.68	21.8	0.85	$20.5 \pm 0.6$	$0.81 \pm 0.023$	0.4	0.015	19.5	0.767	
	XGB..	1.5	5.36	0.29	1.04	21.8	0.85	$20.5 \pm 0.6$	$0.81 \pm 0.023$	0.2	0.007	19.5	0.767	
	XGC..	0.8	2.86	0.09	0.32	21.8	0.85	$20.5 \pm 0.6$	$0.81 \pm 0.023$	0.2	0.007	19.5	0.767	
	XGH..	0.45	1.61	0.04	0.14	21.8	0.85	$20.3 \pm 0.6$	$0.8 \pm 0.023$	0.4	0.015	19.8	0.779	
-S20 Lever (mm) 	XGG..	3.2	11.43	0.37	1.32	21.8	0.85	$20.2 \pm 0.7$	$0.79 \pm 0.027$	0.4	0.015	19.3	0.759	
	XGA..	3.2	11.43	0.56	2	21.8	0.85	$20.2 \pm 0.7$	$0.79 \pm 0.027$	0.2	0.007	19.3	0.759	
	XGM..	2	7.14	0.47	1.68	21.8	0.85	$20.1 \pm 0.7$	$0.79 \pm 0.027$	0.4	0.015	19.7	0.775	
	XGO..	1.2	4.29	0.09	0.32	21.8	0.85	$20.1 \pm 0.7$	$0.79 \pm 0.027$	0.4	0.015	19.7	0.775	
	XGK..	1.5	5.36	0.18	0.64	21.8	0.85	$20.2 \pm 0.7$	$0.79 \pm 0.027$	0.4	0.015	19.3	0.759	
	XGB..	1.5	5.36	0.28	1	21.8	0.85	$20.2 \pm 0.7$	$0.79 \pm 0.027$	0.2	0.007	19.3	0.759	
	XGC..	0.8	2.86	0.09	0.32	21.8	0.85	$20.2 \pm 0.7$	$0.79 \pm 0.027$	0.2	0.007	19.3	0.759	
	XGH..	0.45	1.61	0.04	0.14	21.8	0.85	$20.1 \pm 0.7$	$0.79 \pm 0.027$	0.4	0.015	19.7	0.775	
-T20 * Lever (mm) 	XGG..	3.2	11.43	0.37	1.32	21.8	0.85	$20.2 \pm 0.7$	$0.79 \pm 0.027$	0.4	0.015	19.3	0.759	
	XGA..	3.2	11.43	0.56	2	21.8	0.85	$20.2 \pm 0.7$	$0.79 \pm 0.027$	0.2	0.007	19.3	0.759	
	XGM..	2	7.14	0.05	1.68	21.8	0.85	$20.1 \pm 0.7$	$0.79 \pm 0.027$	0.4	0.015	19.7	0.775	
	XGO..	1.2	4.29	0.09	0.32	21.8	0.85	$20.1 \pm 0.7$	$0.79 \pm 0.027$	0.4	0.015	19.7	0.775	
	XGK..	1.5	5.36	0.18	0.64	21.8	0.85	$20.2 \pm 0.7$	$0.79 \pm 0.027$	0.4	0.015	19.3	0.759	
	XGB..	1.5	5.36	0.28	1	21.8	0.85	$20.2 \pm 0.7$	$0.79 \pm 0.027$	0.2	0.007	19.3	0.759	
	XGC..	0.8	2.86	0.09	0.32	21.8	0.85	$20.2 \pm 0.7$	$0.79 \pm 0.027$	0.2	0.007	19.3	0.759	
	XGH..	0.45	1.61	0.04	0.14	21.8	0.85	$20.1 \pm 0.7$	$0.79 \pm 0.027$	0.4	0.015	19.7	0.775	

1) Lever distance 8.2 (0.32) for lever position –20, lever position (–J20, L20, S20, M20)  
 Lever distance 14.0 (0.55) for lever position –40, lever position (–J40, L40, S40, M40)

\* For high temperature T125° C/T 150° C (ENEC, UL)

# Snap-action Microswitches – Miniature XG

## Ordering Reference – How to Build a Part Number

<None>Type	XGG..	3.2 N	11.43 oz
Actuating	XGA../XGT..	3.2 N	11.43 oz
Characteristic	XGM..	2.0 N	7.14 oz
	XGO..	1.2 N	4.29 oz
	XGK..	1.5 N	5.36 oz
	XGB..	1.5 N	5.36 oz
	XGC..	0.8 N	2.86 oz
	XGH..	0.45 N	1.61 oz
	XGD..	1.7 N	6.07 oz

Circuit	No digit	Change-over
	4	Normally closed
	5	Normally open

Terminals	02	Faston	6.3 x 0.8
	03	Solder	1.7 x 3.2
	06	Faston	4.8 x 0.5
	10	Faston	4.8 x 0.8
	12	Short solder	Ø 2.3
	15	RAST 5	6.3 x 0.8

Other types of terminals are available on request

Version	No digit	ENEC	UL	Number of operations at rated load	
				Europe	UL
	A	T85	T90	50.000	6.000
	W	T85	T90	50.000	100.000
	AW	T150	T150	50.000	6.000
	B	T150	T150	50.000	100.000
	V	T85	T90	10.000	6.000
	AV	T125	T130	50.000	6.000
	C	T125	T130	50.000	100.000
		T85	T90	25.000	6.000

Contacts	-88	Ag / AgNi10
	-81	Gold-plated 4 µm (Au) on Ag
	-86	Ag / Ag CdO

Actuators	No digit	Plunger	
	J20/J40	Plain lever	13.5 mm
	J22/J42	Plain lever	24.0 mm
	J23/J43	Plain lever	27.8 mm
	J27/J47	Plain lever	60.0 mm
	M20/M40	Plain lever formed	14.7 mm
	L20/L40	Cam follower	12.5 mm
	L21/L41	Cam follower	25.9 mm
	S20/S40	Roller lever	12.8 mm
	T20/T40	Roller lever. 150° C version	12.8 mm

Other actuators available on request