

Screw Connectors for Printed Circuit Boards

TYPE 930-T (-DS)

3.5 mm spacing - 2 and 3 poles



Series	Download PDF	3D Model	Can plug with	How to order	Color specifications	Print
------------------------	------------------------------	--------------------------	-------------------------------	------------------------------	--------------------------------------	-----------------------

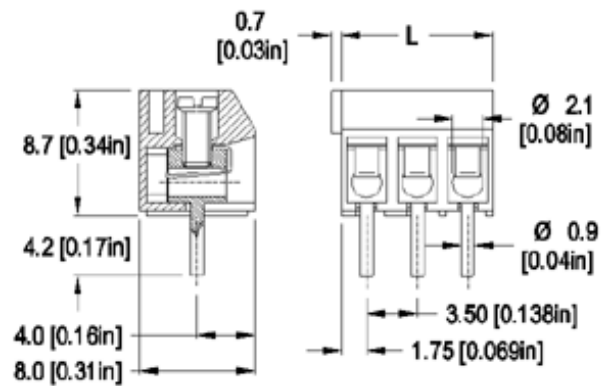
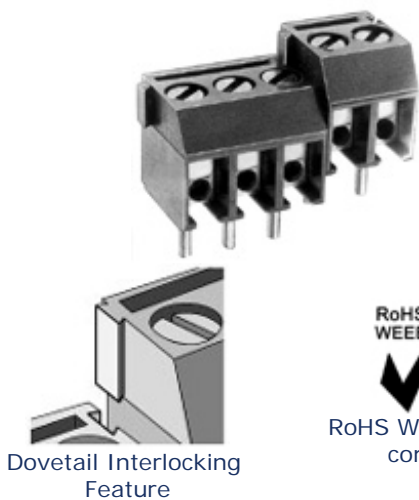

Dimensions: mm (in.)

Length of Connector (L)

L = No. of Poles x Center to Center Spacing

When locating connector, allow 0.5 mm clearance around it for process-induced variations.

Description

- Dovetail version
- low profile
- Wire entrance parallel to PC Board
- Can be factory, field or distributor assembled to almost any length

Technical Data

Center to Center Spacing: 3.5 mm (0.138 in.)

Nominal Cross Section:

1 mm² (1550 mils²)

Wire Stripping Length: 6 mm (0.25 in.)

Recommended Hole Diameter in PC Board:

1.2 mm (0.047 in.)

Approval Information

UL File No.E69841

CSA File No.LR24322

Rating	Current(A)	Voltage(V)	Application group	AWG
UL	10	300	B	26-16
CSA	7	300	B,E	26-16

* DS version is CSA certified for 26-18 AWG.

Screw Tightening Torque:

UL: 2.0 lbf·in

CSA: 0.2 Nm

Rated Impulse Withstand Voltage: 2500 V

Material

Molding: Polyamide, self extinguishing UL 94, V-0, color grey

Temperature limits:

Short Time: 140°C (284°F)

Continuous: RTI 105°C (221°F)

Low Limit: -40°C (-40°F)

Comparative Tracking Index: CTI > 600

Oxygen Index Rating: 33%

 [Top of page](#)

Terminal Body: Tin plated copper alloy

Wire Protector: Nickel silver

Screw: M2, Slotted head, zinc plated blue passivated, steel substrate

Solder Pin: Ø 0.9 mm (0.035 in.), Tin plated copper alloy

How to order

Item 930-T (-DS)

Options

CN: Consecutive Numbering (hot stamped numbers)

SM: Special Marking (please provide sketch)

G05: Gold Plating (5 micro inches)

G30: Gold Plating (30 micro inches)

S30: Silver Plating (30 micro inches)

Note: Plated component: terminal body

WIRE PROTECTOR:
with: - DS

POLES:
02 and 03

930-T

/

[Request sample](#)

[Request quote](#)

Quantity

Accessories

[BST Self Adhesive Marking Strips.](#)

[Consecutively numbered.](#)

[Add to shopping cart](#)