

# Level Sensors

## Optical

### Type VP, Unmodulated

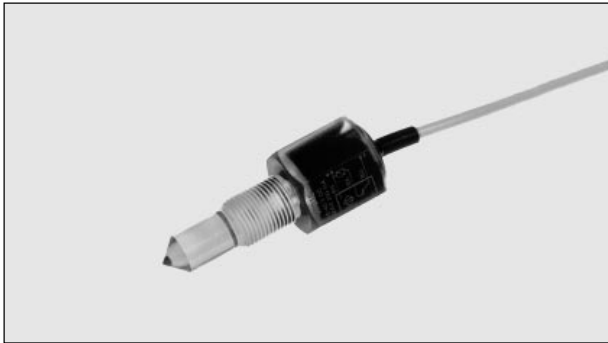

- Unmodulated infrared sensor for liquid level detection
- Approved for Ex-applications (DC-types)
- Built-in amplifier, Ga-As diode
- Output: Transistor NPN/PNP or SCR, make or break switching
- High chemical resistance to most acids and bases
- VP01/03: Output OFF when sensor in liquid
- VP02/04: Output ON when sensor in liquid
- No electrical or thermal connection between liquid and electrical circuit
- LED-indication for output ON
- Power supply: DC types: 10 to 40 VDC  
AC types: 110 or 230 VAC

### Product Description

Optical level sensor with unmodulated, infrared light for the detection of liquids. Fitted with built-in amplifier. Transmitter and receiver are completely self-contained in solid plastic housing designed for mounting into container

wall. VP01/02 are available in a Polysulphone housing resistant to most acids and bases. VP03/04 are available in a Polyamide 12 housing resistant to various solvents.

### Ordering Key

**VP 0 3 E P**

Type \_\_\_\_\_  
Housing \_\_\_\_\_  
Output status \_\_\_\_\_  
Output type \_\_\_\_\_  
PNP output \_\_\_\_\_

### Type Selection - DC Types (Ex-approved)

Housing material	Ordering no. Transistor NPN Make switching	Ordering no. Transistor NPN Break switching	Ordering no. Transistor PNP Make switching	Ordering no. Transistor PNP Break switching
Polysulphone	VP 02 E	VP 01 E	VP 02 EP	VP 01 EP
Polyamide 12	VP 04 E	VP 03 E	VP 04 EP	VP 03 EP

### Type Selection - AC Types

Housing material	Ordering no. Make switching 110 VAC	Ordering no. Break switching 110 VAC	Ordering no. Make switching 230 VAC	Ordering no. Break switching 230 VAC
Polysulphone	VP 02-110TB	VP 01-110TB	VP 02-230TB	VP 01-230TB

### Specifications

	Transistor NPN/PNP	SCR output AC types
Rated operational voltage	10 - 40 VDC	110 VAC: 100 - 121 VAC, 45 - 60 Hz 230 VAC: 195 - 265 VAC, 45 - 60 Hz
Rated operational current Continuous	200 mA	10 - 100 mA
Voltage drop	≤ 1.0 VDC	≤ 9.0 VAC
No-load supply current	≤ 12 mA	≤ 7 mA
Sensing accuracy Liquid level difference	Horizontal mounting: ± 5 mm Vertical mounting: ± 2.5 mm	Horizontal mounting: ± 5 mm Vertical mounting: ± 2.5 mm
Ambient light	0 - 100 lux	0 - 100 lux
Frequency of operating cycles (f)	30 Hz	5 Hz

## Specifications (cont.)

	Transistor NPN/PNP	SCR output AC types
<b>Environment</b>		
Degree of protection	IP 67	IP 67
Operating temperature	-20 to +80°C (-4 to +176°F)	-20 to +80°C (-4 to +176°F)
Storage temperature	-40 to +100°C (-40 to + 100°F)	-40 to +100°C (-40 to + 100°F)
<b>Indication for output status</b>	LED, yellow	LED, yellow
<b>Housing and tip material</b>		
VP01/02	Polysulphone	Polysulphone
VP03/04	Polyamide 12	
<b>Weight</b>	90 g	90 g
<b>Connection</b>	Cable (PVC), 2 m	Cable (PVC), 2 m
<b>Pressure</b>	10 bar at + 60°C	10 bar at + 60°C
<b>Pipe thread</b>	3/8" PT	3/8" PT
<b>Ex-approval</b>	DEMKO certificate of conformity no. 92C.103973X	

## Mode of Operation

The sensor contains IR transmitter, receiver and amplifier with transistor or SCR output. The light source is a Ga-As diode emitting infrared light.

The conical tip of the sensor forms an angle of 90°C. This angle acts as a prism, i.e. the beam, emitted from the Ga-As diode placed in one side of the sensor head, is reflected internally to the phototransistor placed in the other side of the sensor head, provided

that the tip of the sensor is situated in free air. If the sensor tip is immersed in a liquid, always having a refractive index different from air, the beam will not be refracted by the prism and the photo transistor will not receive any signal.

The sensor types can operate in oil, waste water, aqueous solutions such as beer, wine, alcohol etc. without any kind of accessory.

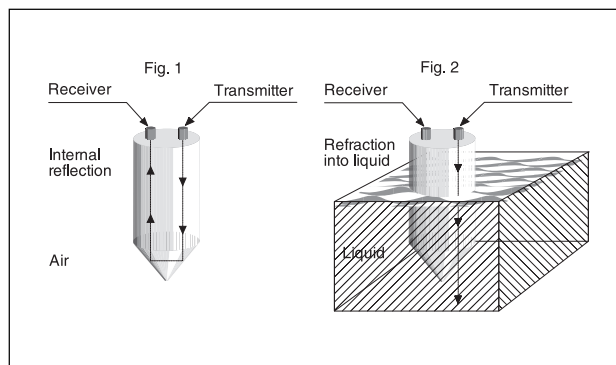

## Dimensions

