

Dimensions: mm (In.)

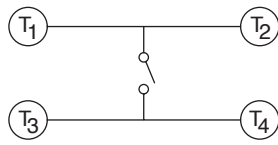

CIRCUIT DIAGRAM

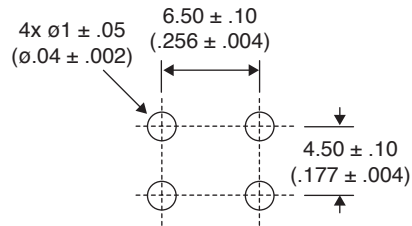
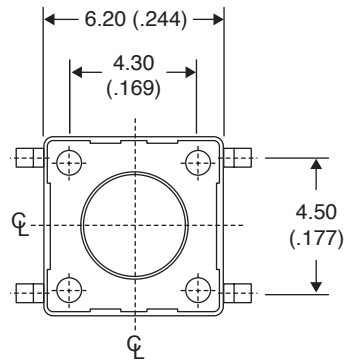
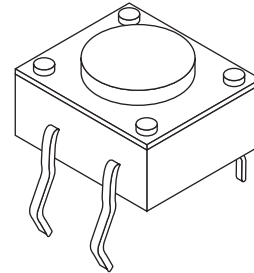

P.C.B. LAYOUT

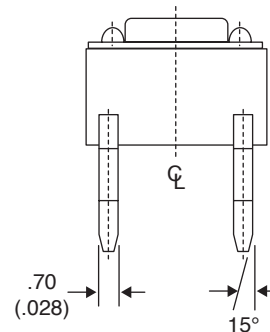
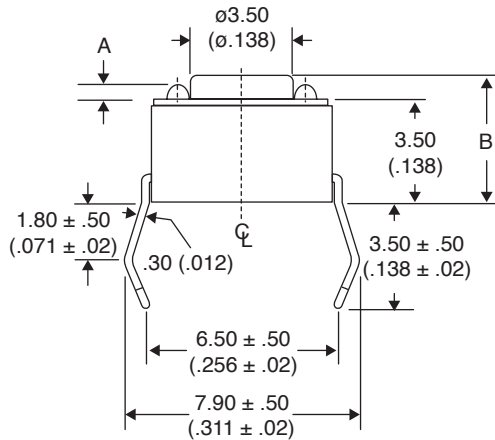

Mechanical Specifications:

- Operating Life: 300,000 cycles min.
- Operating Temperature: -25°C to +70°C

Electrical Specifications:

- Rating: 50mA / 12VDC
- Contact Resistance: 100mΩ max.
- Insulation Resistance: 100MΩ min.
- Dielectric Strength: 250VAC for 1 minute

Soldering Process:

- Temperature: 260 ± 5°C 5 ± 1 sec.

Part No.	Dimensions: mm (In)	
	A Max.	B
TS6111T1601	0.5 (.02)	4.3 (.169)
TS6111T1602	0.6 (.024)	5.0 (.197)
TS6111T1603	0.6 (.024)	7.0 (.275)
TS6111T1606	0.6 (.024)	9.5 (.374)
TS6111T1607	0.6 (.024)	13.0 (.512)

Tactile Switches
 TS6111T1601, TS6111T1602,
 TS6111T1603, TS6111T1606, TS6111T1607

