

**FEATURES/BENEFITS**

- Latest generation MOSFET technology
- Ultra low on-state resistance
- Innovative isolated driver ensures fast power transistor turn on and off and thus low power transient
- Ultra low output leakage current
- Low control current consumption
- Triggered control input to avoid linear control risks
- Low conducted and radiated disturbances



Part Number	Description
S60DC40	40A, 600 Vdc Solid-State Relay

**Part Number Explanation**

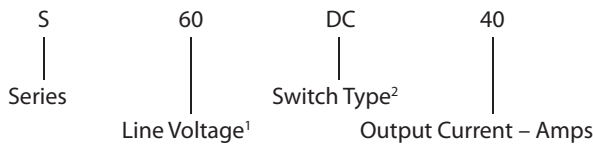

**NOTES**

- 1) Line Voltage (peak): 60 = 600 Vdc
- 2) Switch Type: DC = DC

**ELECTRICAL SPECIFICATIONS**

(+25°C ambient temperature unless otherwise specified)

**INPUT (CONTROL) SPECIFICATIONS**

	Min	Max	Units
Control Range	4.5	32	Vdc
Input Current Range	25	42	mAdc
Typical Turn-On Voltage	4.3		Vdc
Must Turn-Off Voltage	1		Vdc
Reverse Voltage		32	Vdc
Reverse Leakage Current		100	µA

**CONTROL CHARACTERISTIC**

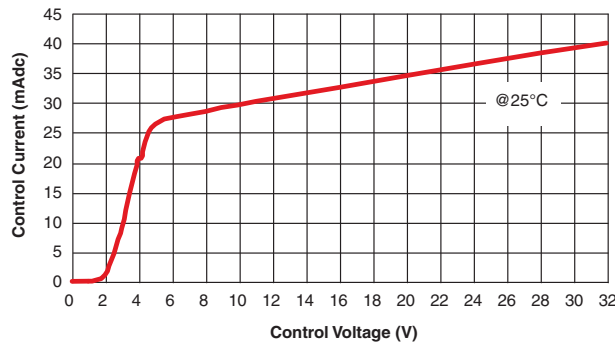
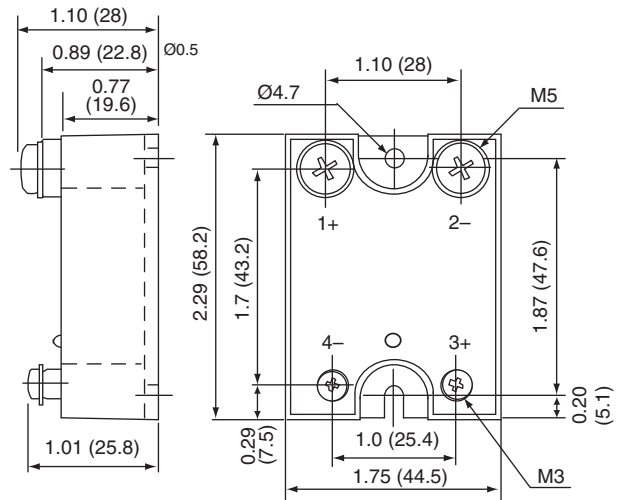

Figure 2

**MECHANICAL SPECIFICATION**



Tolerances: Ø0.3  
Dimensions in inches (mm)  
Weight: 3.52 oz. (100g)

Figure 1

**BLOCK DIAGRAM**

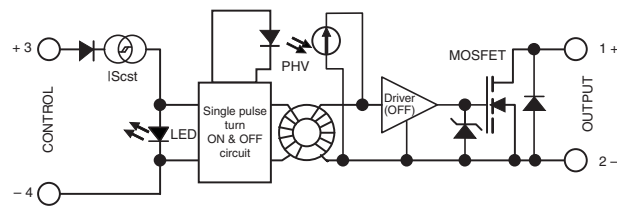

Figure 3

**ELECTRICAL SPECIFICATIONS**  
(+25°C ambient temperature unless otherwise specified)

**OUTPUT (LOAD) SPECIFICATIONS**

	Min	Max	Units
Operating Range	0	350*	Vdc
Peak Voltage		600	Vpeak
Reverse Voltage (Internal Diode)	1.2		V
Maximum Repetitive Avalanche Current		20	A
Maximum Single Pulse Avalanche Energy		1800	mJ
Maximum Repetitive Pulse Avalanche Energy		1	mJ
Maximum Nominal Currents (Resistive)		40	A
Non-Repetitive Peak Overload Current		140	A
Leakage Current		250	μAdc
On-State Resistance		70	mΩ
Output Capacitance (Typical)	2.2		nF
Junction-Case Thermal Resistance		0.4	°C/W
Built-In Heat Sink Thermal Resistance (Vertically Mounted)		8	°C/W
Heat Sink Thermal Time Constant		10	min
Control Inputs/Power Outputs Insulation Voltage		4	kV
Turn-On Time		10	μs
Turn-On Delay		600	μs
Turn-Off Time		10	μs
Turn-Off Delay		100	μs
On-Off Frequency		700	Hz

\*Recommend 275 Vrms size 20 varistor as protection across the output.

**HIGH SIDE WIRING DIAGRAM**  
(Load Connected to "—")

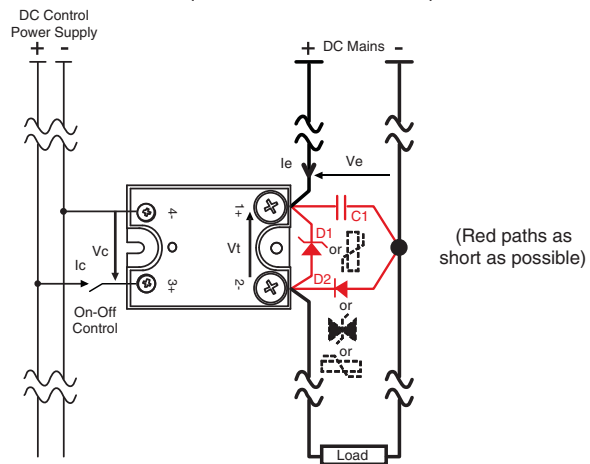

Figure 4

**LOW SIDE WIRING DIAGRAM**  
(Load Connected to "+")

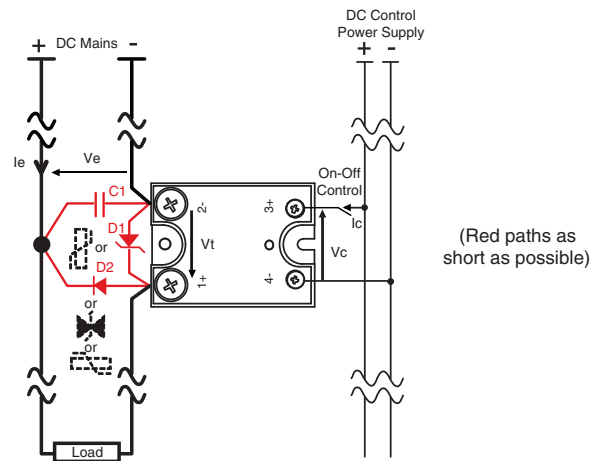

Figure 5

**TIME DIAGRAMS**

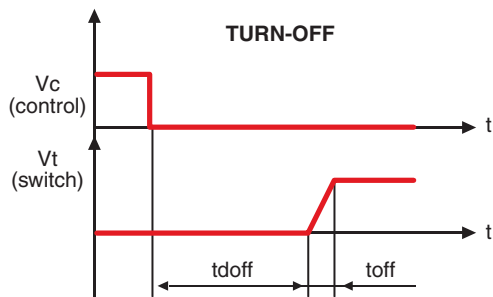
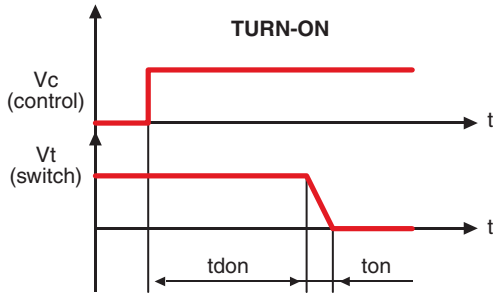

Figure 6

**ON RESISTANCE VS. TEMPERATURE**

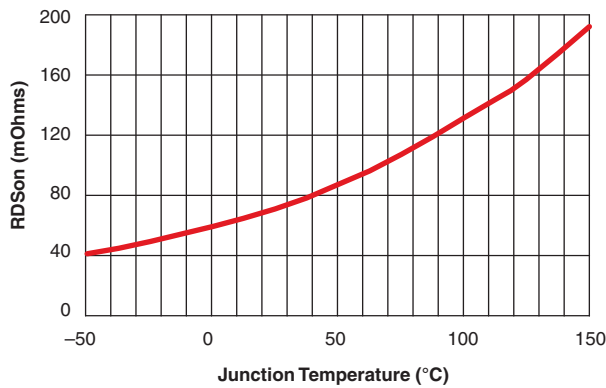

Figure 7

**GENERAL SPECIFICATIONS**

(+25°C ambient temperature unless otherwise specified)

**ENVIRONMENTAL SPECIFICATIONS**

	Min	Max	Units
Operating Temperature	-40	+90	°C
Storage Temperature	-55	+100	°C
Input-Output Isolation	4000		Vrms
Insulation Resistance	1		GΩ
Insulation Capacitance	8		pF
Junction Temperature		150	°C

**CONNECTIONS**

	Power	Control
Screwdriver	Phillips NR2	Phillips NR1
Tightening Torque	1.8 N.m	0.8 N.m
Insulated crimp terminals (Round Tabs, Eyelet Type)	M5	M3

**MISCELLANEOUS**

Display	Green LED (ON)
Housing	UL94V0
Mounting	2 screws (M4x12mm)
Noise Level	No audible noise

**GENERAL**

Standards	IEC60947-1
Protection Level	IP00
Protection Against Direct Touch	None
CE Marking	Yes
UL, cULUS & VDE Approvals	Pending

**E.M.C. EMISSION**

Radiated & Conducted Disturbances	NFEN55011
-----------------------------------	-----------

**POWER DISSIPATION AND LOAD CURRENT LIMIT VS. TEMPERATURE**

Please refer to the installation notice for precautions about mounting the device on a heat sink.

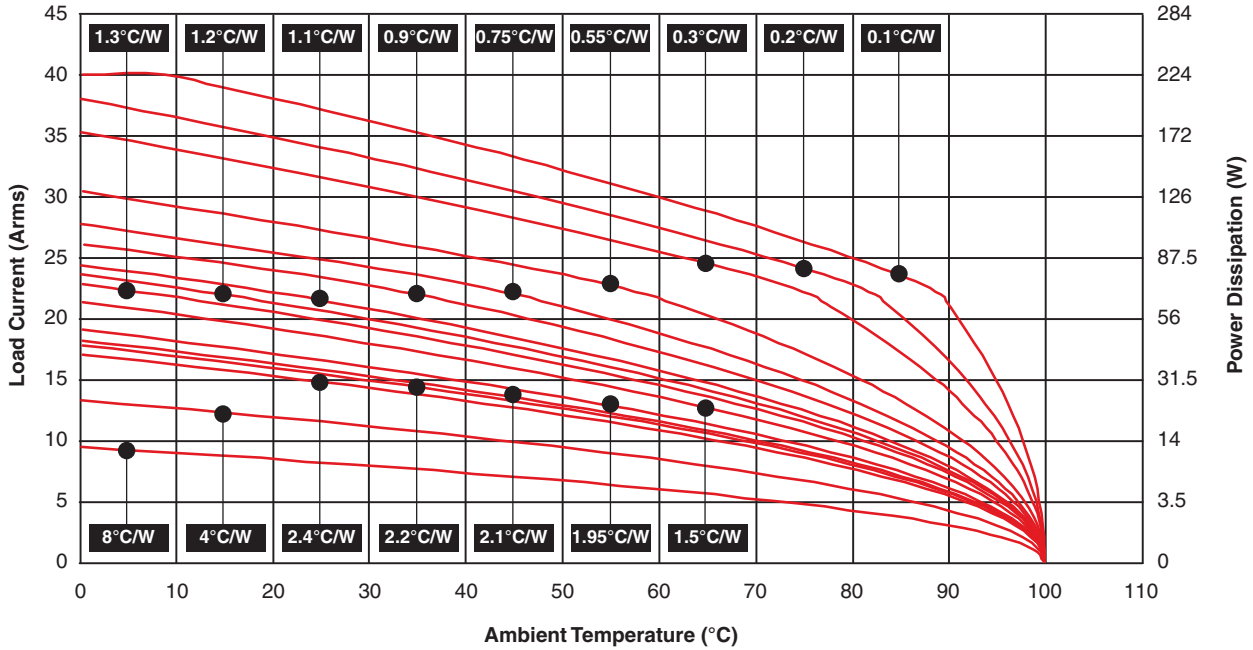

Figure 8

PROTECTIVE COVER AVAILABLE  
Add -14 to part number

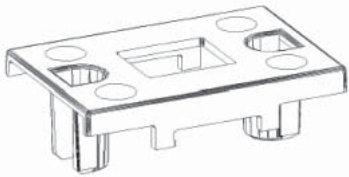

Figure 9

NOTES

- For additional/custom options, contact factory.

**CURRENT OVERLOAD CHARACTERISTICS**

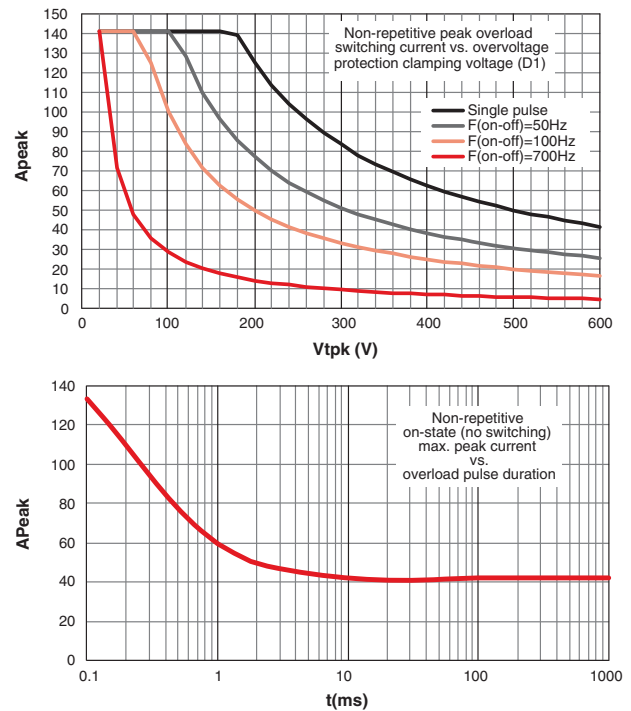

Figure 10