

## SNA\_6A



### Features

- DIN rail installation (option)
- Best filter for switch mode power supplies of analog circuits (ex. power supply filter for an operational amplifier)
- Terminal block type (SNA-6A Option)
- $\pm 50$  VDC
- RoHS Compliant

### Safety Agency Approvals

- UL60950-1
- EN60950-1
- C-UL (CSA60950-1)

Model	Rated Voltage [V]	Rated Current [A]
SNA-06-223	$\pm 50$ (+Vin - COM-in, -Vin - COM-in)	6

# SNA series (6A)

SNA -06 -223 -□

① ② ③ ④

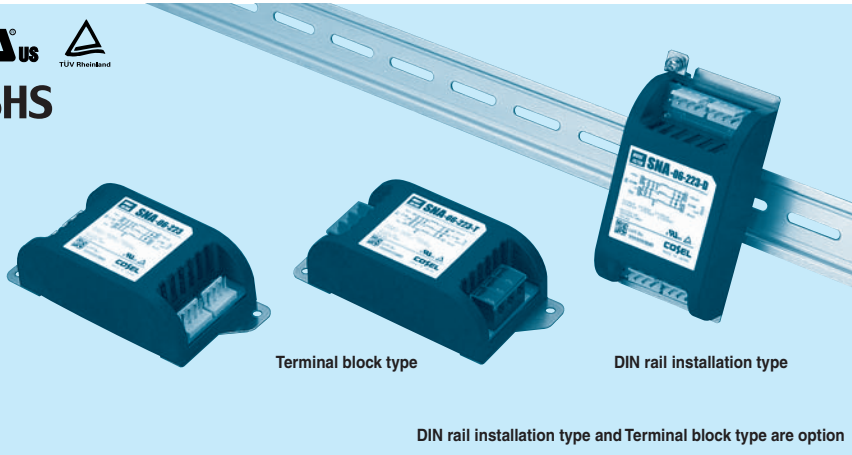

- ① Model Name
- ② Rated Current
- ③ Line to ground capacitor code: See table 1.1.

table1.1 Line to ground capacitor code

Code	Line to ground capacitor (nominal value)
000	Not Provided
223	22000pF

- ④ Options
- D :DIN rail installation type
- T :Terminal block type
- DT:Terminal block and DIN rail type

\* The dimensions change when the option is set. Refer to External view.

## Features of SNA series (6A)

### Ripple noise attenuation type for switch mode power supplies(DC)

· ±50 VDC

- Best filter for switch mode power supplies of analog circuits  
(ex. power supply filter for an operational amplifier)

### Specifications

No.	Items	SNA-06-223
		Interfare:Connector
1	Rated Voltage DC[V]	±50 (+Vin - COM-in, -Vin - COM-in)
2	Rated Current DC[A]	6
3	Test Voltage (Terminal-Mounting Plate)	500 VAC (Cutoff Current = 100mA), 1minute at room temperature and humidity
4	Isolation Resistance (Terminal-Mounting Plate)	500 VDC 50MΩ minute at room temperature and humidity
5	D.C Resistance[mΩ]	50 max
6	Operating temperature	-40 to +71°C (Refer to Derating Curve)
7	Operating humidity	20 to 95%RH (Non condensing)
8	Storage temperature/humidity	-40 to +75°C/20 to 95%RH (Non condensing)
9	Vibration	10 to 55Hz, 19.6m/s <sup>2</sup> (2G), 3min. Period, 1hour each X, Y and Z axis
10	Impact	196.1m/s <sup>2</sup> (20G), 11ms Once each X, Y and Z axis
11	Safety agency approvals	UL60950-1, C-UL (CSA60950-1), EN60950-1
12	Case size (without projection) /Mass	52 X 35 X 117 mm (W X H X D) /150g max (Option : -D, -T, -DT refer to external view)

### Circuit Diagram

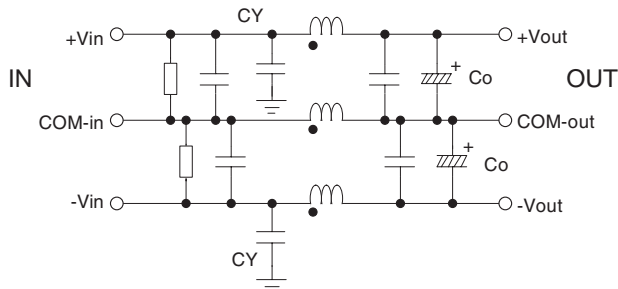

CY : Line to ground capacitor Co : Electrolytic capacitor : Mounting Plate

■Expected life : 10 years

### Derating Curve

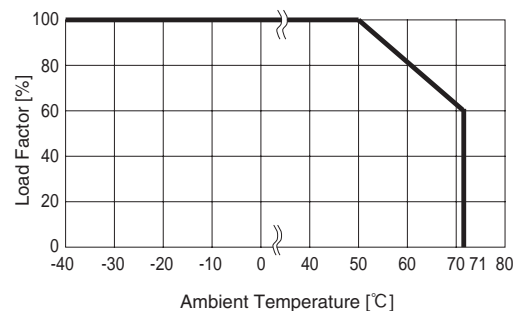

## External view

### Standard Type

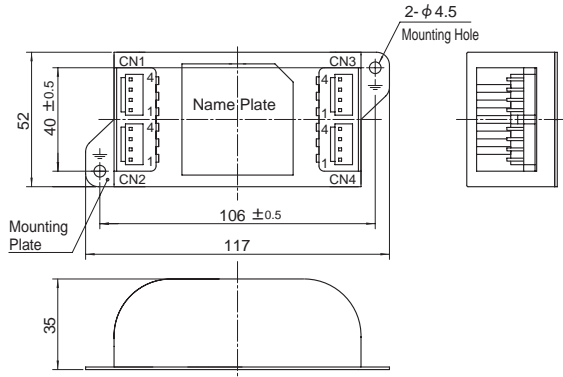

CN1		CN3	
Pin No.	Function	Pin No.	Function
1,2	COM-in	1,2	COM-out
3,4	+Vin	3,4	+Vout

CN2		CN4	
Pin No.	Function	Pin No.	Function
1,2	-Vin	1,2	-Vout
3,4	COM-in	3,4	COM-out

- ※ Tolerance : ±1
- ※ Mass : 150g or less
- ※ PCB Material /thickness : CEM3 /1.6mm
- ※ Mounting plate : Iron (surface finishing : nickel plating) t=1.0
- ※ Case : PBT
- ※ Dimensions in mm
- ※ Keeping drawing current per pin below 5A for CN1 to CN4

I/O Connector	Mating connector	Terminal
CN1-CN4	B4P-VH	VHR-4N
		Reel:SVH-21T-P1.1
		Bulk:BVH-21T-P1.1

(Mfr.:J.S.T)

Option harness : Refer to Instruction Manual 4

### Terminal block Type

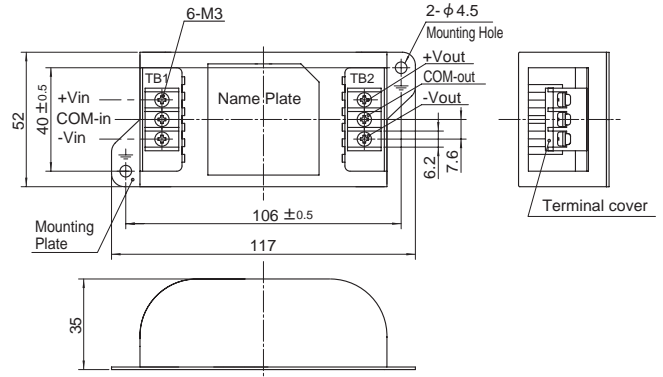

- ※ Tolerance : ±1
- ※ Mass : 160g or less
- ※ PCB Material /thickness : CEM3 /1.6mm
- ※ Mounting plate : Iron (surface finishing : nickel plating) t=1.0
- ※ Case : PBT
- ※ Dimensions in mm
- ※ Terminal block screw tightening torque M3:0.8N · m (8.5kgf · cm) max

### DIN rail installation Type

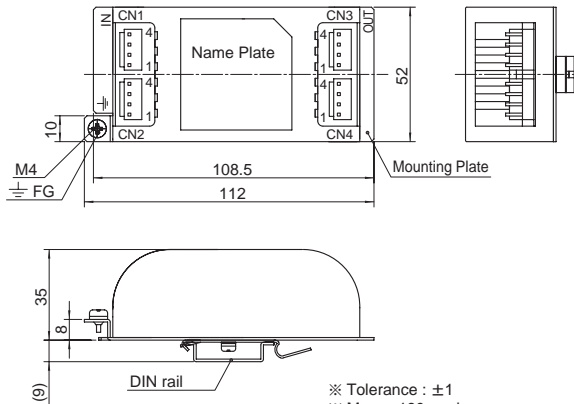

CN1		CN3	
Pin No.	Function	Pin No.	Function
1,2	COM-in	1,2	COM-out
3,4	+Vin	3,4	+Vout

CN2		CN4	
Pin No.	Function	Pin No.	Function
1,2	-Vin	1,2	-Vout
3,4	COM-in	3,4	COM-out

- ※ Tolerance : ±1
- ※ Mass : 160g or less
- ※ PCB Material /thickness : CEM3 / 1.6mm
- ※ Mounting plate : Iron (surface finishing : nickel plating) t=1.0
- ※ Case : PBT
- ※ Dimensions in mm
- ※ Keeping drawing current per pin below 5A for CN1 to CN4

I/O Connector	Mating connector	Terminal
CN1-CN4	B4P-VH	VHR-4N
		Reel:SVH-21T-P1.1
		Bulk:BVH-21T-P1.1

(Mfr.:J.S.T)

Option harness : Refer to Instruction Manual 4

### Terminal block type+DIN rail installation Type

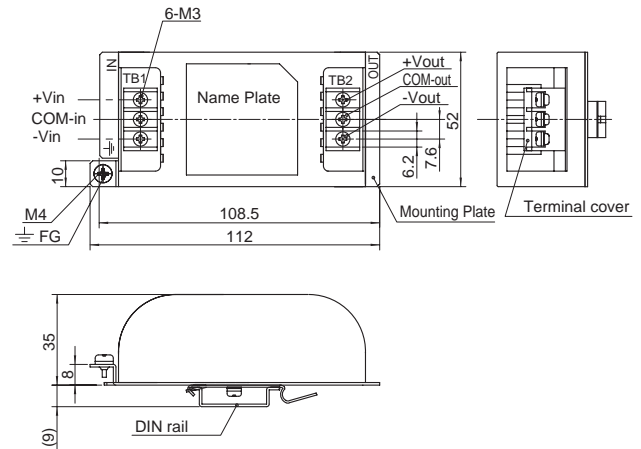

- ※ Tolerance : ±1
- ※ Mass : 170g or less
- ※ PCB Material /thickness : CEM3 /1.6mm
- ※ Mounting plate : Iron (surface finishing : nickel plating) t=1.0
- ※ Case : PBT
- ※ Dimensions in mm
- ※ Terminal block screw tightening torque M3:0.8N · m (8.5kgf · cm) max

## ■Note when installing the noise filter on a DIN rail.

When the noise filter is grounded through the DIN rail, the proper noise attenuation may not be achieved.

Be sure to connect the FG terminal of the noise filter body to the earth.

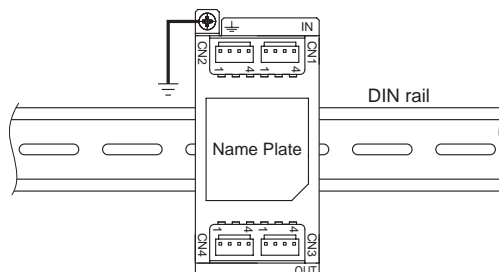

Noise Filter