

AC Series Tubeaxial Cooling Fans Model No. A36T10

3.62" Sq. x 1.00"
(92 mm Sq. x 25 mm)
16-35 CFM
(7.6-16.5 L/Sec.)



Features

- Reliable shaded-pole motor construction
- Precision ball bearing system provides:
 - Longer life
 - Higher temperature extremes
 - Lower noise over time
 - Maximum shock and vibration resistance
- Rugged die-cast aluminum housing for maximum heat dissipation

Accessories:
Finger guards
Power cords

General Specifications

- Frame:** Die-cast aluminum painted black for moisture and corrosion resistance
- Impeller:** Reinforced polybutylene plastic (UL94V-0 rating)
- Bearings:** Precision, life-lubricated ball bearings
- Insulation:** Class A integral ground system rated @ 248°F (120°C)
- Weight:** 10.5 ozs. (300 grams)
- Operating Temperature Range:** 14° to 158°F (-10° to 70°C)
- Insulation Resistance:** 100 megohms minimum @ 500 VDC
- Dielectric Strength:** 1500 VAC for 3 seconds
- Safety Protection:** Impedance protected
- Life Expectancy:** 50,000 hours minimum @ 77°F (25°C)

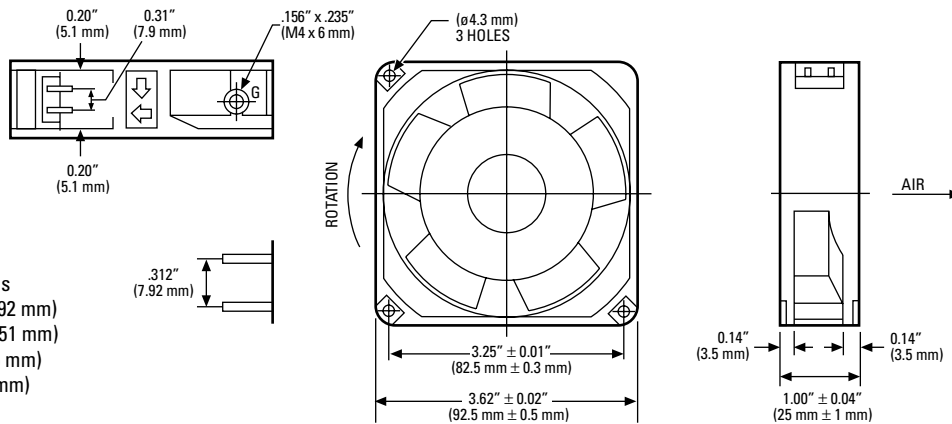

Terminals
2 Solder Terminals
Centers: .312" (7.92 mm)
Thickness: .02" (.51 mm)
Width: .120" (3.05 mm)
Length: .31" (7.8 mm)

Globe Motors Part Number	Nominal Voltage VAC	Frequency Hz	Watts	Line Amps	RPM	Acoustic Noise dBA	Airflow (Min.)	
							CFM	Liters per Second
A36-B10A-15T1-000	115	50 / 60	7.0 / 6.0	0.090 / 0.080	1450 / 1800	22 / 25	16 / 20	7.6 / 9.4
A36-B10A-15T2-000	115	50 / 60	7.0 / 6.0	0.095 / 0.090	2100 / 2500	30 / 35	21 / 28	9.9 / 13.2
A36-B10A-15T3-000	115	50 / 60	12.0 / 9.0	0.170 / 0.130	2600 / 3100	34 / 38	28 / 35	13.2 / 16.5
A36-B10A-23T1-000	230	50 / 60	7.0 / 6.0	0.050 / 0.040	1450 / 1800	22 / 26	16 / 20	7.6 / 9.4
A36-B10A-23T2-000	230	50 / 60	7.0 / 6.0	0.050 / 0.050	2100 / 2500	30 / 35	21 / 28	9.9 / 13.2
A36-B10A-23T3-000	230	50 / 60	13.0 / 10.0	0.090 / 0.070	2600 / 3100	34 / 39	28 / 35	13.2 / 16.5

Installation Guide

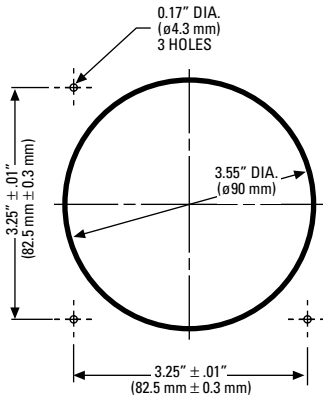

Performance at Sea Level

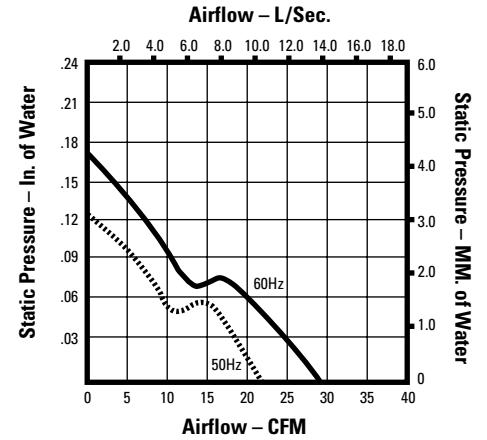
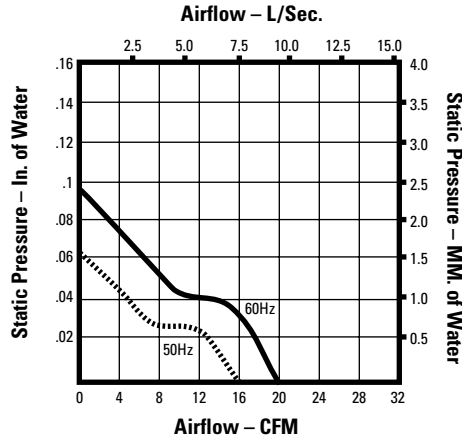

Approvals



UL File No.
E105397



CSA File No.
72877



VDE File No.
17074-2611-0705



NOTES:

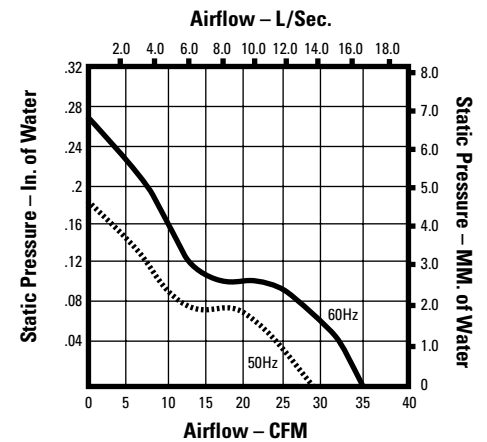
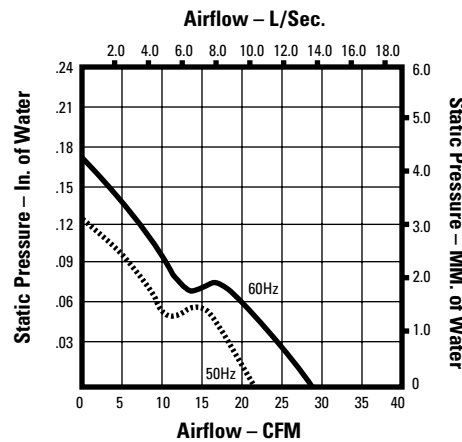
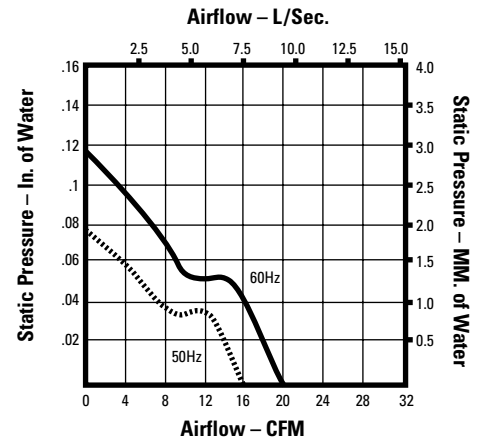
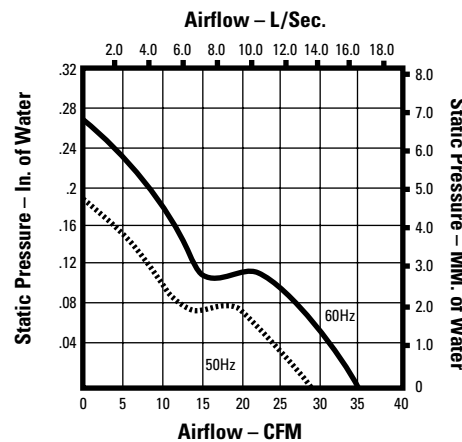

All operating specifications measured at nominal operating voltage, free air at sea level