



# **PIC16F631/677/685/687/689/690**

## **Data Sheet**

20-Pin Flash-Based, 8-Bit  
CMOS Microcontrollers with  
nanoWatt Technology

---

**Note the following details of the code protection feature on Microchip devices:**

- Microchip products meet the specification contained in their particular Microchip Data Sheet.
- Microchip believes that its family of products is one of the most secure families of its kind on the market today, when used in the intended manner and under normal conditions.
- There are dishonest and possibly illegal methods used to breach the code protection feature. All of these methods, to our knowledge, require using the Microchip products in a manner outside the operating specifications contained in Microchip's Data Sheets. Most likely, the person doing so is engaged in theft of intellectual property.
- Microchip is willing to work with the customer who is concerned about the integrity of their code.
- Neither Microchip nor any other semiconductor manufacturer can guarantee the security of their code. Code protection does not mean that we are guaranteeing the product as "unbreakable."

Code protection is constantly evolving. We at Microchip are committed to continuously improving the code protection features of our products. Attempts to break Microchip's code protection feature may be a violation of the Digital Millennium Copyright Act. If such acts allow unauthorized access to your software or other copyrighted work, you may have a right to sue for relief under that Act.

---

Information contained in this publication regarding device applications and the like is provided only for your convenience and may be superseded by updates. It is your responsibility to ensure that your application meets with your specifications. MICROCHIP MAKES NO REPRESENTATIONS OR WARRANTIES OF ANY KIND WHETHER EXPRESS OR IMPLIED, WRITTEN OR ORAL, STATUTORY OR OTHERWISE, RELATED TO THE INFORMATION, INCLUDING BUT NOT LIMITED TO ITS CONDITION, QUALITY, PERFORMANCE, MERCHANTABILITY OR FITNESS FOR PURPOSE. Microchip disclaims all liability arising from this information and its use. Use of Microchip devices in life support and/or safety applications is entirely at the buyer's risk, and the buyer agrees to defend, indemnify and hold harmless Microchip from any and all damages, claims, suits, or expenses resulting from such use. No licenses are conveyed, implicitly or otherwise, under any Microchip intellectual property rights.

**Trademarks**

The Microchip name and logo, the Microchip logo, Accuron, dsPIC, KEELOQ, microID, MPLAB, PIC, PICmicro, PICSTART, PRO MATE, PowerSmart, rPIC and SmartShunt are registered trademarks of Microchip Technology Incorporated in the U.S.A. and other countries.

AmpLab, FilterLab, Migratable Memory, MXDEV, MXLAB, SEEVAL, SmartSensor and The Embedded Control Solutions Company are registered trademarks of Microchip Technology Incorporated in the U.S.A.

Analog-for-the-Digital Age, Application Maestro, CodeGuard, dsPICDEM, dsPICDEM.net, dsPICworks, ECAN, ECONOMONITOR, FanSense, FlexROM, fuzzyLAB, In-Circuit Serial Programming, ICSP, ICEPIC, Linear Active Thermistor, Mindi, MiWi, MPASM, MPLIB, MPLINK, PICkit, PICDEM, PICDEM.net, PICLAB, PICtail, PowerCal, PowerInfo, PowerMate, PowerTool, REAL ICE, rLAB, rPICDEM, Select Mode, Smart Serial, SmartTel, Total Endurance, UNI/O, WiperLock and ZENA are trademarks of Microchip Technology Incorporated in the U.S.A. and other countries.

SQTP is a service mark of Microchip Technology Incorporated in the U.S.A.

All other trademarks mentioned herein are property of their respective companies.

© 2006, Microchip Technology Incorporated, Printed in the U.S.A., All Rights Reserved.

 Printed on recycled paper.

**QUALITY MANAGEMENT SYSTEM**  
**CERTIFIED BY DNV**  
**== ISO/TS 16949:2002 ==**

*Microchip received ISO/TS-16949:2002 certification for its worldwide headquarters, design and wafer fabrication facilities in Chandler and Tempe, Arizona, Gresham, Oregon and Mountain View, California. The Company's quality system processes and procedures are for its PICmicro® 8-bit MCUs, KEELOQ® code hopping devices, Serial EEPROMs, microperipherals, nonvolatile memory and analog products. In addition, Microchip's quality system for the design and manufacture of development systems is ISO 9001:2000 certified.*



# MICROCHIP PIC16F631/677/685/687/689/690

## 20-Pin Flash-Based, 8-Bit CMOS Microcontrollers with nanoWatt Technology

### High-Performance RISC CPU:

- Only 35 instructions to learn:
  - All single-cycle instructions except branches
- Operating speed:
  - DC – 20 MHz oscillator/clock input
  - DC – 200 ns instruction cycle
- Interrupt capability
- 8-level deep hardware stack
- Direct, Indirect and Relative Addressing modes

### Special Microcontroller Features:

- Precision Internal Oscillator:
  - Factory calibrated to  $\pm 1\%$
  - Software selectable frequency range of 8 MHz to 32 kHz
  - Software tunable
  - Two-Speed Start-up mode
  - Crystal fail detect for critical applications
  - Clock mode switching during operation for power savings
- Power-Saving Sleep mode
- Wide operating voltage range (2.0V-5.5V)
- Industrial and Extended Temperature range
- Power-on Reset (POR)
- Power-up Timer (PWRT) and Oscillator Start-up Timer (OST)
- Brown-out Reset (BOR) with software control option
- Enhanced low-current Watchdog Timer (WDT) with on-chip oscillator (software selectable nominal 268 seconds with full prescaler) with software enable
- Multiplexed Master Clear/Input pin
- Programmable code protection
- High Endurance Flash/EEPROM cell:
  - 100,000 write Flash endurance
  - 1,000,000 write EEPROM endurance
  - Flash/Data EEPROM retention: > 40 years
- Enhanced USART module:
  - Supports RS-485, RS-232 and LIN 2.0
  - Auto-Baud Detect
  - Auto-wake-up on Start bit

### Low-Power Features:

- **Standby Current:**
  - 50 nA @ 2.0V, typical
- Operating Current:
  - 11  $\mu$ A @ 32 kHz, 2.0V, typical
  - 220  $\mu$ A @ 4 MHz, 2.0V, typical
- Watchdog Timer Current:
  - <1  $\mu$ A @ 2.0V, typical

### Peripheral Features:

- 17 I/O pins and 1 input only pin:
  - High current source/sink for direct LED drive
  - Interrupt-on-Change pin
  - Individually programmable weak pull-ups
  - Ultra Low-Power Wake-up (ULPWU)
- Analog Comparator module with:
  - Two analog comparators
  - Programmable on-chip voltage reference (CVREF) module (% of VDD)
  - Comparator inputs and outputs externally accessible
  - SR Latch mode
  - Timer 1 Gate Sync Latch
  - Fixed 0.6V VREF
- A/D Converter:
  - 10-bit resolution and 12 channels
- Timer0: 8-bit timer/counter with 8-bit programmable prescaler
- Enhanced Timer1:
  - 16-bit timer/counter with prescaler
  - External Timer1 Gate (count enable)
  - Option to use OSC1 and OSC2 in LP mode as Timer1 oscillator if INTOSC mode selected
- Timer2: 8-bit timer/counter with 8-bit period register, prescaler and postscaler
- Enhanced Capture, Compare, PWM+ module:
  - 16-bit Capture, max resolution 12.5 ns
  - Compare, max resolution 200 ns
  - 10-bit PWM with 1, 2 or 4 output channels, programmable "dead time", max frequency 20 kHz
  - PWM output steering control
- Synchronous Serial Port (SSP):
  - SPI mode (Master and Slave)
- I<sup>2</sup>C™ (Master/Slave modes):
  - I<sup>2</sup>C™ address mask
- In-Circuit Serial Programming™ (ICSP™) via two pins

# PIC16F631/677/685/687/689/690

Device	Program Memory	Data Memory		I/O	10-bit A/D (ch)	Comparators	Timers 8/16-bit	SSP	ECCP+	EUSART
	Flash (words)	SRAM (bytes)	EEPROM (bytes)							
PIC16F631	1024	64	128	18	—	2	1/1	No	No	No
PIC16F677	2048	128	256	18	12	2	1/1	Yes	No	No
PIC16F685	4096	256	256	18	12	2	2/1	No	Yes	No
PIC16F687	2048	128	256	18	12	2	1/1	Yes	No	Yes
PIC16F689	4096	256	256	18	12	2	1/1	Yes	No	Yes
PIC16F690	4096	256	256	18	12	2	2/1	Yes	Yes	Yes

## PIC16F631 Pin Diagram

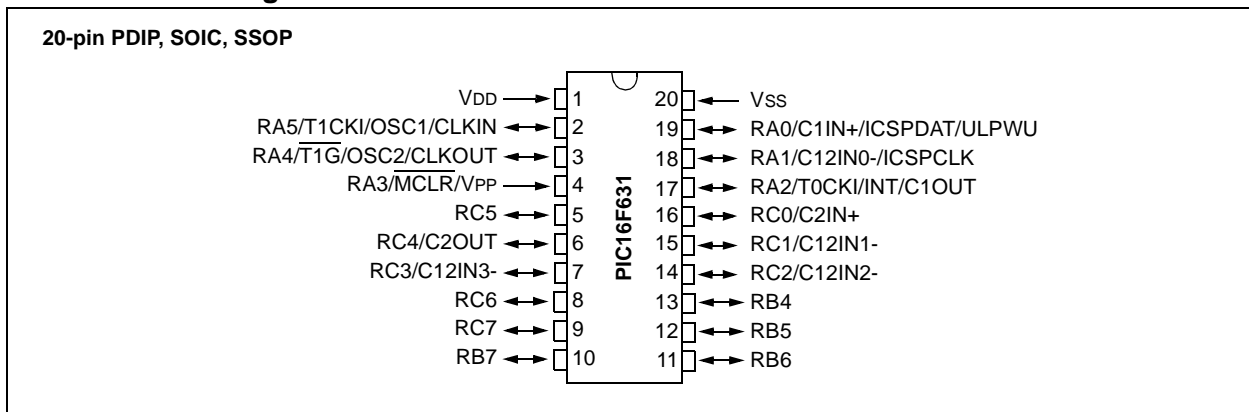

TABLE 1: PIC16F631 PIN SUMMARY

I/O	Pin	Analog	Comparators	Timers	Interrupt	Pull-up	Basic
RA0	19	AN0/ULPWU	C1IN+	—	IOC	Y	ICSPDAT
RA1	18	AN1	C12IN0-	—	IOC	Y	ICSPCLK
RA2	17	—	C1OUT	T0CKI	IOC/INT	Y	—
RA3	4	—	—	—	IOC	Y <sup>(1)</sup>	MCLR/VPP
RA4	3	—	—	T1G	IOC	Y	OSC2/CLKOUT
RA5	2	—	—	T1CKI	IOC	Y	OSC1/CLKIN
RB4	13	—	—	—	IOC	Y	—
RB5	12	—	—	—	IOC	Y	—
RB6	11	—	—	—	IOC	Y	—
RB7	10	—	—	—	IOC	Y	—
RC0	16	AN4	C2IN+	—	—	—	—
RC1	15	AN5	C12IN1-	—	—	—	—
RC2	14	AN6	C12IN2-	—	—	—	—
RC3	7	AN7	C12IN3-	—	—	—	—
RC4	6	—	C2OUT	—	—	—	—
RC5	5	—	—	—	—	—	—
RC6	8	—	—	—	—	—	—
RC7	9	—	—	—	—	—	—
—	1	—	—	—	—	—	VDD
—	20	—	—	—	—	—	VSS

Note 1: Pull-up enabled only with external MCLR configuration.

# PIC16F631/677/685/687/689/690

## PIC16F677 Pin Diagram

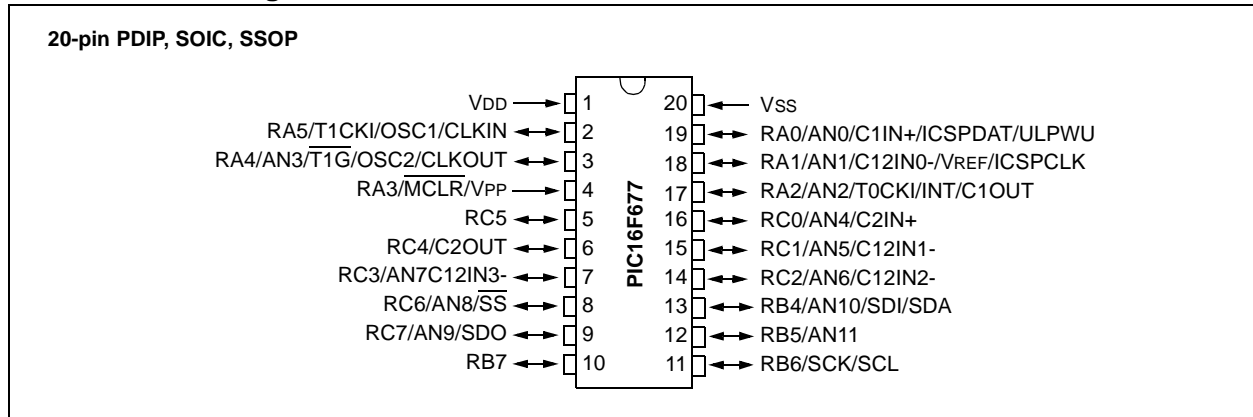

**TABLE 2: PIC16F677 PIN SUMMARY**

I/O	Pin	Analog	Comparators	Timers	SSP	Interrupt	Pull-up	Basic
RA0	19	AN0/ULPWU	C1IN+	—	—	IOC	Y	ICSPDAT
RA1	18	AN1/VREF	C12IN0-	—	—	IOC	Y	ICSPCLK
RA2	17	AN2	C1OUT	T0CKI	—	IOC/INT	Y	—
RA3	4	—	—	—	—	IOC	Y <sup>(1)</sup>	MCLR/VPP
RA4	3	AN3	—	T1G	—	IOC	Y	OSC2/CLKOUT
RA5	2	—	—	T1CKI	—	IOC	Y	OSC1/CLKIN
RB4	13	AN10	—	—	SDI/SDA	IOC	Y	—
RB5	12	AN11	—	—	—	IOC	Y	—
RB6	11	—	—	—	SCL/SCK	IOC	Y	—
RB7	10	—	—	—	—	IOC	Y	—
RC0	16	AN4	C2IN+	—	—	—	—	—
RC1	15	AN5	C12IN1-	—	—	—	—	—
RC2	14	AN6	C12IN2-	—	—	—	—	—
RC3	7	AN7	C12IN3-	—	—	—	—	—
RC4	6	—	C2OUT	—	—	—	—	—
RC5	5	—	—	—	—	—	—	—
RC6	8	AN8	—	—	SS	—	—	—
RC7	9	AN9	—	—	SDO	—	—	—
—	1	—	—	—	—	—	—	VDD
—	20	—	—	—	—	—	—	VSS

**Note 1:** Pull-up activated only with external MCLR configuration.

# PIC16F631/677/685/687/689/690

## PIC16F685 Pin Diagram

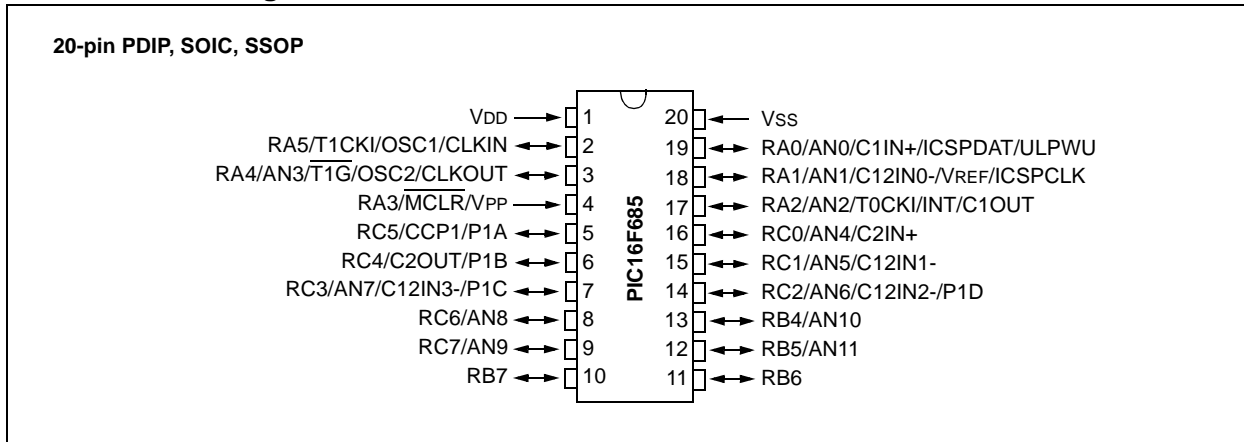

TABLE 3: PIC16F685 PIN SUMMARY

I/O	Pin	Analog	Comparators	Timers	ECCP	Interrupt	Pull-up	Basic
RA0	19	AN0/ULPWU	C1IN+	—	—	IOC	Y	ICSPDAT
RA1	18	AN1/VREF	C12IN0-	—	—	IOC	Y	ICSPCLK
RA2	17	AN2	C1OUT	T0CKI	—	IOC/INT	Y	—
RA3	4	—	—	—	—	IOC	Y <sup>(1)</sup>	MCLR/VPP
RA4	3	AN3	—	T1G	—	IOC	Y	OSC2/CLKOUT
RA5	2	—	—	T1CKI	—	IOC	Y	OSC1/CLKIN
RB4	13	AN10	—	—	—	IOC	Y	—
RB5	12	AN11	—	—	—	IOC	Y	—
RB6	11	—	—	—	—	IOC	Y	—
RB7	10	—	—	—	—	IOC	Y	—
RC0	16	AN4	C2IN+	—	—	—	—	—
RC1	15	AN5	C12IN1-	—	—	—	—	—
RC2	14	AN6	C12IN2-	—	P1D	—	—	—
RC3	7	AN7	C12IN3-	—	P1C	—	—	—
RC4	6	—	C2OUT	—	P1B	—	—	—
RC5	5	—	—	—	CCP1/P1A	—	—	—
RC6	8	AN8	—	—	—	—	—	—
RC7	9	AN9	—	—	—	—	—	—
—	1	—	—	—	—	—	—	VDD
—	20	—	—	—	—	—	—	VSS

Note 1: Pull-up activated only with external MCLR configuration.

# PIC16F631/677/685/687/689/690

## PIC16F687/689 Pin Diagram

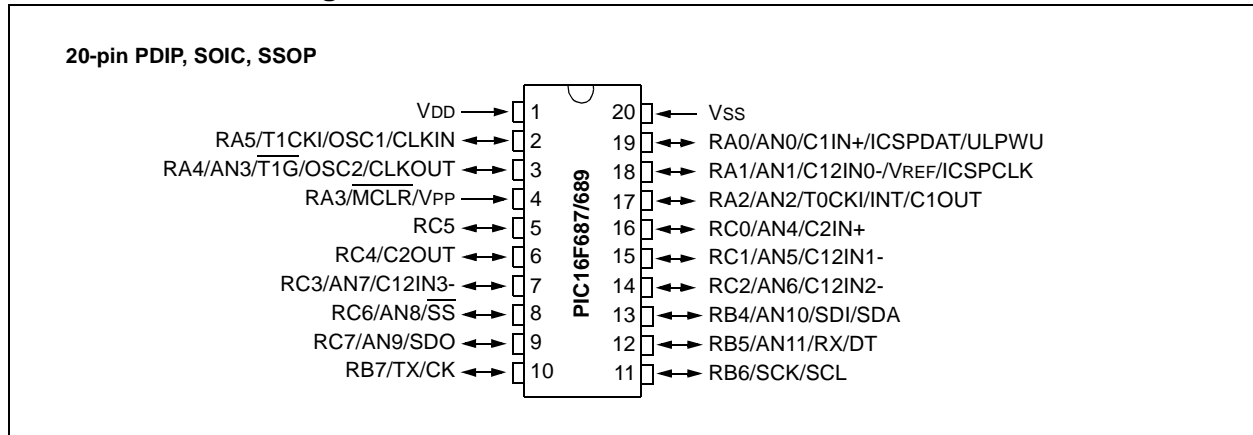

TABLE 4: PIC16F687/689 PIN SUMMARY

I/O	Pin	Analog	Comparators	Timers	EUSART	SSP	Interrupt	Pull-up	Basic
RA0	19	AN0/ULPWU	C1IN+	—	—	—	IOC	Y	ICSPDAT
RA1	18	AN1/VREF	C12IN0-	—	—	—	IOC	Y	ICSPCLK
RA2	17	AN2	C1OUT	T0CKI	—	—	IOC/INT	Y	—
RA3	4	—	—	—	—	—	IOC	Y <sup>(1)</sup>	$\overline{\text{MCLR}}/\text{VPP}$
RA4	3	AN3	—	$\overline{\text{T1G}}$	—	—	IOC	Y	OSC2/CLKOUT
RA5	2	—	—	T1CKI	—	—	IOC	Y	OSC1/CLKIN
RB4	13	AN10	—	—	—	SDI/SDA	IOC	Y	—
RB5	12	AN11	—	—	RX/DT	—	IOC	Y	—
RB6	11	—	—	—	—	SCL/SCK	IOC	Y	—
RB7	10	—	—	—	TX/CK	—	IOC	Y	—
RC0	16	AN4	C2IN+	—	—	—	—	—	—
RC1	15	AN5	C12IN1-	—	—	—	—	—	—
RC2	14	AN6	C12IN2-	—	—	—	—	—	—
RC3	7	AN7	C12IN3-	—	—	—	—	—	—
RC4	6	—	C2OUT	—	—	—	—	—	—
RC5	5	—	—	—	—	—	—	—	—
RC6	8	AN8	—	—	—	$\overline{\text{SS}}$	—	—	—
RC7	9	AN9	—	—	—	SDO	—	—	—
—	1	—	—	—	—	—	—	—	VDD
—	20	—	—	—	—	—	—	—	VSS

**Note 1:** Pull-up activated only with external  $\overline{\text{MCLR}}$  configuration.

# PIC16F631/677/685/687/689/690

## PIC16F690 Pin Diagram (PDIP, SOIC, SSOP)

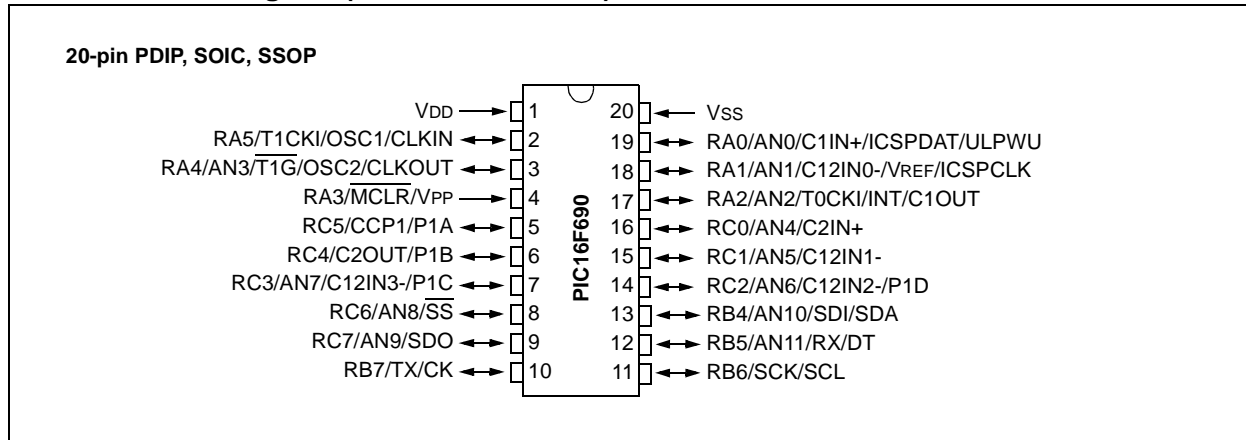

**TABLE 5: PIC16F690 PIN SUMMARY**

I/O	Pin	Analog	Comparators	Timers	ECCP	EUSART	SSP	Interrupt	Pull-up	Basic
RA0	19	AN0/ULPWU	C1IN+	—	—	—	—	IOC	Y	ICSPDAT
RA1	18	AN1/VREF	C12IN0-	—	—	—	—	IOC	Y	ICSPCLK
RA2	17	AN2	C1OUT	T0CKI	—	—	—	IOC/INT	Y	—
RA3	4	—	—	—	—	—	—	IOC	Y <sup>(1)</sup>	MCLR/VPP
RA4	3	AN3	—	T1G	—	—	—	IOC	Y	OSC2/CLKOUT
RA5	2	—	—	T1CKI	—	—	—	IOC	Y	OSC1/CLKIN
RB4	13	AN10	—	—	—	—	SDI/SDA	IOC	Y	—
RB5	12	AN11	—	—	—	RX/DT	—	IOC	Y	—
RB6	11	—	—	—	—	—	SCL/SCK	IOC	Y	—
RB7	10	—	—	—	—	TX/CK	—	IOC	Y	—
RC0	16	AN4	C2IN+	—	—	—	—	—	—	—
RC1	15	AN5	C12IN1-	—	—	—	—	—	—	—
RC2	14	AN6	C12IN2-	—	P1D	—	—	—	—	—
RC3	7	AN7	C12IN3-	—	P1C	—	—	—	—	—
RC4	6	—	C2OUT	—	P1B	—	—	—	—	—
RC5	5	—	—	—	CCP1/P1A	—	—	—	—	—
RC6	8	AN8	—	—	—	—	SS	—	—	—
RC7	9	AN9	—	—	—	—	SDO	—	—	—
—	1	—	—	—	—	—	—	—	—	VDD
—	20	—	—	—	—	—	—	—	—	VSS

**Note 1:** Pull-up activated only with external MCLR configuration.



# PIC16F631/677/685/687/689/690

## PIC16F690 Pin Diagram (QFN)

20-pin QFN

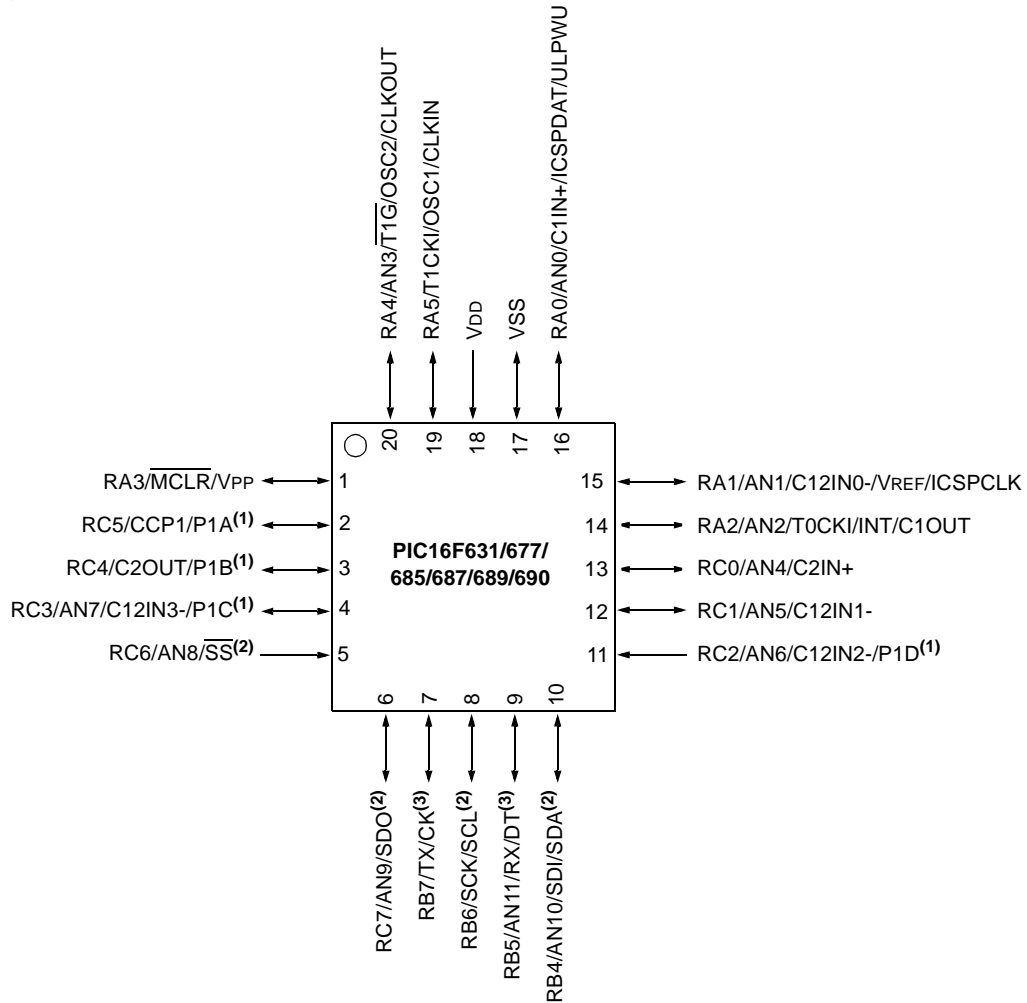

- Note 1:** CCP1/P1A, P1B, P1C and P1D are available on PIC16F685/PIC16F690 only.
- Note 2:** SS, SDO, SDI/SDA and SCL/SCK are available on PIC16F677/PIC16F687/PIC16F689/PIC16F690 only.
- Note 3:** RX/DT and TX/CK are available on PIC16F687/PIC16F689/PIC16F690 only.