

Solid State Power Relays

Model R2025

FEATURES

- CSA certified file #LR701222
- 100% functionally and surge tested
- 24 to 330 VAC load voltage
- 4000 V isolation
- Optically coupled
- Epoxy filled
- Capable of being switched by a single CMOS gate
- Built in snubber
- Capable of switching inductive loads of 0.5 power factor
- UL recognized component file #E164906

The AMETEK NCC Series of Solid State Power Relays provide a highly reliable means of switching a variety of AC loads up to 20 A. Snubber circuitry is included with each unit for high dV/dt applications and inductive loads.

Use of rugged output devices provides significant increases in turn-on surge capability. Two input control voltage ranges are available in either Form A (SPST-NO) or Form B (SPST-NC) output configurations.

SPECIFICATIONS

ALL MODELS

- Max. Load Current*:** 25 A
- Max. Peak Transient Voltage:** 600 Vpk
- Output Voltage Range:** 48-300 VAC
- Max. Off State Leakage Current:** 7.2 mA at 300 VAC (RMS)
- Operating Temp. Range:** -40 to 80 °C
- Storage Temp. Range:** -40 to 65 °C
- Dielectric Strength at 60 Hz**
Between Input/Output: 4000 VAC (RMS)
Between Input/Base: 2500 VAC (RMS)
Between Output/Base: 2500 VAC (RMS)
- Max. Surge Current:** 370 arms, 8.3 ms
- Min. Off State dV/dt (static):** 500 V/μS
- Thermal Resistance Junction to Case (Point A):** 1.3°C/W Tj max.=110 °C
- Turn On Type:** Random
- SNC-R2025-507 AND SNC-R2025-517**
- Max. On State Voltage Drop:** 1.5 VAC (RMS)
- Input Impedance:** 1700 ohms ±5%
- Turn Off Voltage:** 2 VAC/DC min.
- Turn On Voltage:** 3 VAC/DC max.
- Output Form:**
SNC-R2025-507: SPST-NO
SNC-R2025-517: SPST-NC
- Control Voltage Range:** 3-30 VAC/DC
- SNC-R2025-501 AND SNC-R2025-511**
- Max. On State Voltage Drop:** 1.65 VAC (RMS)
- Input Impedance:** 56 Kohms ±5%
- Turn Off Voltage:** 30 VAC/DC min.
- Turn On Voltage:** 70 VAC/DC max.
- Output Form:**
SNC-R2025-501: SPST-NO
SNC-R2025-511: SPST-NC
- Control Voltage Range:** 70-140 VAC/DC

* See derating curves for proper heat sink requirements

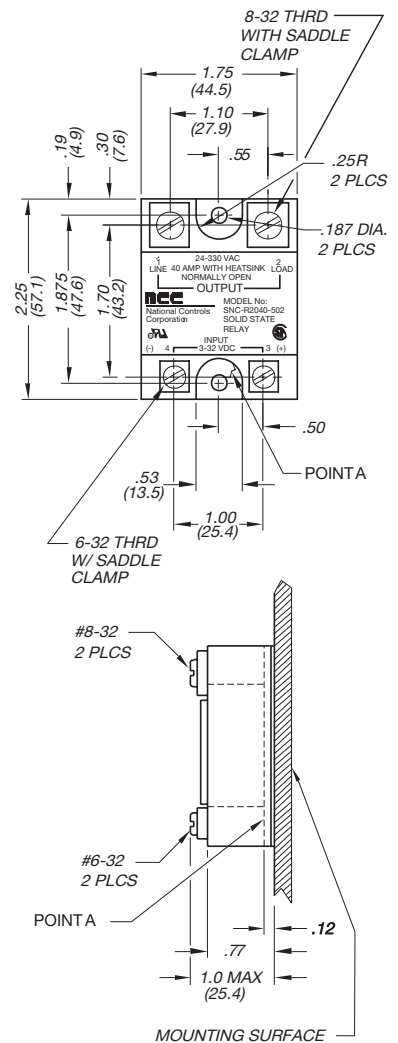
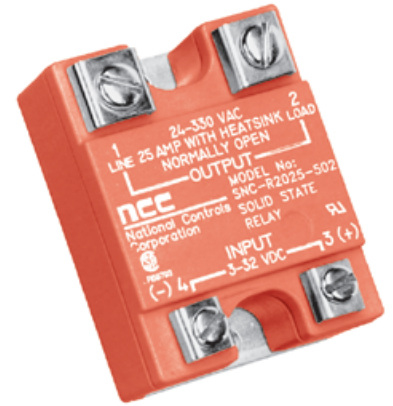

ORDERING INFORMATION

INPUT VOLTAGE	OUTPUT CONFIGURATION	PART NUMBER
3 to 30 VAC/DC	Normally Open, 25 A	SNC-R2025-507
7 to 140 VAC	Normally Open, 25 A	SNC-R2025-501
3 to 30 VAC/DC	Normally Closed, 25 A	SNC-R2025-517
7 to 140 VAC	Normally Closed, 25 A	SNC-R2025-511

ACCESSORY	PART NUMBER
Heatsink, .9 °C/W, supplied with Thermal Compound and Mounting Hardware	ASY-HS25A-011

Heat Sink Data

Heat sinks for derating curves are 1/8" thick aluminum with thermal compound between the mounting surface and solid state relay mounting plate.

