



**Product Type**  
Thermal Circuit Breaker

**Product Series**  
CLB-Series

**Description**  
[CLB-Series PDF eLibrary](#) ↓

The CLB-Series is a compact, single pole, push-to-reset family of thermal circuit breakers designed to protect equipment. The CLB-Series of thermal breakers are slightly larger than the CMB-Series, with longer bushings and broader amp rating range.

Utilizing simple, precision design with few moving parts, these breakers offer cost effective, extremely reliable circuit protection with high resistance against shock and vibration. The CLB -Series provides a consistent trip point over temperatures ranging from -10°C to +60°C. They are ideally suited for such applications as household and commercial appliances, transportation, marine, telecommunications, power strips, audio-visual, medical, and power supplies.

<b>Series PDF eLibrary</b>	<ul style="list-style-type: none"> <li><a href="#">CLB-Series Thermal Cir. Breaker PDF (176.6 KB)</a></li> </ul>
<b>Certifications</b>	UL, CUL, TUV, CE, UL1500/ISO8846 for ignition protection
<b>Number of Poles</b>	1 pole
<b>Maximum Current and Voltage Ratings</b>	3 - 40 amps @ 125-250VAC, 32VDC
<b>Maximum Interrupting Capacity</b>	1,000 amps
<b>Available Circuits</b>	Series Trip
<b>Actuator Style</b>	Push to reset button
<b>Terminal Options</b>	.250 Quick Connect Tabs .250 Quick Connect Tabs with 90-degree bend Screw Terminal
<b>Mounting Method</b>	Front Panel Front Panel Snap-in

# Thermal Circuit Protectors

*Reliable, Cost-effective Circuit Protection*



Any electrical or electronic equipment that is designed without including circuit protection is an accident waiting to happen. Under normal operating conditions, this may not appear to be a problem. However, normal operating conditions are not always guaranteed. Under strained or heavy use, a motor and/or another load-generating component within the equipment will draw additional current from the power source; when this happens, the equipment's wires and/or components will overheat and may ultimately burn up. Also, power surges and short circuits in unprotected equipment can cause extensive damage to the equipment and to the conductors leading to the equipment.

In addition to protecting the equipment, the entire electrical system including the control switches, wires, and power source must be protected from faults. A circuit protection device should be employed at any point where a conductor size changes. Many electronic circuits and components like transformers have a lower overload withstand threshold level than conductors such as wires and cables. These components require circuit protection devices featuring very fast overload sensing and opening capabilities.

Specifying a circuit protection device for an application is not a difficult task, but it will require some thought. If electrical and electronic equipment is designed with over-specified circuit protection devices they will be vulnerable to the damaging effects of power surges and the catastrophic results of a fire; while using under-specified circuit protection devices will result in nuisance tripping.

The short circuit capacity of a circuit protection device should be greater than the circuit's available short circuit fault current. Available short circuit current is the maximum RMS current that would be present if all the conductors were to be connected directly to the fault location. In reality, this is not the case. The actual short circuit current is much less than the available short circuit current. The actual short circuit current is reduced due to the combined impedance of the conductors, the size of the transformer and other current restricting components within the circuit.

The application's environmental conditions must be considered when selecting the proper circuit protection device. Excessive temperature, humidity, severe vibration and shock can cause adverse performance characteristics in many types of circuit protection devices. For instance, a fuse element is less reliable when it is hot than when it is cold.

---

### Available Choices of Circuit Protection

Carling Technologies offers three types of circuit protection devices: thermal circuit protectors, hydraulic/magnetic circuit protectors/breakers and equipment leakage circuit breakers. This catalog features our thermal circuit protection product line. For details related to hydraulic/magnetic circuit protection and equipment leakage circuit breaker products, please see our Circuit Protection 403 catalog.

Thermal circuit protectors utilize a bimetallic strip electrically in series with the circuit. The heat generated by the current during an overload deforms the bimetallic strip and trips the breaker. Thermal protectors have a significant advantage over fuses in that they can be reset after tripping. They can also be used as the main ON/OFF switch for the equipment being protected.

Hydraulic/magnetic circuit protectors/breakers provide highly precise, reliable and cost effective solutions to most design problems. The hydraulic/magnetic circuit breaker is considered to be temperature stable and thus is not appreciably affected by changes in ambient temperature. Its over-current sensing mechanism reacts only to changes of current in the circuit being protected. It has no "warm-up" period to slow down its response to overload. It has no "cool-down" period after overload before it can be reset. The characteristics of a

hydraulic/magnetic circuit breaker can be tailored in four separate areas: the desired circuit; the trip point (in amperes); the time delay (in seconds); and the inrush handling capacity of the breaker. These factors can be varied with relatively little impact on the short circuit capability of the breaker. Typically, hydraulic/magnetic circuit breakers are available with a choice of three different trip time, delay curves: slow, medium and long. These choices provide the designer with a high level of design flexibility when matching the breakers trip time delay curves to other circuit protection devices in a cascade, or discriminating circuit. In addition, special hi-inrush constructions are available for equipment with severe inrush characteristics.

Equipment leakage circuit breakers function as hydraulic/magnetic circuit breakers, offering customized overload and short circuit protection. In addition, they sense and guard against faults to ground using innovative electronics technologies. With the exception of small amounts of leakage, the current returning to the power supply will be equal to the current leaving the power supply. If the difference between the current leaving and returning through the earth leakage circuit breaker exceeds the leakage sensitivity setting, the breaker trips and its LED illuminates. The LED gives a clear indication that the trip occurred as a result of leakage to ground. This protection helps prevent serious equipment damage and fire.



**Rating:**  
3 to 60A, 125-250VAC, 32VDC

**Approvals:**  
*UL, CUL, CSA, TUV, CE*  
*UL1500/ISO8846 for ignition protection/marine*

**Dielectric Strength:**  
2500 VAC/ 1 minute

**Interrupting capacity:**  
2500 amps

**Insulation Resistance:**  
100M ohms

**Operating Temperature:**  
-10°C to 60°C

**Voltage drop:**  
< 0.25 V

**Applications:**  
Household Appliances  
Transportation  
Marine  
Power Strips  
Medical Equipment  
Audio Visual Equipment  
Power Supplies

**ROHS Compliant**

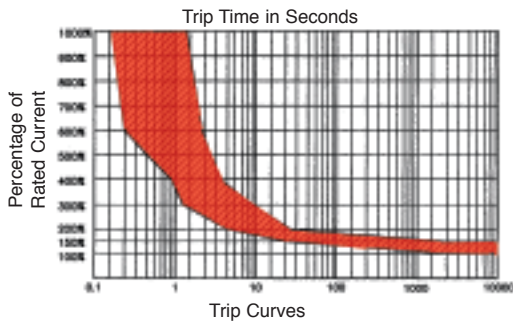

CORRECTION FACTOR <sup>1</sup>	
0°C	x .67
10°C	x .72
15°C	x .83
18°C	x .87
25°C	x 1.00
32°C	x 1.05
40°C	x 1.18
50°C	x 1.33
60°C	x 1.67

OVERLOAD	TRIP TIME
100%	NO TRIP
150%	TRIP IN 1 HR.
200%	5 - 35 SEC.
300%	1.5- 9 SEC.
400%	0.9 - 5.5 SEC.
500%	0.5 - 3.5 SEC.
600%	0.3 - 2.8 SEC.

Breaker must hold 100% of rated current and must trip at 150% and above, within the time limits shown in curve. Trip times specified at 25° ambient with no preloading.  
 1 To adjust the breaker rating for ambient temperature multiply the breaker rating by the factor. (ex: 5 amp rating at 0°C: 5 x .67 = 3.3 amp. Select 3 amp rating.)

### 3-40A Construction

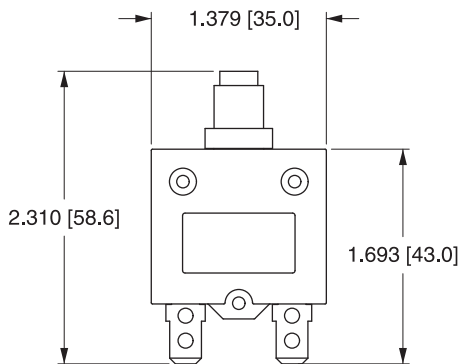

### 50 & 60A Construction

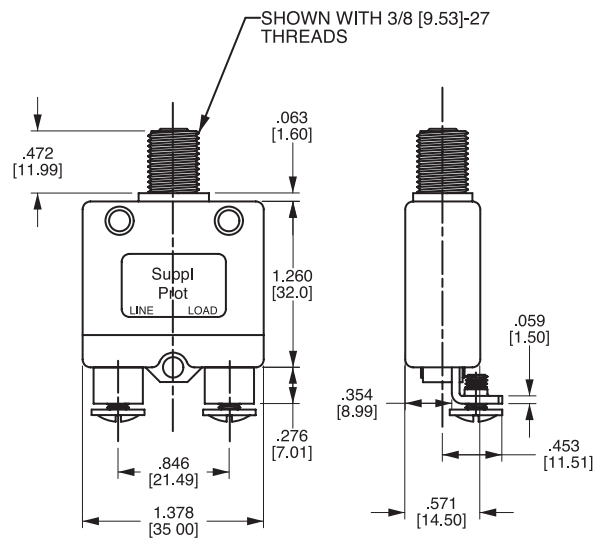

Ordering Scheme

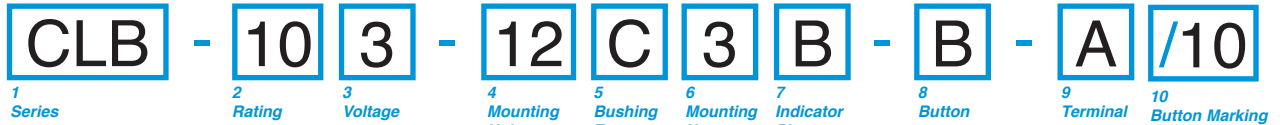

**1 SERIES**  
CLB

**2 RATING<sup>10</sup>**

03 3 amp	05 5 amp	07 7 amp	10 10 amp	13 13 amp	18 18 amp	25 25 amp	35 35 amp	<b>NEW</b> 50 <sup>12</sup> 50 amp 60 <sup>12</sup> 60 amp
04 4 amp	06 6 amp	08 8 amp	12 12 amp	15 15 amp	20 20 amp	30 30 amp	40 40 amp	

**3 VOLTAGE**  
3 125-250VAC/ 32 VDC

**4 MOUNTING HOLE**

11 <sup>1</sup> M11 12 <sup>2</sup> M12 00 <sup>3</sup> Snap In 27 <sup>4</sup> 3/8 " 27 UNS			Panel Cutout Thickness: [0.8] - [2.5]mm .623 [15.8] diameter .544 [13.8] width .008 to .020 height	
	M 11	M12	Snap-in Style	3/8-27 UNS

**5 BUSHING**

	METAL				PLASTIC	
<b>METAL</b> A <sup>5</sup> Type A B <sup>6</sup> Type B J <sup>8</sup> Type J <b>PLASTIC</b> C <sup>5</sup> Type C D <sup>7</sup> Type D E <sup>8</sup> Type E						
	TYPE A	TYPE B	TYPE J	TYPE C	TYPE D	TYPE E

**6 MOUNTING NUT<sup>9</sup>**

	METAL	METAL PAL	PLASTIC	HEX BOOT
N None      5 Type 5 1 Type 1      6 <sup>12,15</sup> Type 6 2 Type 2      7 <sup>12</sup> Type 7 3 Type 3      8 <sup>12</sup> Type 8 4 Type 4				
	TYPE 1	TYPE 2 / TYPE 6	TYPE 3	TYPE 5 / TYPE 8

NOTE: Type 5 is clear hex boot. Type 8 is black hex boot (available for bushings E & J only); Type 3 nut includes molded in "PRESS TO RESET" marking.

**7 INDICATOR PLATE<sup>9</sup>**

N None A Embossed B Silver Printing on Black		
----------------------------------------------------	--	--

All indicator plates are marked "circuit breaker press to reset".

**NOTES:**  
 All dimensions are in. [mm].  
 Tolerance ±.005 [.127] unless otherwise specified.  
 1 Used with bushing C or B only.  
 2 Used with bushing C only.  
 3 Used with bushing D only.  
 4 Used with bushing E & J only.  
 5 Used with M12 mounting hole only.  
 6 Used with M11 mounting hole only.  
 7 Used with mounting hole 00 only.  
 8 Used with 27 mounting hole only.  
 9 All hardware available separately. Consult factory.  
 10 > 35 amp ratings must use solder joint to connect wire to non-screw type terminals.  
 11 Terminals are .040 [1.0] thickness for rating > 35, & .315 [8] thickness is for ratings < 35 amps.  
 12 Available with type E or J bushing only.  
 13 Available only with 10-24 unc. screw terms. (select type F, G, H, J only.)  
 14 Amp rating must match button marking (ex: "20" will be marked on the button of the CLB-203-27E3N-B-A/20)  
 15 Thickness is 3.0 mm, .118 in.

**8 BUTTON**

B Black	R Red	W White
---------	-------	---------

**9 TERMINAL<sup>10,11</sup>**

A Type A B Type B C Type C D Type D E Type E F Type F G Type G H Type H J Type J									
	.250 Tab	.250 Tab	.250 Tab	.250 Tab	.250 Tab	.250 Tab	.250 Tab	.250 Tab	.250 Tab
	Type A: Straight	Type B: Line Pin	Type C: Load Pin	Type D: 90° Bend	Type E: 90° Bend Backward	Type F: Screw Terminal	Type G: Mixed Terminals 90° Bend Load	Type H: Screw Terminal 90° Bend	Type J: Screw Terminal 90° Bend

**10 BUTTON MARKING<sup>14</sup> (IF BLANK, NO MARKING.)** Button Marking Orientation:

line	(15)	load
03 3 amp	05 5 amp	07 7 amp
04 4 amp	06 6 amp	08 8 amp
10 10 amp	12 12 amp	13 13 amp
15 15 amp	18 18 amp	20 20 amp
25 25 amp	30 30 amp	35 35 amp
40 40 amp	50 50 amp	60 60 amp

Most countries have regulatory agencies that determine the safety and performance standards required for products used in that country. Carling Technologies' circuit breakers are tested and have been certified by the most widely recognized of these agencies including Underwriters Laboratories (UL) in the United States; Canadian Standards Association (CSA) in Canada; TUV Rheinland/Berlin-Brandenburg (TUV) and Verband Deutscher Elektrotechniker (VDE) in Germany.

#### **UL Recognized/UL1077 Recognized**

UL Recognition covers components, which are incomplete or restricted in performance capabilities. These components will later be used in complete end products or systems Listed by UL. These Recognized components are not intended for separate installation in the field, they are intended for use as components of complete equipment submitted for investigation to UL.

Carling Technologies offers circuit breakers which are classified as supplementary circuit protectors and are Recognized under the UL Components Recognition Program as Protectors, Supplementary, UL Standard 1077. A UL 1077 Recognized supplementary circuit protector must have a Listed overcurrent device as a "back up".

#### **UL Listed/UL 489 Listed**

UL Listing indicates that samples of the circuit breaker as a complete product have been tested by UL to nationally recognized safety standards and have been found to be free from reasonably foreseeable risks of fire, electric shock and related hazards, and that the product was manufactured under UL's Follow-Up Services program.

Carling Technologies offers branch circuit breakers that are UL 489 Listed. Branch circuit breakers are classified as a final overcurrent device dedicated to protecting the branch circuit and outlet(s). They do not require an additional "back up" overcurrent device wired in series to protect a circuit. Carling's C, E and F-Series circuit breakers offer UL489 Listing. In addition, they are UL489A Listed for the Telecom industry.

#### **UL1500 (MARINE)**

UL1500 refers to products and components classified as ignition-protected, and are intended to be installed and used in accordance with applicable requirements to the U.S. Coast Guard, the Fire Protection Standard for Pleasure and Commercial Motor Craft, ANSI/NFPA No. 302, and the American Boat and Yacht Council, Incorporated.

#### **CSA**

The CSA (Canadian Standards Association) is the closest in concept and nature to UL of any group outside of the United States. Their standards and requirements are often almost identical to corresponding UL standards. CSA publishes their standards for most circuit protection devices as separate sections of CSA Standard C22.2 that in turn, forms a part of the Canadian Electrical Code.

#### **CUL**

A CUL mark on a product means that samples of the product have been evaluated to the applicable Canadian standards and codes by Underwriters Laboratories Inc.

#### **VDE and TUV**

There are two German government approved independent agencies, VDE (Verband Deutscher Elektrotechniker), and TUV (Technischer Überwachungs-Verein). In the circuit protection field, outside of the U.S.A. and Canada, VDE is the best known certification mark. VDE testing facilities are located in Germany.

TUV also performs testing and grants certification in accordance to the IEC/EN specifications. TUV's organization is made up of at least eleven geographically dispersed companies. At least two are located in the United States. This aids some U.S. manufacturers in getting "fast track" approval to a IEC/EN specifications.

#### **CE MARKING**

The European Union's (EU) approach to create single market access is based on four principles: harmonized directives, harmonized standards, harmonized conformity assessment procedures and CE marking. The CE marking is affixed to products indicating that the product conforms to relevant directives and standards. Various directives and standards contain the requirements for the CE marking. The CE marking is primarily for market control by custom inspectors.

Before a manufacturer can affix the CE marking to their product they must complete the following steps:

1. Identify the applicable EU directive/standard
2. Perform the conformity assessment according to the applicable EU directive/standard
3. Establish a Technical File containing test reports, documentation, certificates, etc.
4. Prepare and sign a EU Declaration of Conformity

Many of Carling Technologies' circuit protection products are available with CE marking indicating conformance to Low Voltage Directive 73/23/EEC.