

# General Purpose Relay

# MJN

## Relay with Plug-in Termination, available in SPDT, DPDT or 3PDT models

- Rugged power driver offers superior 3/16" through-air and 3/8 over-surface spacing
- Interlocked frame and contact block prevent contact misalignment during plug-in
- Available with dust covers, indicator lamps and push-to-operate buttons
- UL and CSA recognition as motor controllers up to 600 VAC
- Recognized for 1/2 hp motor control applications at 240/480/600 VAC (1/3 hp at 120 VAC)



## Ordering Information

To Order: Select part number and add the desired coil voltage rating (e.g. MJN1C-AC24).

Item			Model			
Type	Terminal	Contact form	10A Version, flange mounting	20 A Version, flange mounting	30A Version, flange mounting	10 A Relay only
Standard	Plug-in	SPDT	MJN1CF	---	MJN1Z-E-RP	MJN1C
		DPDT	MJN2CF	MJN2CE	---	MJN2C
		3PDT	MJN3CF	---	---	MJN3C
LED indicator	Plug-in	SPDT	MJN1CF-N*	---	---	MJN1C-N
		DPDT	MJN2CF-N*	---	---	MJN2C-N
		3PDT	MJN3CF-N*	---	---	MJN3C-N
Push-to-operate button	Plug-in	SPDT	MJN1CF-I*	---	---	MJN1C-I
		DPDT	MJN2CF-I*	---	---	MJN2C-I
		3PDT	MJN3CF-I*	---	---	MJN3C-I
Push-to-operate button & LED indicator	Plug-in	SPDT	MJN1CF-IN*	---	---	MJN1C-IN
		DPDT	MJN2CF-IN*	---	---	MJN2C-IN
		3PDT	MJN3CF-IN*	---	---	MJN3C-IN
Latching	Plug-in	DPDT	---	---	---	MJN2CK

**Note:** All part numbers marked with an "\*" are non-standard parts. Contact an Omron representative for additional information.

# Specifications

## ■ Contact Data

<b>Configuration</b>		SPDT, DPDT, 3PDT
<b>Initial contact resistance</b>		50 mΩ max.
<b>Materials</b>		3/16" diameter Ag-Alloy
<b>Contact UL ratings</b>	<b>10 A</b>	10 amp @ 28 VDC and 120/240 VAC at 80% pf, 1/3 hp @ 120 VAC, 1/2 hp @ 277/240/480/600 VAC 8.5 FLA - 36 LRA at 18 VDC, 3 amp @ 480/600 VAC at 80% pf, 10 amp @ 277 VAC resistive
	<b>20 A</b>	20 amp @28 VDC and 120/240/277 VAC, 10 amp @ 480/600 VAC, 3.4 hp @ 120 VAC, 1-1/2 hp @ 240 VAC, 17 FLA - 65 LRA at 300VAC
	<b>30 A</b>	30 amp @ 28 VDC, 15 amp @ 480 / 600 VAC, 1hp @ 120 VAC, 1-1/2 hp @ 240 VAC
<b>UL recognized file number</b>		E41643

## ■ Coil Data

### Non-latching - AC

Nominal voltage	Resistance in Ohms ± 10%		Nominal coil power		Coil voltages	Insulation resistance	Pick up voltage at 25°C (77°F)
	1 & 2 PDT	3PDT	1 & 2 PDT	3PDT			
6 VAC	6.0	4.2	1.7 VA	2.0 VA	6 to 240 VAC 50/60 Hz	1,000 MΩ min. @ 500 VDC	85% of nominal
12 VAC	21	18					
24 VAC	75	72					
120 VAC	2,250	1,700					
240 VAC	9,100	7,200					

### Non-latching - DC

Nominal voltage	Resistance in Ohms ± 10%	Nominal coil power	Coil voltages	Insulation resistance	Pick up voltage at 25°C (77°F)
5 VDC	20	1.2 W	5 to 110 VDC	1,000 MΩ min. @ 500 VDC	75% of nominal
6 VDC	32				
12 VDC	120				
24 VDC	470				
48 VDC	1,800				
110 VDC	10,000				

### Latching - AC

Nominal voltage	Latch coil resistance in Ohms ± 10%	Unlatch coil resistance in Ohms ± 10%	Nominal coil power		Coil voltages	Insulation resistance	Operate voltage (latch/unlatch) at 25°C (77°F) (see note)
6 VAC	5.5	105	1.7 VA	2.0 VA	6 to 240 VAC 50/60 Hz	1,000 MΩ min. @ 500 VDC	85% of nominal
12 VAC	22	445					
24 VAC	88	1,740					
120 VAC	2,090	17,430					

**Note:** 120% of nominal or greater (one second duration single pulse) unlatch voltage - - above this the relay latches again.  
Maximum continuous voltage: 120% of nominal (one coil only).

## Latching - DC

Nominal voltage	Latch coil resistance in Ohms $\pm 10\%$	Unlatch coil resistance in Ohms $\pm 10\%$	Nominal coil power	Coil voltages	Insulation resistance	Operate voltage (latch/unlatch) at 25°C (77°F) (see note)
5 VDC	14	45	1.2 W	5 to 110 VDC	1,000 M $\Omega$ min. @ 500 VDC	75% of nominal
6 VDC	20	64				
12 VDC	80	275				
24 VDC	330	1,070				
48 VDC	1,290	2,850				
110 VDC	5,125	10,750				

**Note:** 120% of nominal or greater (one second duration single pulse) unlatch voltage - - above this the relay latches again.  
Maximum continuous voltage: 120% of nominal (one coil only).

## ■ Characteristics

<b>Operate time</b>		15 ms nominal; 20 ms maximum	
<b>Release time</b>		6 ms nominal; 10 ms maximum	
<b>Latch time</b>		13 ms nominal with a one second pulse of nominal voltage (See note)	
<b>Unlatch time</b>		13 ms nominal with a one second pulse of nominal unlatch voltage after latching with a one second pulse of nominal latching voltage (See note)	
<b>Operating ambient temperature</b>	<b>AC: 1 &amp; 2 pole</b>	<b>Operating</b>	-45° to 60°C (-49° to 140°F)
		<b>Storage</b>	-65° to 100°C (-85° to 212°F)
	<b>AC: 3 pole</b>	<b>Operating</b>	-45° to 45°C (-49° to 113°F)
		<b>Storage</b>	-65° to 100°C (-85° to 212°F)
	<b>DC: 1, 2 &amp; 3 pole</b>	<b>Operating</b>	-45° to 70°C (-49° to 158°F)
		<b>Storage</b>	-65° to 100°C (-85° to 212°F)
<b>Insulation material</b>		High quality phenolic	
<b>Duty cycle</b>		Rated for continuous duty operation at 25% overvoltage	
<b>Shock</b>		15 g's 11 $\pm$ 1 ms (non-operating test, no mechanical damage)	
<b>Vibration</b>		0.1" DA or 10 g's, 10 to 55 Hz (operating test, no contact chatter)	
<b>Life expectancy</b>		<b>Electrical at rated load</b>	100,000 operations
		<b>Mechanical</b>	10,000,000 operations
<b>Dielectric strength</b>		Greater than 750 VAC, RMS 60 Hz across open contacts Greater than 2,500 VAC, RMS 60 Hz all other mutually insulated elements	
<b>Terminals</b>		Quick Connect	
<b>Weight</b>		64 g (2.3 oz) open relay 54 g (3.0 oz) enclosed relay	

**Note:** A latch pulse of 50 ms minimum at nominal voltage is recommended to insure positive latching.

# Terminal Arrangement

## ■ Non-Latching

Reference only

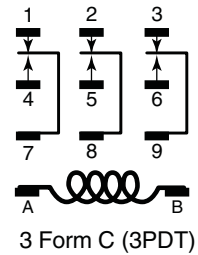
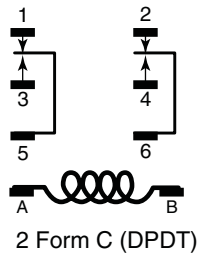
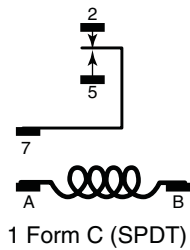

## ■ Latching / Unlatching

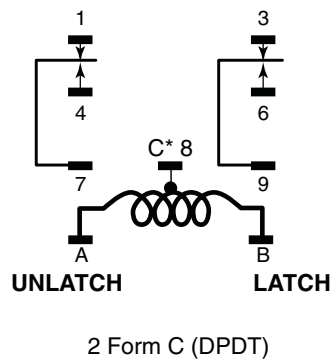
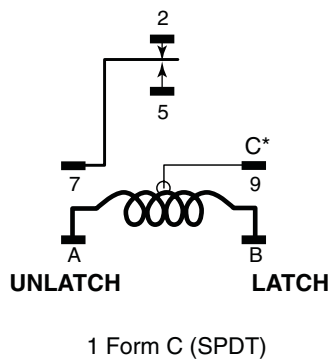

\* C denoted common connection. On 3-pole relays the common connection is a wire lead coming off of the coil. It is not terminated to the relay header. Consult your Omron representative for single coil or isolated double coil models.

# Dimensions

Unit: mm (inch)

## Relays

MJN□CF/MJN2CE

Dust cover with mounting flanges

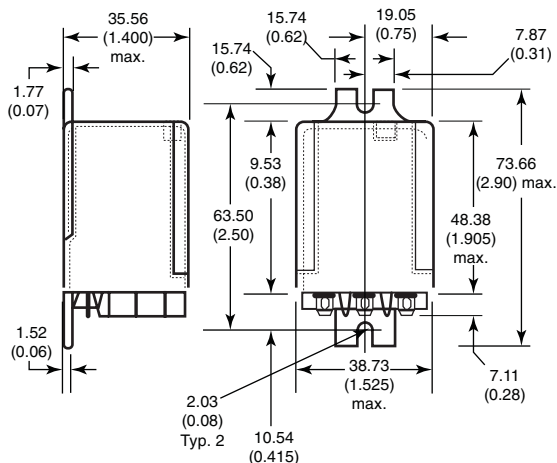

Dust cover MJN

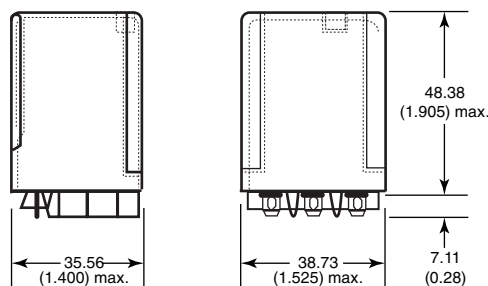

## Terminal-10 Amp Version

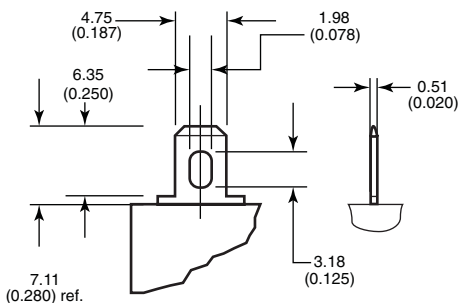

**Note:** Mates with .187" UL standard quick-connect terminals; also suitable for solder connection.

## Hold Down Springs

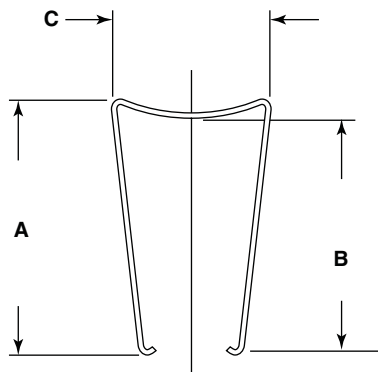

## Terminal-20 and 30 Amp Versions

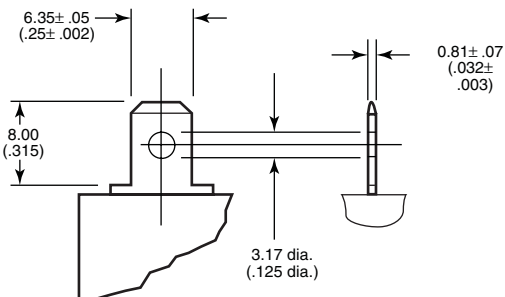

Hold Down Springs Dimensional Reference chart

Part number	Reference dimension	Actual dimension
PYMJN-PCB	A	58.67 (2.31)
	B	53.82 (2.12)
	C	37.08 (1.46)
PYMJN-S	A	58.67 (2.31)
	B	53.59 (2.11)
	C	40.26 (1.59)

■ Sockets (for use with 10 Amp, non-flange mount versions)

PTF11PC

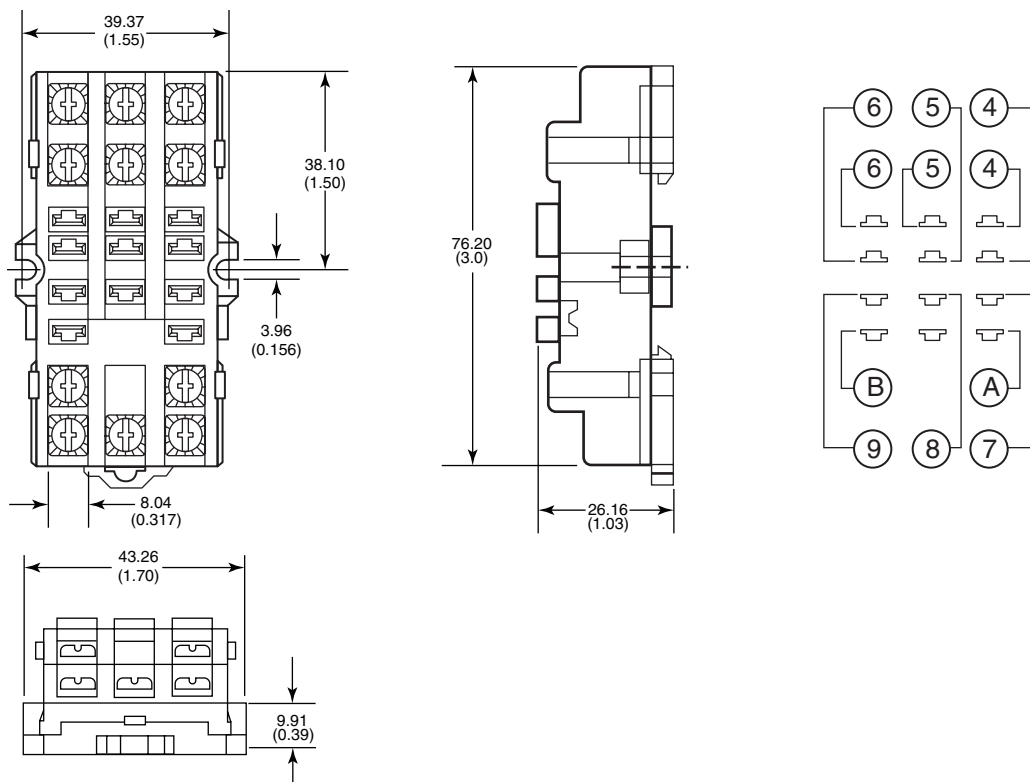

PTF21PC

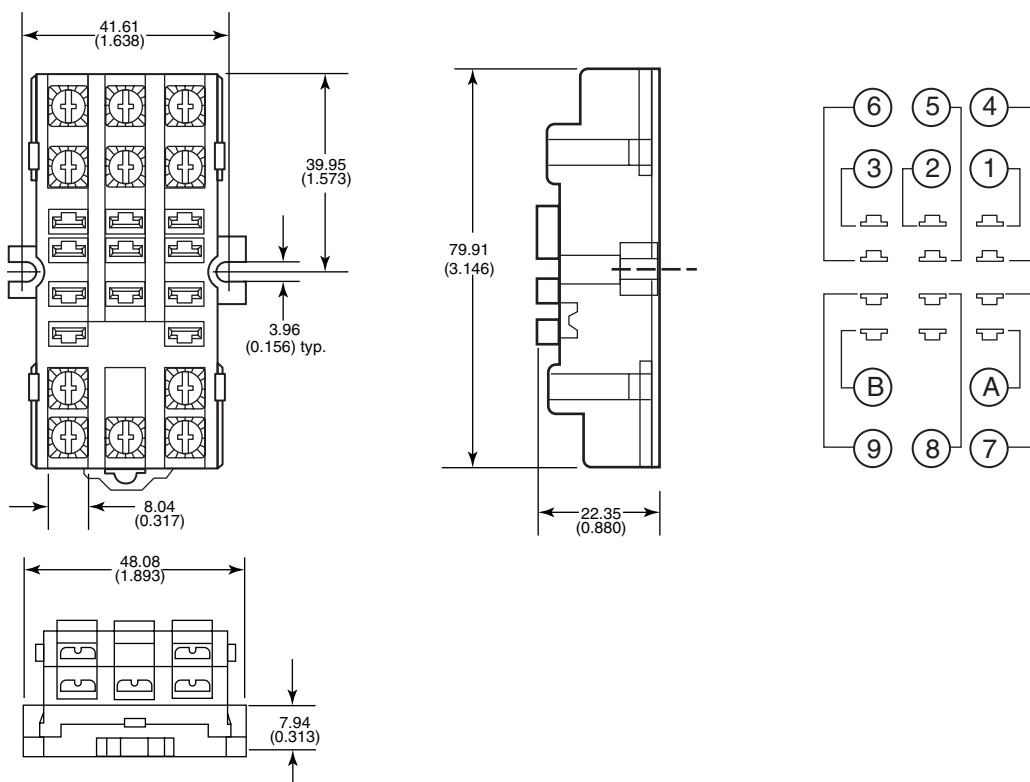

**PTFPCB**

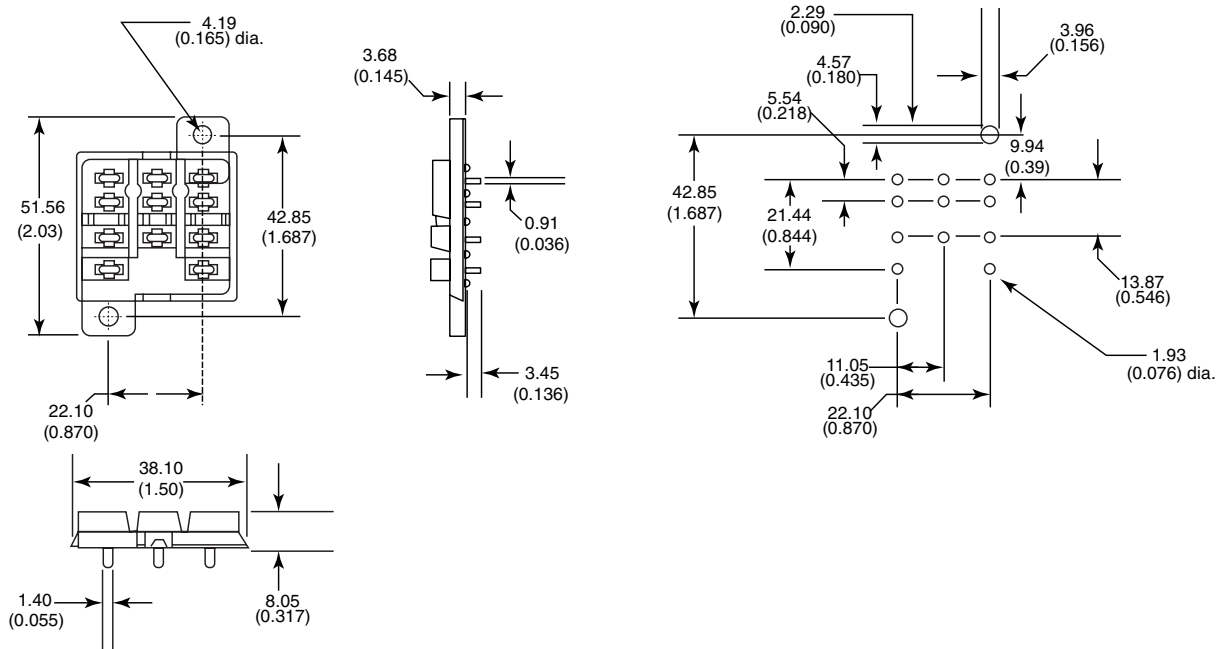

**PTF11QDC**

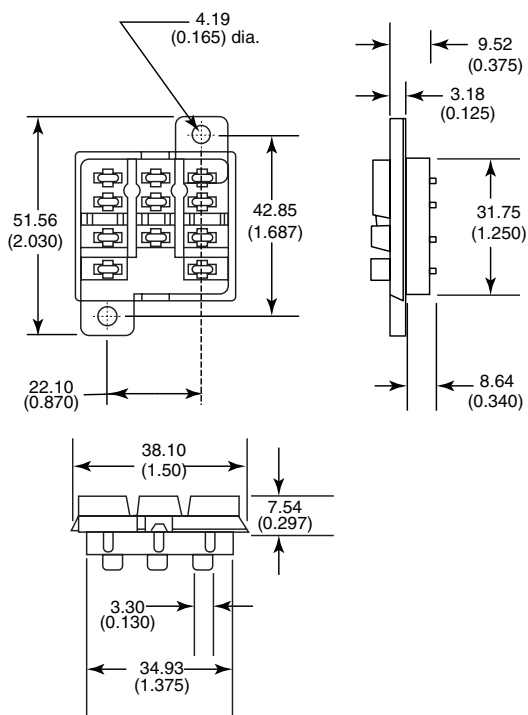

**ALL DIMENSIONS SHOWN ARE IN MILLIMETERS.**  
 To convert millimeters into inches, multiply by 0.03937. To convert grams into ounces, multiply by 0.03527.