

Alkaline-Manganese Dioxide Battery

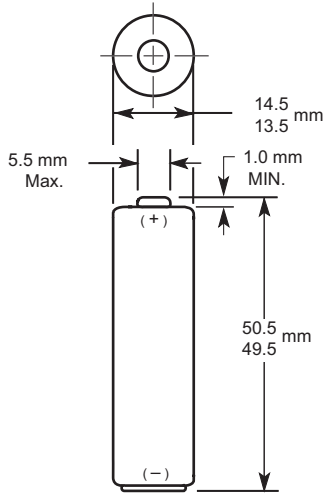

Dimensions shown are ANSI standards

Nominal Voltage:	1.5 V
Operating Voltage	1.6 - 0.75V
Impedance:	81 m-ohm @ 1kHz
Typical Weight:	24 gm (0.8 oz.)
Typical Volume:	8.4 cm ³ (0.5 in. ³)
Terminals:	Flat
Storage Temperature Range:	-20 °C to 35 °C
Operating Temperature Range:	-20 °C to 54 °C (-4 °F to 130 °F)
ANSI:	15A
IEC:	LR6

TYPICAL DISCHARGE CHARACTERISTICS AT VARIOUS POWER DRAINS

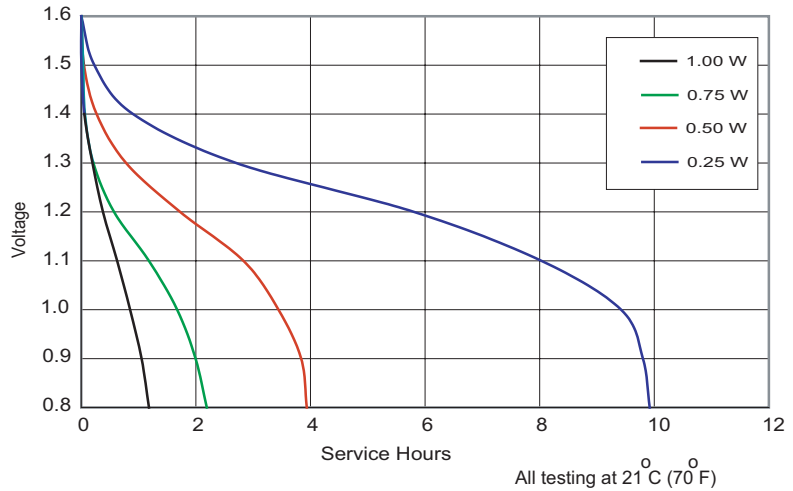

* Delivered capacity is dependent on the applied load, operating temperature and cut-off voltage. Please refer to the charts and discharge data shown for examples of the energy / service life that the battery will provide for various load conditions.

DURACELL®

SPECIFICATION SUMMARY:

SELECTED PRODUCTS

ALKALINE PRIMARY CELLS & BATTERIES

DURACELL® alkaline-manganese dioxide batteries are a popular choice for most consumer, industrial, and military applications where an economical, general purpose battery is required. Advantages include high energy output, reliability, long shelf life, and good low temperature performance.⁽¹⁾ The DURACELL® alkaline battery system is generally available in cylindrical and multicell configurations.

DURACELL PRODUCT NUMBER	SIZE	NOMINAL VOLTAGE (V)	DIMENSIONS ⁽²⁾						NOMINAL WEIGHT		NOMINAL VOLUME		CROSS REFERENCE	
			MAXIMUM		MAXIMUM		MAXIMUM		g	oz.	cm ³	in ³	ANSI	IEC
			mm	in.	mm	in.	mm	in.						

STANDARD CYLINDRICAL CELLS

			DIAMETER		HEIGHT										
			mm	in.	mm	in.									
MN1300	D	1.5	34.2	1.35	61.5	2.42	-	-	139	4.90	56.4	3.44	13A	LR20	
MN1400	C	1.5	26.2	1.03	50	1.97	-	-	69.0	2.43	26.9	1.64	14A	LR14	
MN1500	AA	1.5	14.5	0.57	50.5	1.99	-	-	23.8	0.84	8.4	0.51	15A	LR6	
MN2400	AAA	1.5	10.5	0.41	44.5	1.75	-	-	11.0	0.39	3.8	0.23	24A	LR03	
MN9100	N	1.5	12	0.47	30.2	1.19	-	-	9.6	0.34	3.4	0.21	910A	LR1	

ULTRA CYLINDRICAL CELLS

			DIAMETER		HEIGHT										
			mm	in.	mm	in.									
MX1300	D	1.5	34.2	1.35	61.5	2.42	-	-	147	5.19	56.4	3.44	13A	LR20	
MX1400	C	1.5	26.2	1.03	50.0	1.97	-	-	71.7	2.53	26.9	1.64	14A	LR14	
MX1500	AA	1.5	14.5	0.57	50.5	1.99	-	-	24.4	0.86	8.4	0.51	15A	LR6	
MX2400	AAA	1.5	10.5	0.41	44.5	1.75	-	-	11.2	0.40	3.8	0.23	24A	LR03	
MX2500	AAAA	1.5	8.3	0.33	42.5	1.67	-	-	6.0	0.21	2.3	0.14	25A	LR8D425	

OTHER SELECTED MULTICELL

DURACELL PRODUCT NUMBER	SIZE	NOMINAL VOLTAGE (V)	LENGTH		HEIGHT		WIDTH		g	oz.	cm ³	in ³	ANSI	IEC
			mm	in.	mm	in.	mm	in.						
MX1604	ULTRA 9-VOLT	9	26.5	1.04	48.5	1.91	17.5	0.69	46.5	1.64	22.8	1.39	1604A	6LR61
MN1604	9-VOLT	9	26.5	1.04	48.5	1.91	17.5	0.69	45.0	1.60	22.8	1.39	1604A	6LR61
7K67	J	6	35.6	1.40	48.5	1.91	9.1	0.36	34.0	1.20	15.7	0.96	1412AP	4LR61
MN908	LANTERN	6	67.0	2.64	115	4.53	67.0	2.64	612	21.6	501.8	30.6	908A	4LR25X
MN918	LANTERN	6	136.5	5.37	127	5.00	73.0	2.87	1270	44.8	1243.5	75.9	918A	4LR25-2
MN1203	LANTERN	4.5	62.0	2.44	67.0	2.64	22.0	0.87	154	5.43	91.4	5.58	-	3LR12
MN21	CYLINDRICAL	12	10.3	0.41	28.5	1.12	-	-	7.40	0.26	2.30	0.14	-	-

(1) Operating temperature range is -20°C to 54°C (-4°F to 130°F)

(2) Dimensions are IEC/ANSI standards.