

H MICRO SWITCH
 FREEPORT, ILLINOIS, U S A
 A DIVISION OF HONEYWELL
 FED. MFG. CODE 91929

ACTUATOR-SWITCH

CATALOG LISTING
JX-89

X37131

REPLACES

RELEASE NO. SR-12803

M JX-89

DRAWING NUMBER

ISSUE
 4

REVISIONS

A	C050514	J A P	2 NOV 81
B	C079303	DLT	9 MAR 95
C	C082929	DLT	13 MAY 96

CHECK

3 APR 67

KAC

3 APR 67

CHECK

3 APR 67

CHECK

3 APR 67

CHECK

3 APR 67

CHECK

3 APR 67

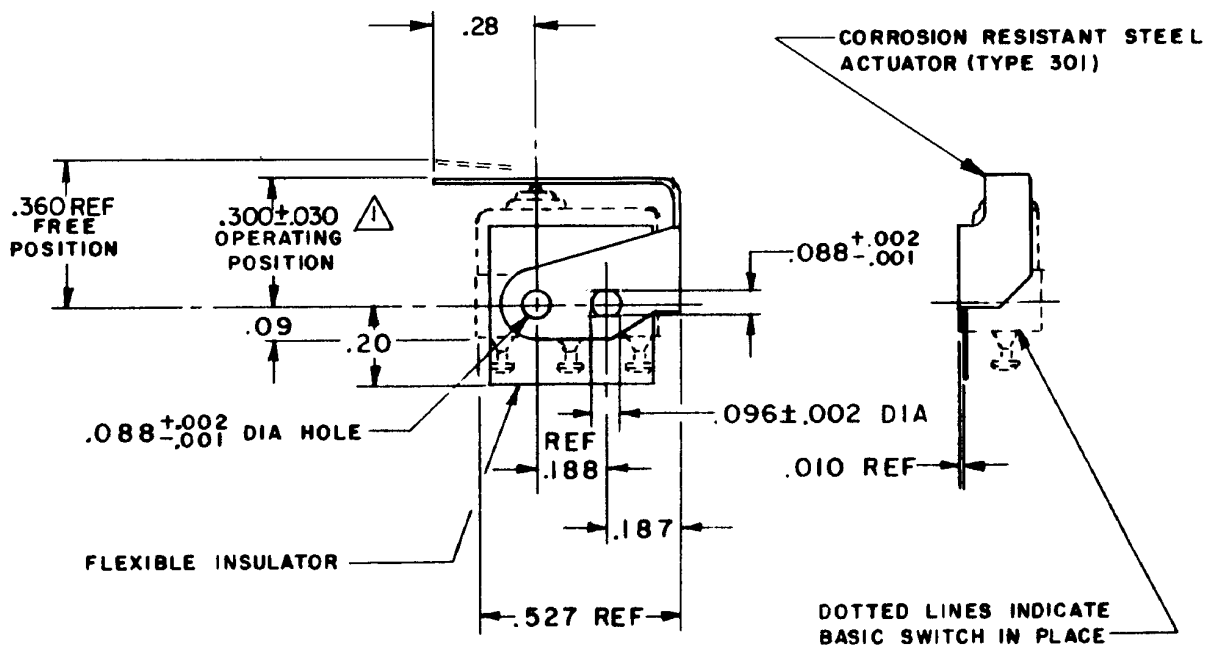
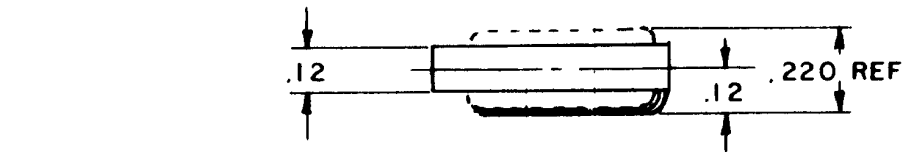

NOTE -
 ▲ SLIGHT ROTATION BETWEEN BASIC AND ACTUATOR MAY BE NECESSARY TO OBTAIN OPERATING POINT BASED ON MOUNTING WITH NO. 2-56 UNC MACHINE SCREWS

THIS DRAWING COVERS A PROPRIETARY ITEM AND IS THE PROPERTY OF MICRO SWITCH, A DIVISION OF HONEYWELL THIS DRAWING IS NOT TO BE COPIED OR USED WITHOUT THE APPROVAL OF MICRO SWITCH.

CHARACTERISTICS WITH ISX1-T BASIC SWITCH INSTALLED
OPERATING FORCE----- 7 OZ MAX
RELEASE FORCE----- 2 OZ MIN
DIFFERENTIAL TRAVEL----- .025 MAX
OVERTRAVEL----- .015 MIN

ELECTRICAL DATA

CONTACT ARRANGEMENT

SCALE 2 TO 1
DO NOT SCALE PRINT
UNLESS OTHERWISE NOTED
DIMENSIONS ARE IN INCHES
TOLERANCES ARE:
ONE PLACE (.0) ± .030
TWO PLACE (.00) ± .015
THREE PLACE (.000) ± .005
ANGLES ±
WEIGHT

FO-50378

DRAWN

RER 31 MAR 67