

Products & Applications: Soldering/Desoldering

>> Home > Products & Applications > Soldering/Desoldering > STTC Tip Cartridges for MX Systems

MX-500

Most popular standard recommended tip cartridges

These cartridges are Metcal's most popular. Owning these tips will help you to complete almost every soldering task

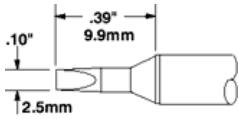
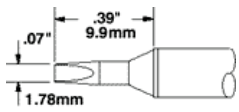
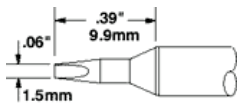
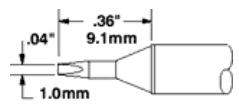

	<p>STTC-X36*</p> <p>Chisel 30° .10 (2.5mm)</p>
	<p>STTC-X37*</p> <p>Chisel 30° .07 (1.78mm)</p>
<p>For a wide variety of tasks. If you are choosing the first tip for your Metcal system, the STTC-037 is ideal.</p>	
	<p>STTC-X38*</p> <p>Chisel 30° .06 (1.5mm)</p>
<p>A finer version of the STTC-037. Ideal for medium to light through-hole and general surface mount touch-up.</p>	
	<p>STTC-X25</p> <p>Chisel 30° .04 (1.0mm)</p>

Good for a variety of light soldering tasks. Looking for a surface mount touch-up tip? The STTC-025 should be your first choice.

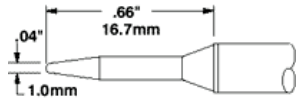

STTC-X07
Conical Sharp .04 (1.0mm)

General-purpose SMT and through-hole tip when access is limited.

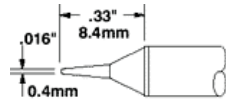

STTC-X22
Conical Sharp .016 (0.4mm)

Sharp tip cartridges for soldering SMT components or fine wire applications (not for general through-hole tasks).

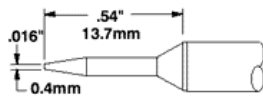

STTC-X06
Conical Sharp .016 (0.4mm)

For limited access SMT rework.

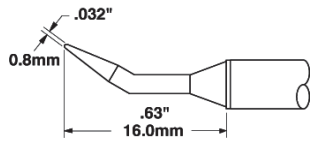

STTC-X40
Sharp Bent 30° .032
(0.8mm)

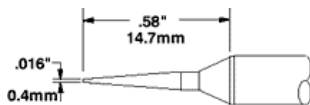

Tip for soldering SMT components. The bend makes it much easier to work on small circuits and PLCCs.



STTC-X45
Bevel 60° .016 (0.4mm)

An extended length fine tip for surface mount or fine wire applications (not for general through-hole tasks).

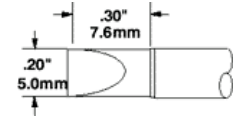
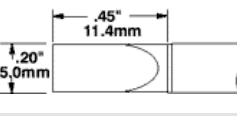
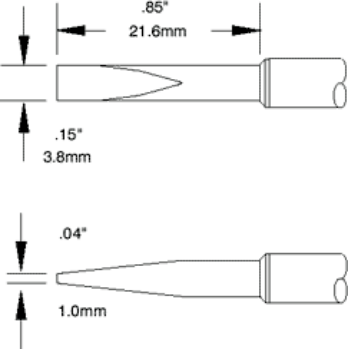
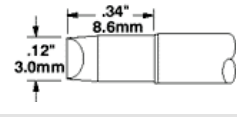
500 series x=5, 600 series x=0, 700 series x=1, 800 series x=8, when followed by an *

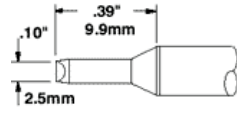
Other Standard Cartridges	
	<p>STTC-X17* Extra Large Chisel .20 (5.0mm)</p>
	<p>STTC-X65 Large Chisel .20 (5.0mm)</p>
	<p>STTC-X20 Long Reach Chisel 12° .15 (3.8mm)</p>
	<p>STTC-X03* Chisel 90° .12 (3.0mm)</p>
	<p>STTC-X13 Chisel 90° .12 (3.0mm)</p>
	<p>STTC-X33 Chisel 90° .10 (2.5mm)</p>

	<p>STTC-X04 Chisel 90° .07 (1.78mm)</p>
	<p>STTC-X42 Long Reach Chisel 60° .07 (1.78mm)</p>
	<p>STTC-X98 Chisel Bent 30° .07 (1.78mm)</p>
	<p>STTC-X99 Chisel Bent 30° .06 (1.5mm)</p>
	<p>STTC-X41 Chisel 30° .05 (1.3mm)</p>
	<p>STTC-X83 Conical Grooved .08 (2.0mm)</p>
	<p>STTC-X32 Conical Sharp .07 (1.78mm)</p>

	<p>STTC-X02 Conical Sharp .07 (1.78mm)</p>
	<p>STTC-X01 Conical Sharp .04 (1.0mm)</p>
	<p>STTC-X31 Conical Sharp .04 (1.0mm)</p>
	<p>STTC-X43 Conical Sharp .02 (0.5mm)</p>
	<p>STTC-X12 Conical .08 (2.03mm)</p>
	<p>STTC-X11 Conical .02 (0.5mm)</p>
	<p>STTC-X16 Conical .02 (0.5mm)</p>
	<p>STTC-X44 Sharp Bent 30° .02 (0.5mm)</p>
	<p>STTC-X26 Sharp Bent 30° .016 (0.4mm)</p>

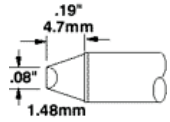
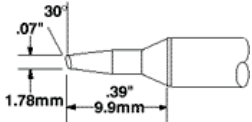
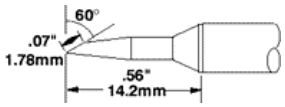
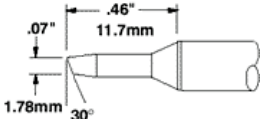
	<p>STTC-X14</p> <p>Bevel 45°</p> <p>.08 (2.03mm)</p>
	<p>STTC-X35</p> <p>Bevel 30°</p> <p>.07 (1.78mm)</p>
	<p>STTC-X47</p> <p>Bevel 60°</p> <p>.07 (1.78mm)</p>
	<p>STTC-X05</p> <p>Bevel 30°</p> <p>.07 (1.78mm)</p>

Specialty cartridges

Specialty cartridges are more expensive than Metcal's standard cartridges. If you think that you need a specialty cartridge, you may want to try a standard cartridge first.

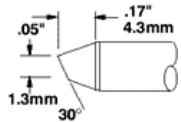
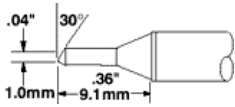
Specialty cartridges Models	
	<p>STTC-X15</p> <p>Bevel 30°</p> <p>.05 (1.3mm)</p>
	<p>STTC-X24</p> <p>Bevel 30°</p> <p>.04 (1.0mm)</p>

	<p>STTC-X97 Grooved Semi-Rigid Coax</p> <p>STTC-X46 Long Reach Bevel 60° .04 (1.0mm)</p>
	<p>STTC-X70 Heat Staking .19 (4.8mm)</p>

500 series x=5, 600 series x=0, 700 series x=1, 800 series x=8, when followed by an *



© 2007 OK International. All rights reserved.