

OD1232 Series

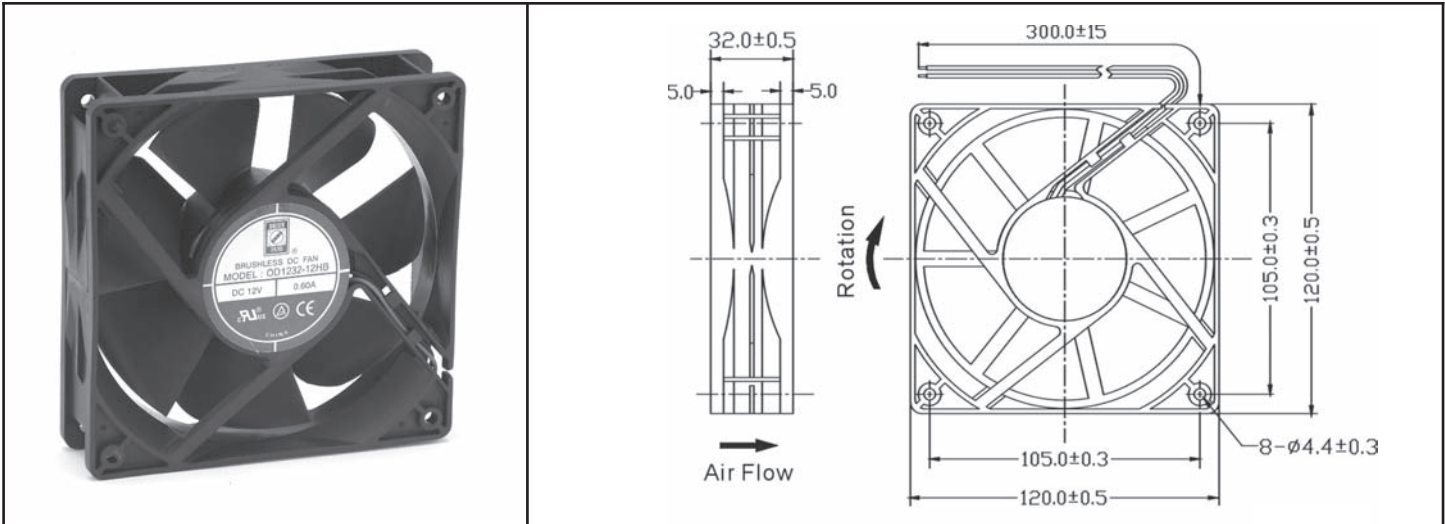

DC Fan - 12, 24, 48V
120x32mm (4.7"x 1.25")



Frame & Impeller	PBT, UL94V-O plastic	Available Options: Tachometer (FG) Alarm (RD) Thermal Speed Control (Thermistor) PWM Input (Manual Speed Control) Life Expectancy (L10) Ball Bearing 60,000 hours (L10 at 40C) Sleeve Bearing 30,000 hours (L10 at 40C) Operating Temperature Ball Bearing -20C ~ +80C Sleeve Bearing -10C ~ +50C	
Connection	2x Lead wires		
Motor	Brushless DC, auto restart, impedance and polarity protected		
Bearing System	Dual Ball or Sleeve		
Insulation Resistance	10M ohm between leadwire and frame (500VDC)		
Dielectric Strength	1 second at 500 VAC, max leakage - 500 MicroAmp		
Storage Temperature	-30C ~ +90C		

Model Number	Speed (RPM)	Airflow (CFM)	Noise (dB)	Volts DC	Voltage Range	Amps	Max. Static Pressure ("H2O)
OD1232-12H *	3750	120	51	12	6~13.8	0.60	0.42
OD1232-12M *	3300	107	48	12	6~13.8	0.50	0.33
OD1232-12L *	2900	93	44	12	6~13.8	0.32	0.27
OD1232-24H *	3750	120	51	24	12~27.8	0.45	0.42
OD1232-24M *	3300	107	48	24	12~27.8	0.28	0.33
OD1232-24L *	2900	93	44	24	12~27.8	0.22	0.27
OD1232-48H *	3750	120	51	48	24~55.2	0.18	0.42
OD1232-48M *	3300	107	48	48	24~55.2	0.15	0.33
OD1232-48L *	2900	93	44	48	24~55.2	0.13	0.27

* Indicate "B" to specify Ball bearing or "S" to specify Sleeve bearing