

ENM Counting Instruments > Electrical Counters > E6B Electrical Counter - Two-Hole Panel Mount > T14 DC Powered Hour Meter II. > T14 DC Powered Hour Meter I. > T18 AC Powered Hour Meter III. > T18 AC Powered Hour Meter II. > T32 AC/DC DIN Rail Mount Hour Meter > T40 Quartz DC Hour Meter > T40 3-Hole Quartz DC Hour Meter > T40 Square Mount Quartz DC Hour Meter II. > T41 Quartz DC Hour Meter II. > T41 Quartz DC Hour Meter I. > T50 Quartz AC Hour Meter I. > T50 Quartz AC Hour Meter II. > Item # T50B212

Item # T50B212 with NEMA 4x12 Gasket

with NEMA 4x12 Gasket

ENM's series T50 AC hour meter in a large 3-hole flange. Includes NEMA 4X. 12 rated panel gasket for water and corrosion resistant panel mounting (see accessories). A quartz crystal time base insures accurate time keeping. This model is also frequency insensitive.



Specifications

Series	T50
Display	6-Digit
Voltage	115 V AC
Reset	None
Size	1.68W x 1.68H x 1.26D Inch
Face Dia - Flange	2.8 Inch
Face Dia - Cutout	2 Inch
Weight	2 oz.
Mounting Style	3-Hole Panel
Power	Less than 0.4 W

Item # T50B212, with NEMA 4x12 Gasket

Dimensional Drawing

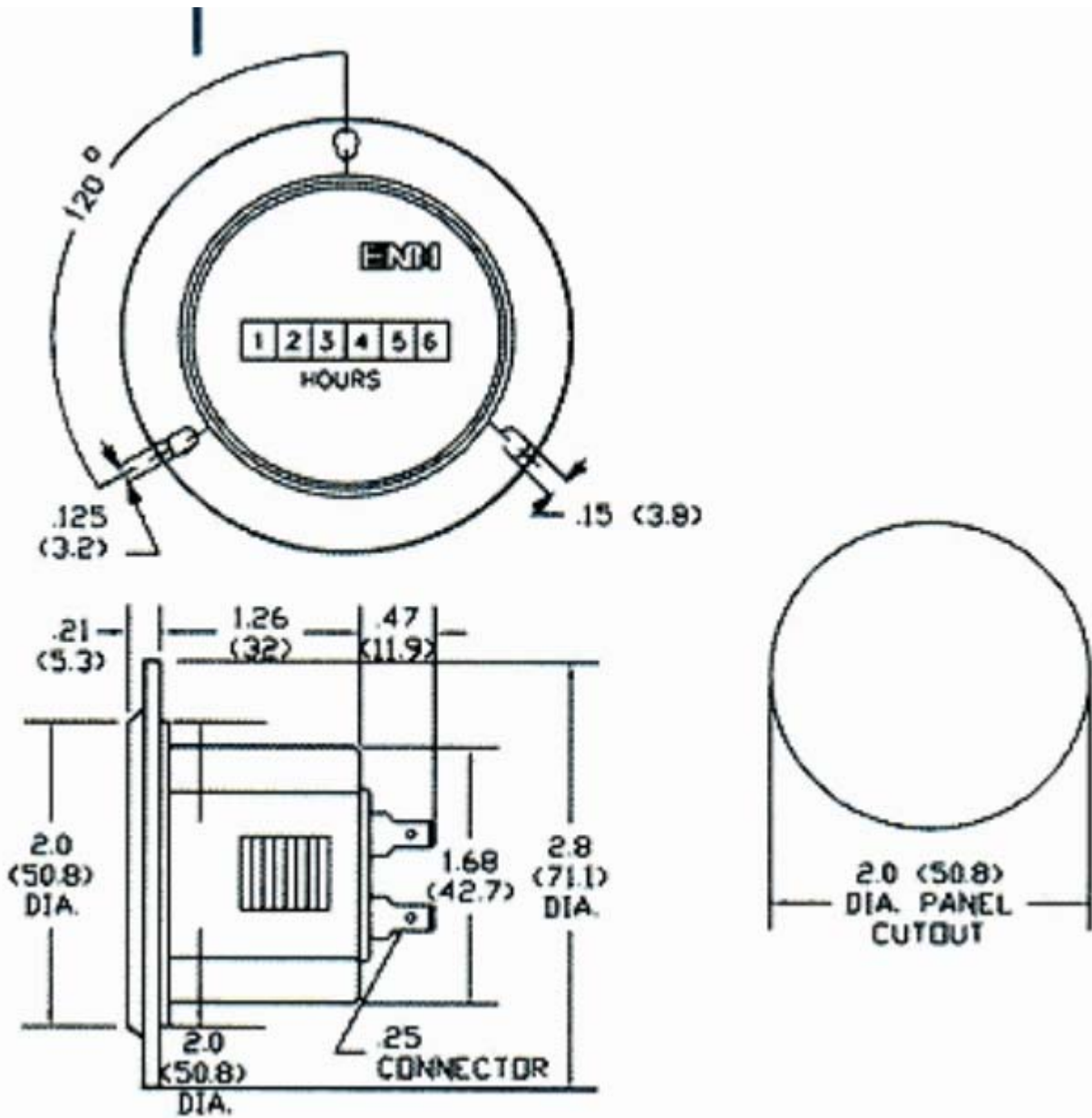

PANEL

Panel Mounting is obtained by cutting a circular or rectangular cut-out in the desired panel and the instrument is inserted with the flange resting on the top of the panel. The instrument is held in place by compressing a plastic or steel spring clip from behind the panel. This type of mounting is very popular because it requires no additional fasteners. Models are also considered panel mounted when they are inserted into a panel cut-out and mounted from the front using a two or more hole flange and fastened with screws from the front of the panel (pictured to the right).



BACK OF PANEL

Back of panel mounting is usually achieved by cutting an opening in a thin panel large enough to read the display. Two or more holes are drilled in the panel and screws are inserted from the front to secure the instrument against the back of the panel wall.



BASE

Base mounting is usually a free standing mount and connections are made with a two or more hole flange at the bottom of the unit. This is a standard mount for most mechanical counters and is sometimes used for hour meters when a panel is not available.

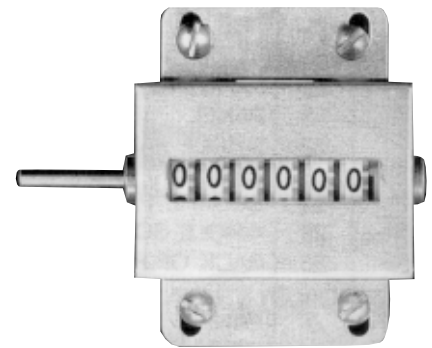

PCB

PC board mounting is common for using counters in add-on PCB modules to electronic machinery. This type of mounting eliminates the need for any wires and multiple counters can be assembled as one unit. The counters are attached by soldering the protruding pins into the PCB and two or more fasteners are also screwed into the bottom of the unit for additional support onto the PC board.

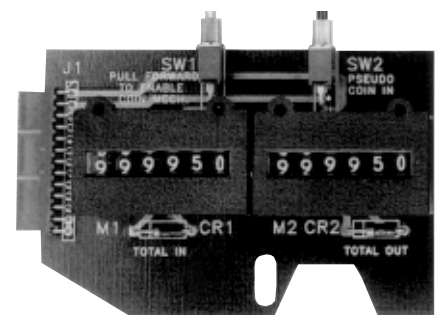

REAR

Rear mounting is similar to PCB mounting except there are no pins for soldering, only two or more holes on the bottom for threaded or self-tapping screws. This is an optional type of mounting used mainly when a suitable panel is not available.

