

2 A positive voltage regulators

Features

- Output current to 2 A
- Output voltages of 5; 7.5; 9; 10; 12; 15; 18; 24 V
- Thermal overload protection
- Short circuit protection
- Output transition SOA protection

Description

The L78Sxx series of three-terminal positive regulators is available in TO-220 and TO-3 packages and several fixed output voltages, making it useful in a wide range of applications. These regulators can provide local on-card regulation, eliminating the distribution problems associated with single point regulation. Each type employs internal current limiting, thermal shut-down and safe area protection, making it essentially indestructible. If adequate heat sinking is provided, they can deliver over 2 A output current. Although designed primarily as fixed voltage regulators, these devices can be used with external components to obtain adjustable voltages and currents.

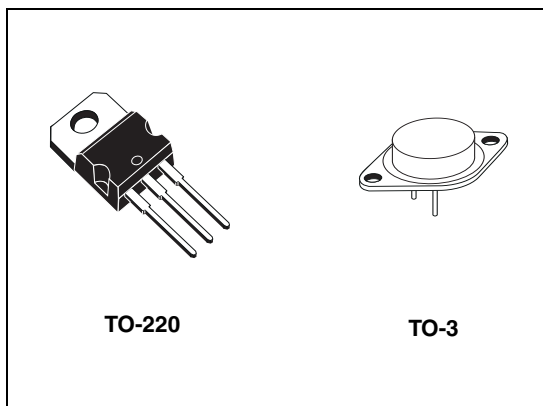

Table 1. Device summary

Part numbers			
L78S05	L78S09	L78S12	L78S18
L78S05C	L78S09C	L78S12C	L78S18C
L78S75	L78S10	L78S15	L78S24
L78S75C	L78S10C	L78S15C	L78S24C

Contents

1	Diagram	5
2	Pin configuration	6
3	Maximum ratings	7
4	Test circuits	8
5	Electrical characteristics	9
6	Typical performance	22
7	Package mechanical data	32
8	Order codes	37
9	Revision history	38

List of tables

Table 1.	Device summary	1
Table 2.	Absolute maximum ratings	7
Table 3.	Thermal data.	7
Table 4.	Electrical characteristics of L78S05	9
Table 5.	Electrical characteristics of L78S75	10
Table 6.	Electrical characteristics of L78S09	10
Table 7.	Electrical characteristics of L78S10	11
Table 8.	Electrical characteristics of L78S12	11
Table 9.	Electrical characteristics of L78S15	12
Table 10.	Electrical characteristics of L78S18	12
Table 11.	Electrical characteristics of L78S24	13
Table 12.	Electrical characteristics of L78S05C	14
Table 13.	Electrical characteristics of L78S75C	15
Table 14.	Electrical characteristics of L78S09C	16
Table 15.	Electrical characteristics of L78S10C	17
Table 16.	Electrical characteristics of L78S12C	18
Table 17.	Electrical characteristics of L78S15C	19
Table 18.	Electrical characteristics of L78S18C	20
Table 19.	Electrical characteristics of L78S24C	21
Table 20.	TO-220 mechanical data	32
Table 21.	Order codes	37
Table 22.	Document revision history	38

List of figures

Figure 1.	Block diagram	5
Figure 2.	Pin connections (top view)	6
Figure 3.	Schematic diagram	6
Figure 4.	Application circuits	7
Figure 5.	DC parameter	8
Figure 6.	Load regulation	8
Figure 7.	Ripple rejection	8
Figure 8.	Dropout voltage vs. junction temperature	22
Figure 9.	Peak output current vs. input/output differential voltage	22
Figure 10.	Output impedance vs. frequency	22
Figure 11.	Output voltage vs. junction temperature	22
Figure 12.	Supply voltage rejection vs. frequency	22
Figure 13.	Quiescent current vs. junction temperature	22
Figure 14.	Load transient response	23
Figure 15.	Line transient response	23
Figure 16.	Quiescent current vs. input voltage	23
Figure 17.	Fixed output regulator	23
Figure 18.	Constant current regulator	24
Figure 19.	Circuit for increasing output voltage	24
Figure 20.	Adjustable output regulator (7 to 30 V)	24
Figure 21.	0.5 to 10 V regulator	25
Figure 22.	High current voltage regulator	25
Figure 23.	High output current with short circuit protection	25
Figure 24.	Tracking voltage regulator	26
Figure 25.	Positive and negative regulator	26
Figure 26.	Negative output voltage circuit	27
Figure 27.	Switching regulator	27
Figure 28.	High input voltage circuit	27
Figure 29.	High input voltage circuit	28
Figure 30.	High output voltage regulator	28
Figure 31.	High input and output voltage	28
Figure 32.	Reducing power dissipation with dropping resistor	29
Figure 33.	Remote shutdown	29
Figure 34.	Power AM modulator (unity voltage gain, $I_O \leq 1$ A)	29
Figure 35.	Adjustable output voltage with temperature compensation	30
Figure 36.	Light controllers ($V_{Omin} = V_{XX} + V_{BE}$)	30
Figure 37.	Protection against input short-circuit with high capacitance loads	31
Figure 38.	Drawing dimension TO-220 (type STD-ST Dual Gauge)	33
Figure 39.	Drawing dimension TO-220 (type STD-ST Single Gauge)	34
Figure 40.	Drawing dimension tube for TO-220 Dual Gauge (mm.)	35
Figure 41.	Drawing dimension tube for TO-220 Single Gauge (mm.)	35

1 Diagram

Figure 1. Block diagram

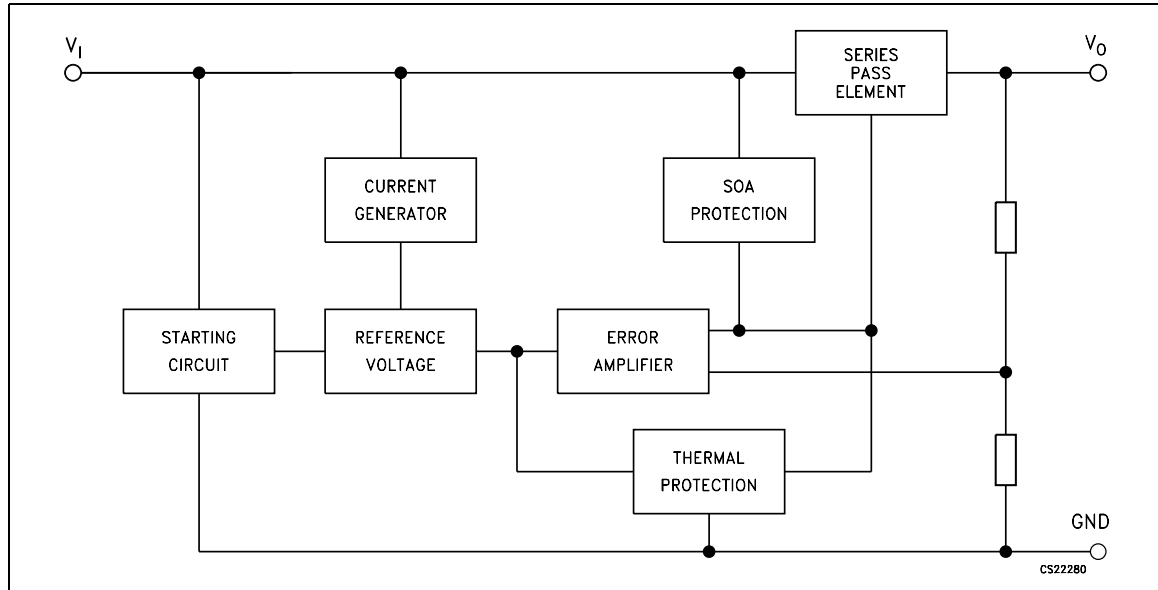

2 Pin configuration

Figure 2. Pin connections (top view)

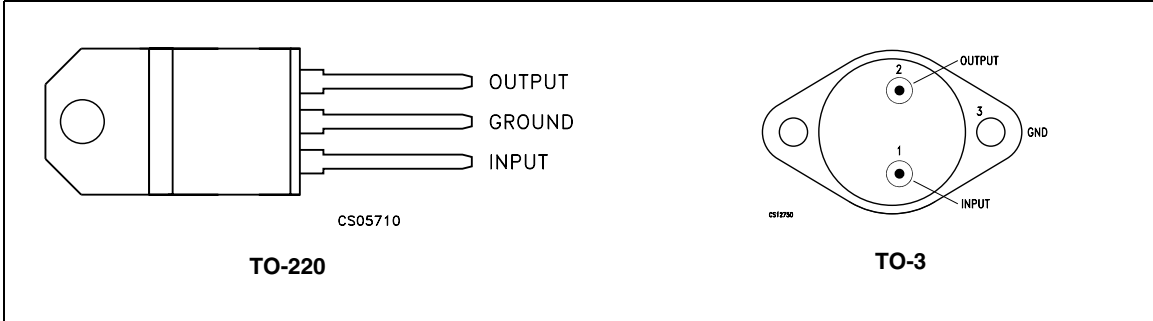
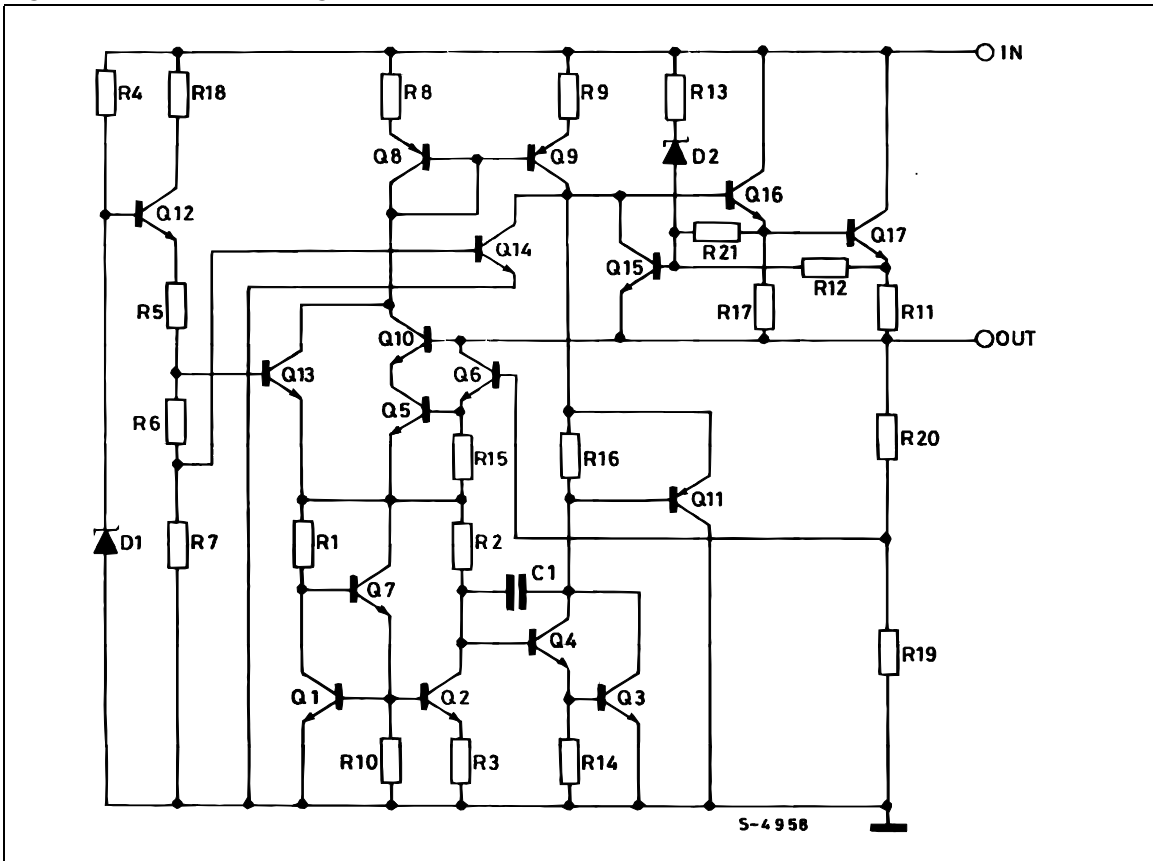

Figure 3. Schematic diagram



3 Maximum ratings

Table 2. Absolute maximum ratings

Symbol	Parameter	Value	Unit
V_I	DC input voltage	for $V_O = 5$ to 18V	35
		for $V_O = 24$ V	40
I_O	Output current	Internally limited	
P_D	Power dissipation	Internally limited	
T_{STG}	Storage temperature range	-65 to 150	°C
T_{OP}	Operating junction temperature range	for L78Sxx	-55 to 150
		for L78SxxC	0 to 150

Note: Absolute maximum ratings are those values beyond which damage to the device may occur. Functional operation under these condition is not implied.

Table 3. Thermal data

Symbol	Parameter	TO-220	TO-3	Unit
R_{thJC}	Thermal resistance junction-case	5	4	°C/W
R_{thJA}	Thermal resistance junction-ambient	50	35	°C/W

Figure 4. Application circuits

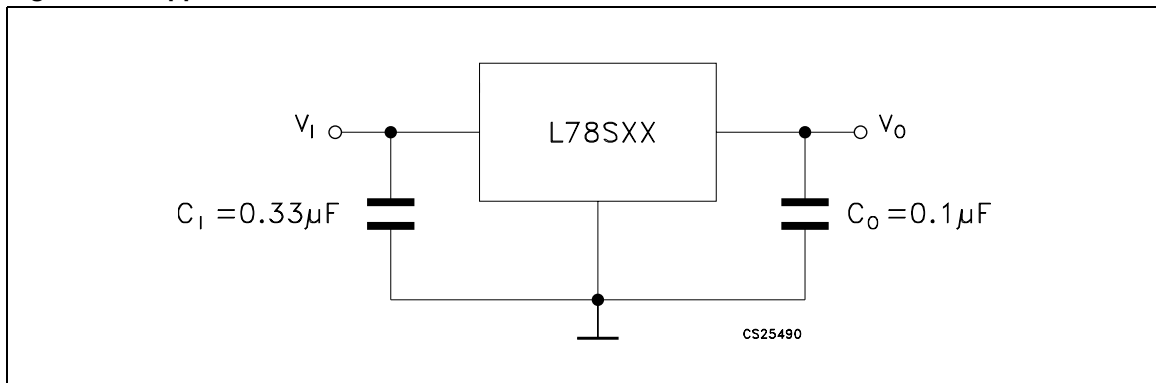

4 Test circuits

Figure 5. DC parameter

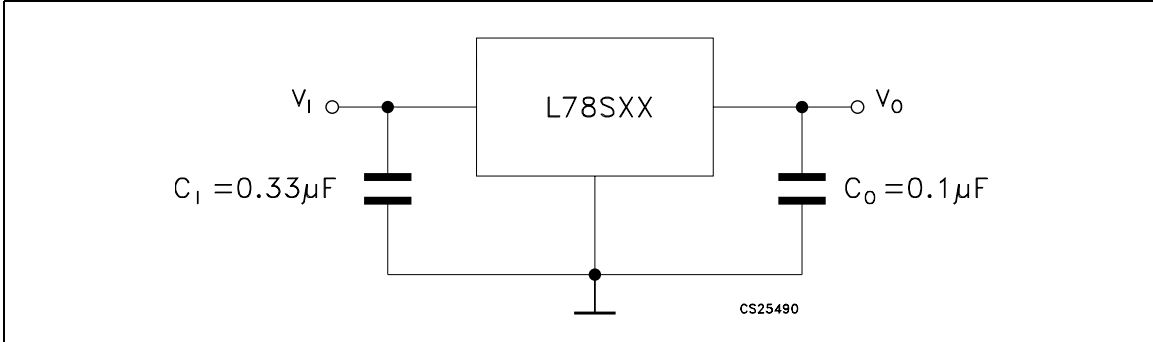

Figure 6. Load regulation

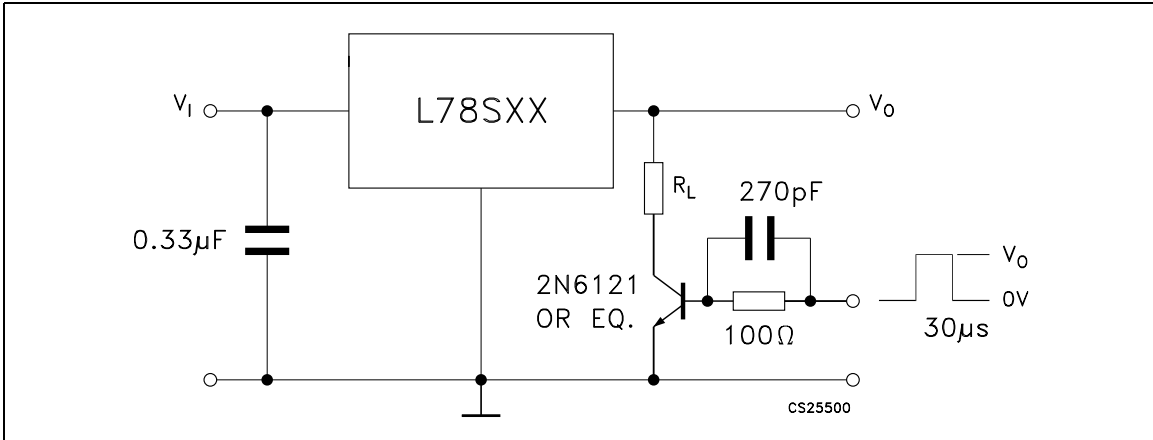
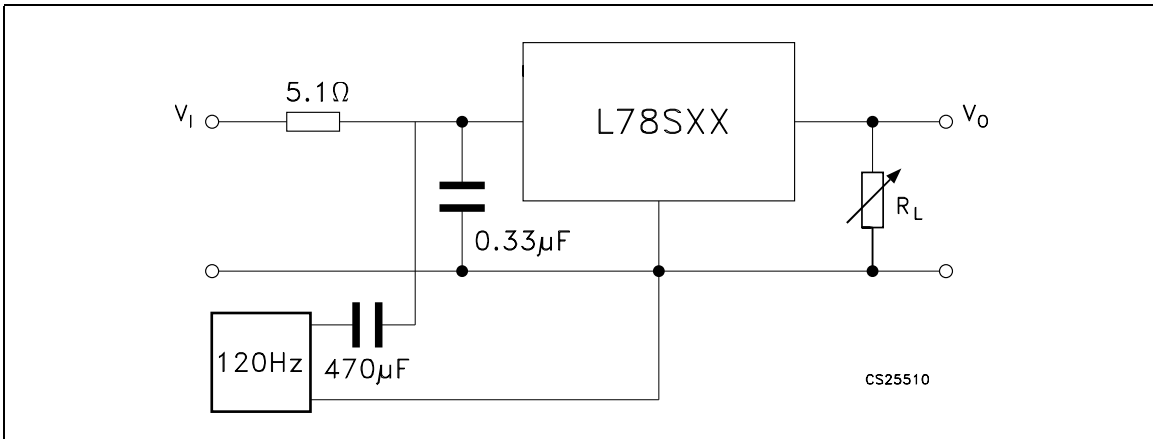

Figure 7. Ripple rejection



5 Electrical characteristics

Refer to the test circuits, $T_J = 25\text{ °C}$, $V_I = 10\text{ V}$, $I_O = 500\text{ mA}$, unless otherwise specified.

Table 4. Electrical characteristics of L78S05

Symbol	Parameter	Test conditions	Min.	Typ.	Max.	Unit
V_O	Output voltage		4.8	5	5.2	V
V_O	Output voltage	$I_O = 1\text{ A}$, $V_I = 7\text{ V}$	4.75	5	5.25	V
ΔV_O	Line regulation	$V_I = 7\text{ to }25\text{ V}$			100	mV
		$V_I = 8\text{ to }25\text{ V}$			50	
ΔV_O	Load regulation	$I_O = 20\text{ mA to }2\text{ A}$			100	mV
I_Q	Quiescent current				8	mA
ΔI_Q	Quiescent current change	$I_O = 20\text{ mA to }1\text{ A}$			0.5	mA
		$V_I = 7\text{ to }25\text{ V}$, $I_O = 20\text{ mA}$			1.3	
$\Delta V_O/\Delta T$	Output voltage drift	$I_O = 5\text{ mA}$, $T_J = -55\text{ °C to }150\text{ °C}$		-1.1		mV/°C
eN	Output noise voltage	$B = 10\text{ Hz to }100\text{ kHz}$		40		μV
SVR	Supply voltage rejection	$f = 120\text{ Hz}$	60			dB
V_I	Operating input voltage	$I_O \leq 1\text{ A}$	8			V
R_O	Output resistance	$f = 1\text{ kHz}$		17		m Ω
I_{sc}	Short circuit current	$V_I = 27\text{ V}$		500		mA
I_{scp}	Short circuit peak current			3		A

Refer to the test circuits, $T_J = 25\text{ °C}$, $V_I = 12.5\text{ V}$, $I_O = 500\text{ mA}$, unless otherwise specified.

Table 5. Electrical characteristics of L78S75

Symbol	Parameter	Test conditions	Min.	Typ.	Max.	Unit
V_O	Output voltage		7.15	7.5	7.9	V
V_O	Output voltage	$I_O = 1\text{ A}$, $V_I = 9.5\text{ V}$	7.1	7.5	7.95	V
ΔV_O	Line regulation	$V_I = 9.5\text{ to }25\text{ V}$			120	mV
		$V_I = 10.5\text{ to }20\text{ V}$			60	
ΔV_O	Load regulation	$I_O = 20\text{ mA to }2\text{ A}$			120	mV
I_Q	Quiescent current				8	mA
ΔI_Q	Quiescent current change	$I_O = 20\text{ mA to }1\text{ A}$			0.5	mA
		$I_O = 20\text{ mA}$, $V_I = 9.5\text{ to }25\text{ V}$			1.3	
$\Delta V_O/\Delta T$	Output voltage drift	$I_O = 5\text{ mA}$, $T_J = -55\text{ °C to }150\text{ °C}$		-0.8		mV/°C
eN	Output noise voltage	$B = 10\text{ Hz to }100\text{ kHz}$		52		μV
SVR	Supply voltage rejection	$f = 120\text{ Hz}$	54			dB
V_I	Operating input voltage	$I_O \leq 1.5\text{ A}$	10.5			V
R_O	Output resistance	$f = 1\text{ kHz}$		16		m Ω
I_{sc}	Short circuit current	$V_I = 27\text{ V}$		500		mA
I_{scp}	Short circuit peak current			3		A

Refer to the test circuits, $T_J = 25\text{ °C}$, $V_I = 14\text{ V}$, $I_O = 500\text{ mA}$, unless otherwise specified.

Table 6. Electrical characteristics of L78S09

Symbol	Parameter	Test conditions	Min.	Typ.	Max.	Unit
V_O	Output voltage		8.65	9	9.35	V
V_O	Output voltage	$I_O = 1\text{ A}$, $V_I = 11\text{ V}$	8.6	9	9.4	V
ΔV_O	Line regulation	$V_I = 11\text{ to }25\text{ V}$			130	mV
		$V_I = 11\text{ to }20\text{ V}$			65	
ΔV_O	Load regulation	$I_O = 20\text{ mA to }2\text{ A}$			130	mV
I_Q	Quiescent current				8	mA
ΔI_Q	Quiescent current change	$I_O = 20\text{ mA to }1\text{ A}$			0.5	mA
		$V_I = 11\text{ to }25\text{ V}$, $I_O = 20\text{ mA}$			1.3	
$\Delta V_O/\Delta T$	Output voltage drift	$I_O = 5\text{ mA}$, $T_J = -55\text{ °C to }150\text{ °C}$		-1		mV/°C
eN	Output noise voltage	$B = 10\text{ Hz to }100\text{ kHz}$		60		μV
SVR	Supply voltage rejection	$f = 120\text{ Hz}$	53			dB
V_I	Operating input voltage	$I_O \leq 1.5\text{ A}$	12			V
R_O	Output resistance	$f = 1\text{ kHz}$		17		m Ω
I_{sc}	Short circuit current	$V_I = 27\text{ V}$		500		mA
I_{scp}	Short circuit peak current			3		A

Refer to the test circuits, $T_J = 25\text{ °C}$, $V_I = 15\text{ V}$, $I_O = 500\text{ mA}$, unless otherwise specified.

Table 7. Electrical characteristics of L78S10

Symbol	Parameter	Test conditions	Min.	Typ.	Max.	Unit
V_O	Output voltage		9.5	10	10.5	V
V_O	Output voltage	$I_O = 1\text{ A}$, $V_I = 12.5\text{ V}$	9.4	10	10.6	V
ΔV_O	Line regulation	$V_I = 12.5\text{ to }30\text{ V}$			200	mV
		$V_I = 14\text{ to }22\text{ V}$			100	
ΔV_O	Load regulation	$I_O = 20\text{ mA to }2\text{ A}$			150	mV
I_Q	Quiescent current				8	mA
ΔI_Q	Quiescent current change	$I_O = 20\text{ mA to }1\text{ A}$			0.5	mA
		$V_I = 12.5\text{ to }30\text{ V}$, $I_O = 20\text{ mA}$			1	
$\Delta V_O/\Delta T$	Output voltage drift	$I_O = 5\text{ mA}$, $T_J = -55\text{ °C to }150\text{ °C}$		-1		mV/°C
eN	Output noise voltage	$B = 10\text{ Hz to }100\text{ kHz}$		65		μV
SVR	Supply voltage rejection	$f = 120\text{ Hz}$	53			dB
V_I	Operating input voltage	$I_O \leq 1.5\text{ A}$	13			V
R_O	Output resistance	$f = 1\text{ kHz}$		17		m Ω
I_{sc}	Short circuit current	$V_I = 27\text{ V}$		500		mA
I_{scp}	Short circuit peak current			3		A

Refer to the test circuits, $T_J = 25\text{ °C}$, $V_I = 19\text{ V}$, $I_O = 500\text{ mA}$, unless otherwise specified.

Table 8. Electrical characteristics of L78S12

Symbol	Parameter	Test conditions	Min.	Typ.	Max.	Unit
V_O	Output voltage		11.5	12	12.5	V
V_O	Output voltage	$I_O = 1\text{ A}$, $V_I = 14.5\text{ V}$	11.4	12	12.6	V
ΔV_O	Line regulation	$V_I = 14.5\text{ to }30\text{ V}$			240	mV
		$V_I = 16\text{ to }22\text{ V}$			120	
ΔV_O	Load regulation	$I_O = 20\text{ mA to }2\text{ A}$			160	mV
I_Q	Quiescent current				8	mA
ΔI_Q	Quiescent current change	$I_O = 20\text{ mA to }1\text{ A}$			0.5	mA
		$V_I = 14.5\text{ to }30\text{ V}$, $I_O = 20\text{ mA}$			1	
$\Delta V_O/\Delta T$	Output voltage drift	$I_O = 5\text{ mA}$, $T_J = -55\text{ °C to }150\text{ °C}$		-1		mV/°C
eN	Output noise voltage	$B = 10\text{ Hz to }100\text{ kHz}$		75		μV
SVR	Supply voltage rejection	$f = 120\text{ Hz}$	53			dB
V_I	Operating input voltage	$I_O \leq 1.5\text{ A}$	15			V
R_O	Output resistance	$f = 1\text{ kHz}$		18		m Ω
I_{sc}	Short circuit current	$V_I = 27\text{ V}$		500		mA
I_{scp}	Short circuit peak current			3		A

Refer to the test circuits, $T_J = 25\text{ °C}$, $V_I = 23\text{ V}$, $I_O = 500\text{ mA}$, unless otherwise specified.

Table 9. Electrical characteristics of L78S15

Symbol	Parameter	Test conditions	Min.	Typ.	Max.	Unit
V_O	Output voltage		14.4	15	15.6	V
V_O	Output voltage	$I_O = 1\text{ A}$, $V_I = 17.5\text{ V}$	14.25	15	15.75	V
ΔV_O	Line regulation	$V_I = 17.5\text{ to }30\text{ V}$			300	mV
		$V_I = 20\text{ to }26\text{ V}$			150	
ΔV_O	Load regulation	$I_O = 20\text{ mA to }2\text{ A}$			180	mV
I_Q	Quiescent current				8	mA
ΔI_Q	Quiescent current change	$I_O = 20\text{ mA to }1\text{ A}$			0.5	mA
		$V_I = 17.5\text{ to }30\text{ V}$, $I_O = 20\text{ mA}$			1	
$\Delta V_O/\Delta T$	Output voltage drift	$I_O = 5\text{ mA}$, $T_J = -55\text{ °C to }150\text{ °C}$		-1		mV/°C
eN	Output noise voltage	$B = 10\text{ Hz to }100\text{ kHz}$		90		μV
SVR	Supply voltage rejection	$f = 120\text{ Hz}$	52			dB
V_I	Operating input voltage	$I_O \leq 1.5\text{ A}$	18			V
R_O	Output resistance	$f = 1\text{ kHz}$		19		m Ω
I_{sc}	Short circuit current	$V_I = 27\text{ V}$		500		mA
I_{scp}	Short circuit peak current			3		A

Refer to the test circuits, $T_J = 25\text{ °C}$, $V_I = 26\text{ V}$, $I_O = 500\text{ mA}$, unless otherwise specified.

Table 10. Electrical characteristics of L78S18

Symbol	Parameter	Test conditions	Min.	Typ.	Max.	Unit
V_O	Output voltage		17.1	18	18.9	V
V_O	Output voltage	$I_O = 1\text{ A}$, $V_I = 20.5\text{ V}$	17	18	19	V
ΔV_O	Line regulation	$V_I = 20.5\text{ to }30\text{ V}$			360	mV
		$V_I = 22\text{ to }28\text{ V}$			180	
ΔV_O	Load regulation	$I_O = 20\text{ mA to }2\text{ A}$			200	mV
I_Q	Quiescent current				8	mA
ΔI_Q	Quiescent current change	$I_O = 20\text{ mA to }1\text{ A}$			0.5	mA
		$V_I = 20.5\text{ to }30\text{ V}$, $I_O = 20\text{ mA}$			1	
$\Delta V_O/\Delta T$	Output voltage drift	$I_O = 5\text{ mA}$, $T_J = -55\text{ °C to }150\text{ °C}$		-1		mV/°C
eN	Output noise voltage	$B = 10\text{ Hz to }100\text{ kHz}$		110		μV
SVR	Supply voltage rejection	$f = 120\text{ Hz}$	49			dB
V_I	Operating input voltage	$I_O \leq 1.5\text{ A}$	21			V
R_O	Output resistance	$f = 1\text{ kHz}$		22		m Ω
I_{sc}	Short circuit current	$V_I = 27\text{ V}$		500		mA
I_{scp}	Short circuit peak current			3		A

Refer to the test circuits, $T_J = 25\text{ °C}$, $V_I = 33\text{ V}$, $I_O = 500\text{ mA}$, unless otherwise specified.

Table 11. Electrical characteristics of L78S24

Symbol	Parameter	Test conditions	Min.	Typ.	Max.	Unit
V_O	Output voltage		23	24	25	V
V_O	Output voltage	$I_O = 1\text{ A}$, $V_I = 27\text{ V}$	22.8	24	25.2	V
ΔV_O	Line regulation	$V_I = 27\text{ to }38\text{ V}$			480	mV
		$V_I = 30\text{ to }36\text{ V}$			240	
ΔV_O	Load regulation	$I_O = 20\text{ mA to }2\text{ A}$			250	mV
I_Q	Quiescent current				8	mA
ΔI_Q	Quiescent current change	$I_O = 20\text{ mA to }1\text{ A}$			0.5	mA
		$V_I = 27\text{ to }38\text{ V}$, $I_O = 20\text{ mA}$			1	
$\Delta V_O/\Delta T$	Output voltage drift	$I_O = 5\text{ mA}$, $T_J = -55\text{ °C to }150\text{ °C}$		-1.5		mV/°C
eN	Output noise voltage	B = 10 Hz to 100 kHz		170		μV
SVR	Supply voltage rejection	f = 120 Hz	48			dB
V_I	Operating input voltage	$I_O \leq 1.5\text{ A}$	27			V
R_O	Output resistance	f = 1 kHz		23		m Ω
I_{sc}	Short circuit current	$V_I = 27\text{ V}$		500		mA
I_{scp}	Short circuit peak current			3		A

Refer to the test circuits, $T_J = 25\text{ °C}$, $V_I = 10\text{ V}$, $I_O = 500\text{ mA}$, unless otherwise specified.

Table 12. Electrical characteristics of L78S05C

Symbol	Parameter	Test conditions	Min.	Typ.	Max.	Unit
V_O	Output voltage		4.8	5	5.2	V
V_O	Output voltage	$I_O = 1\text{ A}$, $V_I = 7\text{ V}$	4.75	5	5.25	V
ΔV_O	Line regulation	$V_I = 7\text{ to }25\text{ V}$			100	mV
		$V_I = 8\text{ to }25\text{ V}$			50	
ΔV_O	Load regulation	$I_O = 20\text{ mA to }1.5\text{ A}$			100	mV
		$I_O = 2\text{ A}$		80		
I_Q	Quiescent current				8	mA
ΔI_Q	Quiescent current change	$I_O = 20\text{ mA to }1\text{ A}$			0.5	mA
		$V_I = 7\text{ to }25\text{ V}$, $I_O = 20\text{ mA}$			1.3	
$\Delta V_O/\Delta T$	Output voltage drift	$I_O = 5\text{ mA}$, $T_J = 0\text{ °C to }70\text{ °C}$		-1.1		mV/°C
eN	Output noise voltage	$B = 10\text{ Hz to }100\text{ kHz}$		40		μV
SVR	Supply voltage rejection	$f = 120\text{ Hz}$	54			dB
V_I	Operating input voltage	$I_O \leq 1\text{ A}$	8			V
R_O	Output resistance	$f = 1\text{ kHz}$		17		m Ω
I_{sc}	Short circuit current	$V_I = 27\text{ V}$		500		mA
I_{scp}	Short circuit peak current			3		A

Refer to the test circuits, $T_J = 25\text{ °C}$, $V_I = 12.5\text{ V}$, $I_O = 500\text{ mA}$, unless otherwise specified.

Table 13. Electrical characteristics of L78S75C

Symbol	Parameter	Test conditions	Min.	Typ.	Max.	Unit
V_O	Output voltage		7.15	7.5	7.9	V
V_O	Output voltage	$I_O = 1\text{ A}$, $V_I = 9.5\text{ V}$	7.1	7.5	7.95	V
ΔV_O	Line regulation	$V_I = 9.5\text{ to }25\text{ V}$			120	mV
		$V_I = 10.5\text{ to }20\text{ V}$			60	
ΔV_O	Load regulation	$I_O = 20\text{ mA to }1.5\text{ A}$			140	mV
		$I_O = 2\text{ A}$		100		
I_Q	Quiescent current				8	mA
ΔI_Q	Quiescent current change	$I_O = 20\text{ mA to }1\text{ A}$			0.5	mA
		$V_I = 9.5\text{ to }25\text{ V}$, $I_O = 20\text{ mA}$			1.3	
$\Delta V_O/\Delta T$	Output voltage drift	$I_O = 5\text{ mA}$, $T_J = 0\text{ °C to }70\text{ °C}$		-0.8		mV/°C
eN	Output noise voltage	$B = 10\text{ Hz to }100\text{ kHz}$		52		μV
SVR	Supply voltage rejection	$f = 120\text{ Hz}$	48			dB
V_I	Operating input voltage	$I_O \leq 1\text{ A}$	10.5			V
R_O	Output resistance	$f = 1\text{ kHz}$		16		m Ω
I_{sc}	Short circuit current	$V_I = 27\text{ V}$		500		mA
I_{scp}	Short circuit peak current			3		A

Refer to the test circuits, $T_J = 25\text{ °C}$, $V_I = 14\text{ V}$, $I_O = 500\text{ mA}$, unless otherwise specified.

Table 14. Electrical characteristics of L78S09C

Symbol	Parameter	Test conditions	Min.	Typ.	Max.	Unit
V_O	Output voltage		8.65	9	9.35	V
V_O	Output voltage	$I_O = 1\text{ A}$, $V_I = 11\text{ V}$	8.6	9	9.4	V
ΔV_O	Line regulation	$V_I = 11\text{ to }25\text{ V}$			130	mV
		$V_I = 11\text{ to }20\text{ V}$			65	
ΔV_O	Load regulation	$I_O = 20\text{ mA to }1.5\text{ A}$			170	mV
		$I_O = 2\text{ A}$		100		
I_Q	Quiescent current				8	mA
ΔI_Q	Quiescent current change	$I_O = 20\text{ mA to }1\text{ A}$			0.5	mA
		$V_I = 11\text{ to }25\text{ V}$, $I_O = 20\text{ mA}$			1.3	
$\Delta V_O/\Delta T$	Output voltage drift	$I_O = 5\text{ mA}$, $T_J = 0\text{ °C to }70\text{ °C}$		-1		mV/°C
eN	Output noise voltage	$B = 10\text{ Hz to }100\text{ kHz}$		60		μV
SVR	Supply voltage rejection	$f = 120\text{ Hz}$	47			dB
V_I	Operating input voltage	$I_O \leq 1\text{ A}$	12			V
R_O	Output resistance	$f = 1\text{ kHz}$		17		m Ω
I_{sc}	Short circuit current	$V_I = 27\text{ V}$		500		mA
I_{scp}	Short circuit peak current			3		A

Refer to the test circuits, $T_J = 25\text{ °C}$, $V_I = 15\text{ V}$, $I_O = 500\text{ mA}$, unless otherwise specified.

Table 15. Electrical characteristics of L78S10C

Symbol	Parameter	Test conditions	Min.	Typ.	Max.	Unit
V_O	Output voltage		9.5	10	10.5	V
V_O	Output voltage	$I_O = 1\text{ A}$, $V_I = 12.5\text{ V}$	9.4	10	10.6	V
ΔV_O	Line regulation	$V_I = 12.5\text{ to }30\text{ V}$			200	mV
		$V_I = 14\text{ to }22\text{ V}$			100	
ΔV_O	Load regulation	$I_O = 20\text{ mA to }1.5\text{ A}$			240	mV
		$I_O = 2\text{ A}$		150		
I_Q	Quiescent current				8	mA
ΔI_Q	Quiescent current change	$I_O = 20\text{ mA to }1\text{ A}$			0.5	mA
		$V_I = 12.5\text{ to }30\text{ V}$, $I_O = 20\text{ mA}$			1	
$\Delta V_O/\Delta T$	Output voltage drift	$I_O = 5\text{ mA}$, $T_J = 0\text{ °C to }70\text{ °C}$		-1		mV/°C
eN	Output noise voltage	$B = 10\text{ Hz to }100\text{ kHz}$		65		μV
SVR	Supply voltage rejection	$f = 120\text{ Hz}$	47			dB
V_I	Operating input voltage	$I_O \leq 1\text{ A}$	13			V
R_O	Output resistance	$f = 1\text{ kHz}$		17		m Ω
I_{sc}	Short circuit current	$V_I = 27\text{ V}$		500		mA
I_{scp}	Short circuit peak current			3		A

Refer to the test circuits, $T_J = 25\text{ °C}$, $V_I = 19\text{ V}$, $I_O = 500\text{ mA}$, unless otherwise specified.

Table 16. Electrical characteristics of L78S12C

Symbol	Parameter	Test conditions	Min.	Typ.	Max.	Unit
V_O	Output voltage		11.5	12	12.5	V
V_O	Output voltage	$I_O = 1\text{ A}$, $V_I = 14.5\text{ V}$	11.4	12	12.6	V
ΔV_O	Line regulation	$V_I = 14.5\text{ to }30\text{ V}$			240	mV
		$V_I = 16\text{ to }22\text{ V}$			120	
ΔV_O	Load regulation	$I_O = 20\text{ mA to }1.5\text{ A}$			240	mV
		$I_O = 2\text{ A}$		150		
I_Q	Quiescent current				8	mA
ΔI_Q	Quiescent current change	$I_O = 20\text{ mA to }1\text{ A}$			0.5	mA
		$V_I = 14.5\text{ to }30\text{ V}$, $I_O = 20\text{ mA}$			1	
$\Delta V_O/\Delta T$	Output voltage drift	$I_O = 5\text{ mA}$, $T_J = 0\text{ °C to }70\text{ °C}$		-1		mV/°C
eN	Output noise voltage	B = 10 Hz to 100 kHz		75		μV
SVR	Supply voltage rejection	f = 120 Hz	47			dB
V_I	Operating input voltage	$I_O \leq 1\text{ A}$	15			V
R_O	Output resistance	f = 1 kHz		18		mΩ
I_{sc}	Short circuit current	$V_I = 27\text{ V}$		500		mA
I_{scp}	Short circuit peak current			3		A

Refer to the test circuits, $T_J = 25\text{ °C}$, $V_I = 23\text{ V}$, $I_O = 500\text{ mA}$, unless otherwise specified.

Table 17. Electrical characteristics of L78S15C

Symbol	Parameter	Test conditions	Min.	Typ.	Max.	Unit
V_O	Output voltage		14.4	15	15.6	V
V_O	Output voltage	$I_O = 1\text{ A}$, $V_I = 17.5\text{ V}$	14.25	15	15.75	V
ΔV_O	Line regulation	$V_I = 17.5\text{ to }30\text{ V}$			300	mV
		$V_I = 20\text{ to }26\text{ V}$			150	
ΔV_O	Load regulation	$I_O = 20\text{ mA to }1.5\text{ A}$			300	mV
		$I_O = 2\text{ A}$		150		
I_Q	Quiescent current				8	mA
ΔI_Q	Quiescent current change	$I_O = 20\text{ mA to }1\text{ A}$			0.5	mA
		$V_I = 17.5\text{ to }30\text{ V}$, $I_O = 20\text{ mA}$			1	
$\Delta V_O/\Delta T$	Output voltage drift	$I_O = 5\text{ mA}$, $T_J = 0\text{ °C to }70\text{ °C}$		-1		mV/°C
eN	Output noise voltage	B = 10 Hz to 100 kHz		90		μV
SVR	Supply voltage rejection	f = 120 Hz	46			dB
V_I	Operating input voltage	$I_O \leq 1\text{ A}$	18			V
R_O	Output resistance	f = 1 kHz		19		m Ω
I_{sc}	Short circuit current	$V_I = 27\text{ V}$		500		mA
I_{scp}	Short circuit peak current			3		A

Refer to the test circuits, $T_J = 25\text{ °C}$, $V_I = 26\text{ V}$, $I_O = 500\text{ mA}$, unless otherwise specified.

Table 18. Electrical characteristics of L78S18C

Symbol	Parameter	Test conditions	Min.	Typ.	Max.	Unit
V_O	Output voltage		17.1	18	18.9	V
V_O	Output voltage	$I_O = 1\text{ A}$, $V_I = 20.5\text{ V}$	17	18	19	V
ΔV_O	Line regulation	$V_I = 20.5\text{ to }30\text{ V}$			360	mV
		$V_I = 22\text{ to }28\text{ V}$			180	
ΔV_O	Load regulation	$I_O = 20\text{ mA to }1.5\text{ A}$			360	mV
		$I_O = 2\text{ A}$		200		
I_Q	Quiescent current				8	mA
ΔI_Q	Quiescent current change	$I_O = 20\text{ mA to }1\text{ A}$			0.5	mA
		$V_I = 20.5\text{ to }30\text{ V}$, $I_O = 20\text{ mA}$			1	
$\Delta V_O/\Delta T$	Output voltage drift	$I_O = 5\text{ mA}$, $T_J = 0\text{ °C to }70\text{ °C}$		-1		mV/°C
eN	Output noise voltage	$B = 10\text{ Hz to }100\text{ kHz}$		110		μV
SVR	Supply voltage rejection	$f = 120\text{ Hz}$	43			dB
V_I	Operating input voltage	$I_O \leq 1\text{ A}$	21			V
R_O	Output resistance	$f = 1\text{ kHz}$		22		m Ω
I_{sc}	Short circuit current	$V_I = 27\text{ V}$		500		mA
I_{scp}	Short circuit peak current			3		A

Refer to the test circuits, $T_J = 25\text{ °C}$, $V_I = 33\text{ V}$, $I_O = 500\text{ mA}$, unless otherwise specified.

Table 19. Electrical characteristics of L78S24C

Symbol	Parameter	Test conditions	Min.	Typ.	Max.	Unit
V_O	Output voltage		23	24	25	V
V_O	Output voltage	$I_O = 1\text{ A}$, $V_I = 27\text{ V}$	22.8	24	25.2	V
ΔV_O	Line regulation	$V_I = 27\text{ to }38\text{ V}$			480	mV
		$V_I = 30\text{ to }36\text{ V}$			240	
ΔV_O	Load regulation	$I_O = 20\text{ mA to }1.5\text{ A}$			480	mV
		$I_O = 2\text{ A}$		300		
I_Q	Quiescent current				8	mA
ΔI_Q	Quiescent current change	$I_O = 20\text{ mA to }1\text{ A}$			0.5	mA
		$V_I = 27\text{ to }38\text{ V}$, $I_O = 20\text{ mA}$			1	
$\Delta V_O/\Delta T$	Output voltage drift	$I_O = 5\text{ mA}$, $T_J = 0\text{ °C to }70\text{ °C}$		-1.5		mV/°C
eN	Output noise voltage	$B = 10\text{ Hz to }100\text{ kHz}$		170		μV
SVR	Supply voltage rejection	$f = 120\text{ Hz}$	42			dB
V_I	Operating input voltage	$I_O \leq 1\text{ A}$	27			V
R_O	Output resistance	$f = 1\text{ kHz}$		28		m Ω
I_{sc}	Short circuit current	$V_I = 27\text{ V}$		500		mA
I_{scp}	Short circuit peak current			3		A

6 Typical performance

Figure 8. Dropout voltage vs. junction temperature

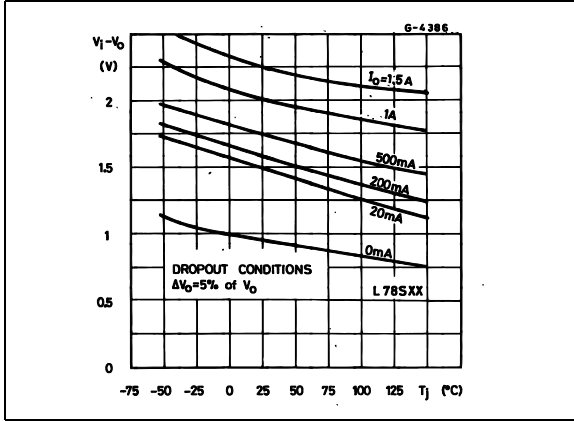

Figure 9. Peak output current vs. input/output differential voltage

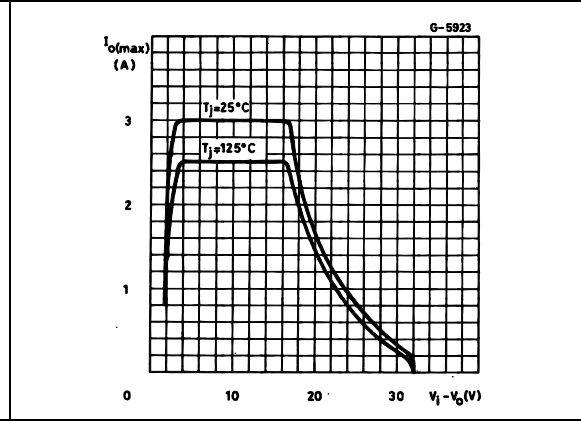

Figure 10. Output impedance vs. frequency

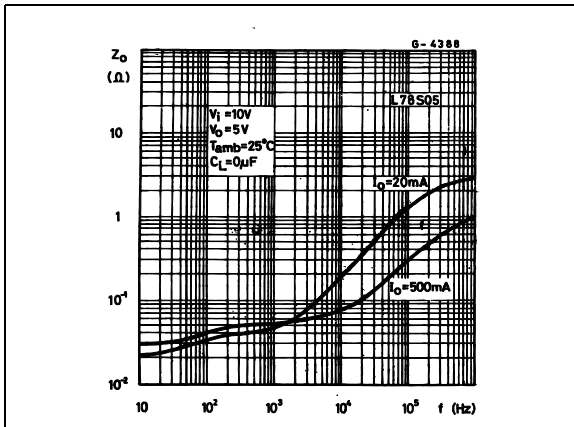

Figure 11. Output voltage vs. junction temperature

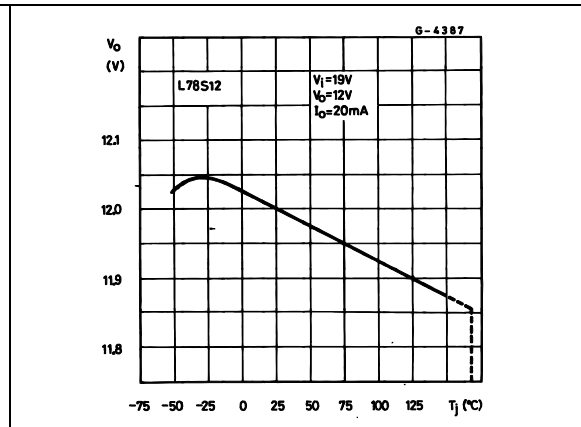

Figure 12. Supply voltage rejection vs. frequency

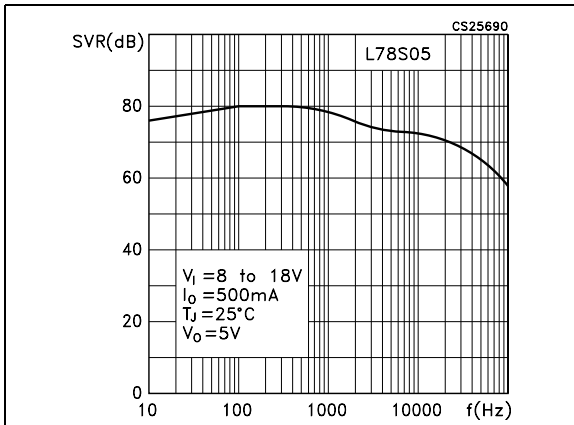

Figure 13. Quiescent current vs. junction temperature

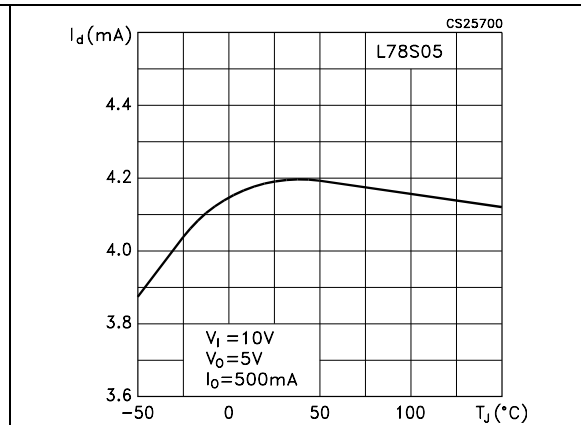

Figure 14. Load transient response

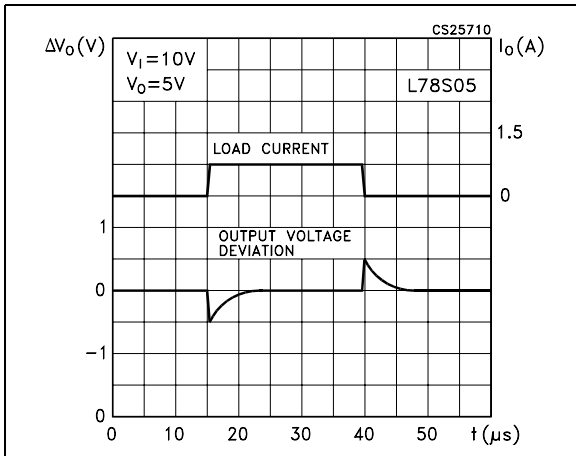

Figure 15. Line transient response

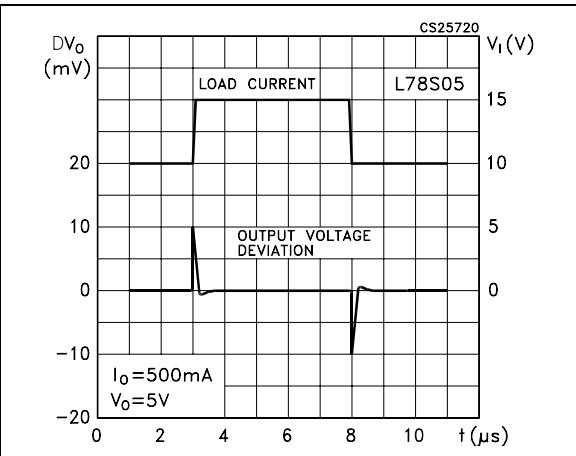

Figure 16. Quiescent current vs. input voltage

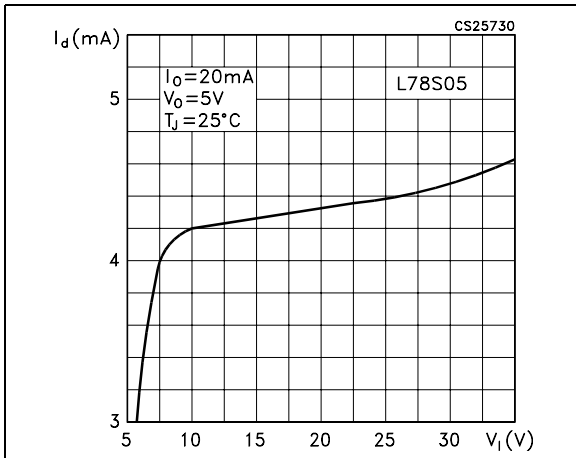
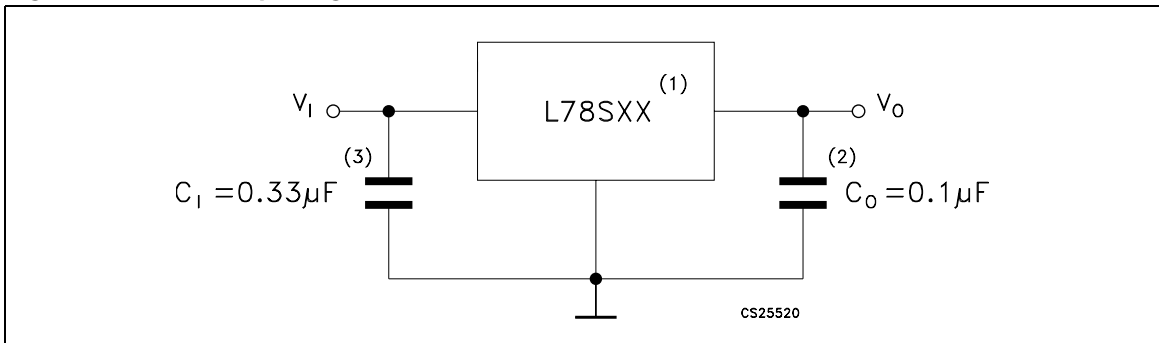

Figure 17. Fixed output regulator



1. To specify an output voltage, substitute voltage value for "XX".
2. Although no output capacitor is need for stability, it does improve transient response.
3. Required if regulator is locate an appreciable distance from power supply filter.

Figure 18. Constant current regulator

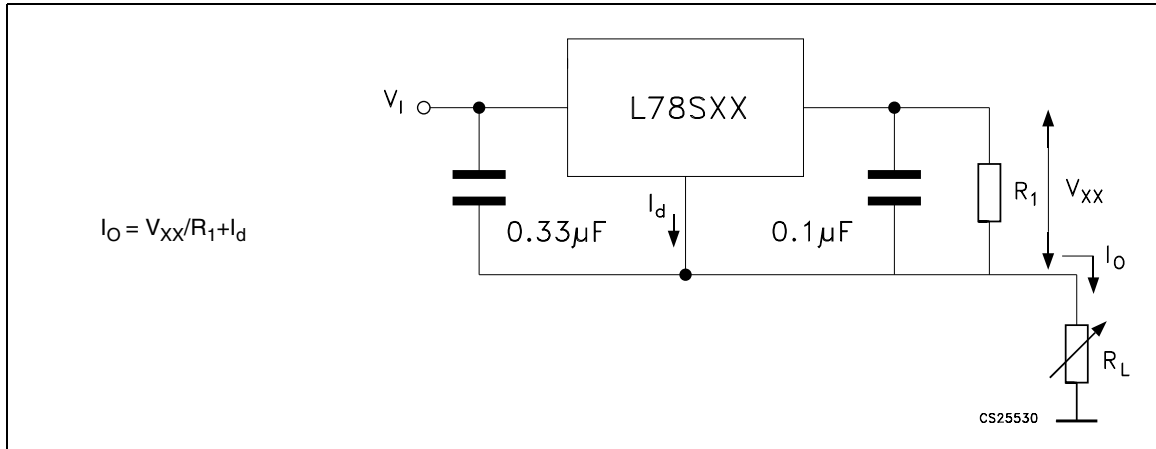

Figure 19. Circuit for increasing output voltage

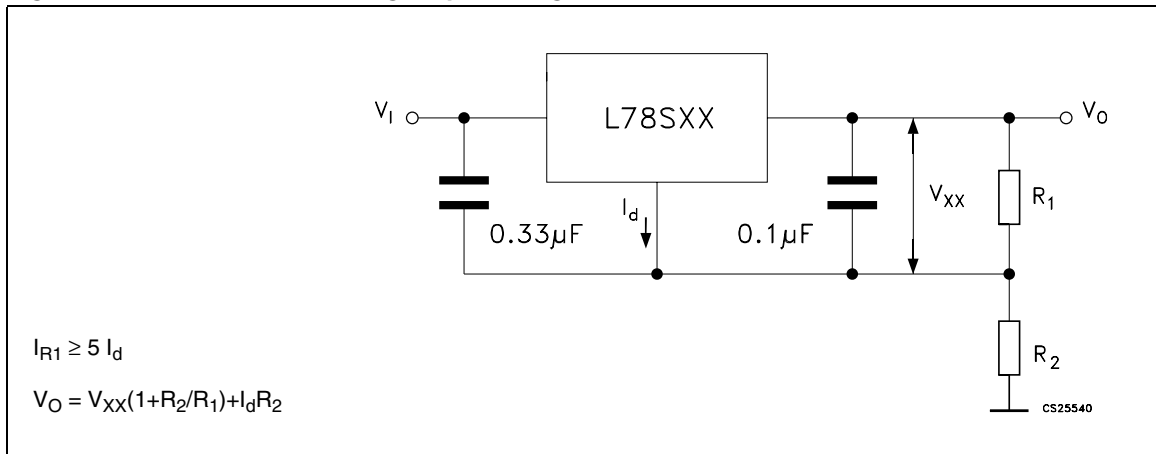

Figure 20. Adjustable output regulator (7 to 30 V)

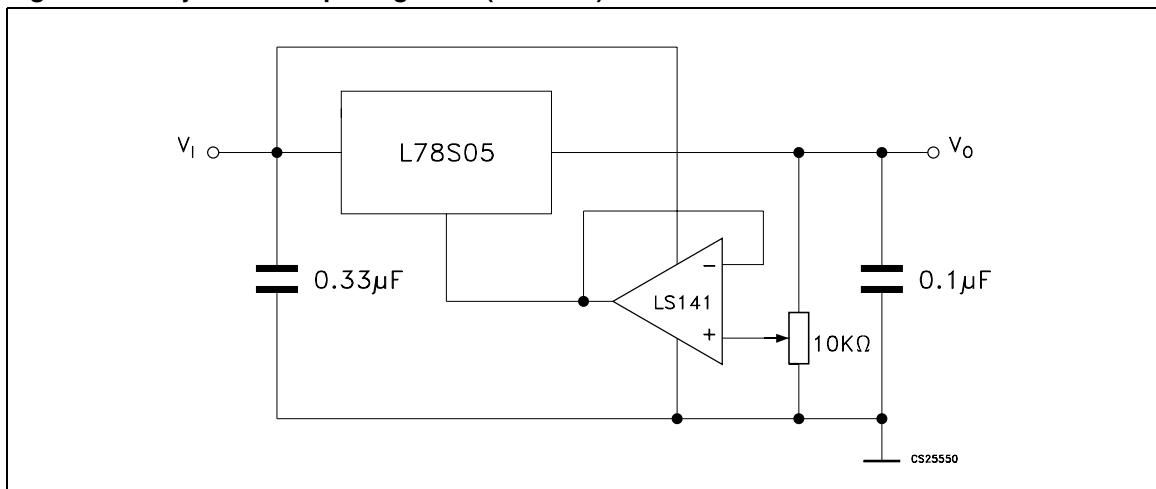

Figure 21. 0.5 to 10 V regulator

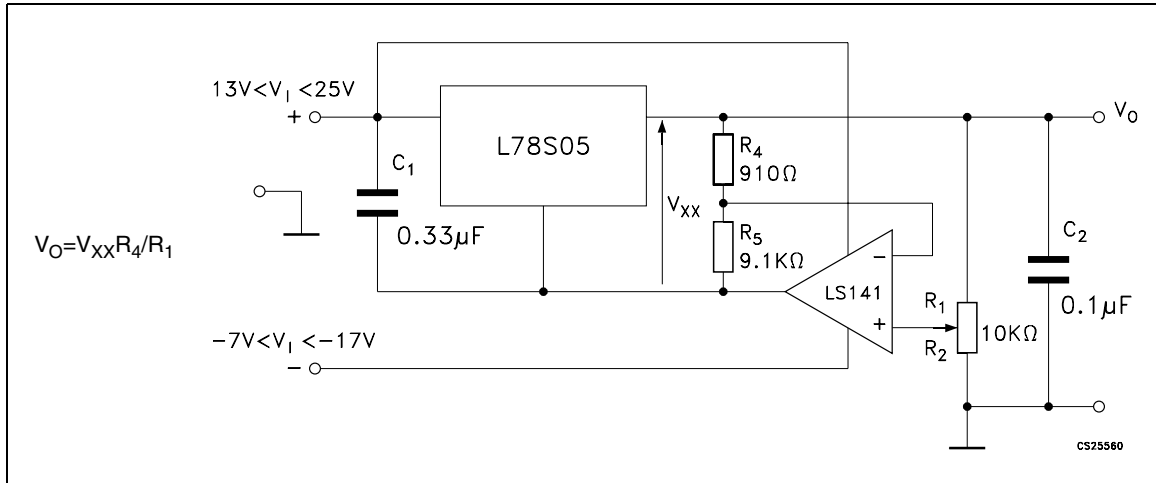

Figure 22. High current voltage regulator

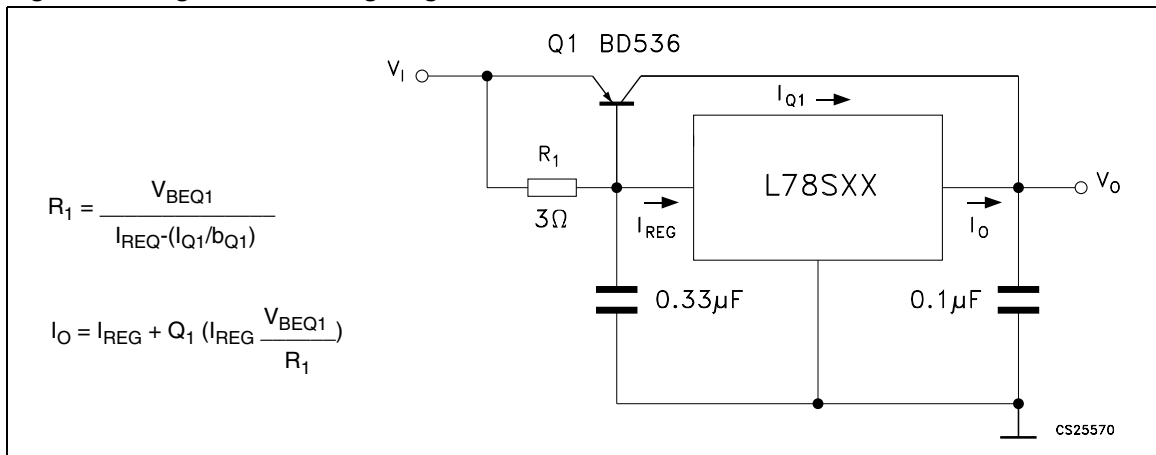

Figure 23. High output current with short circuit protection

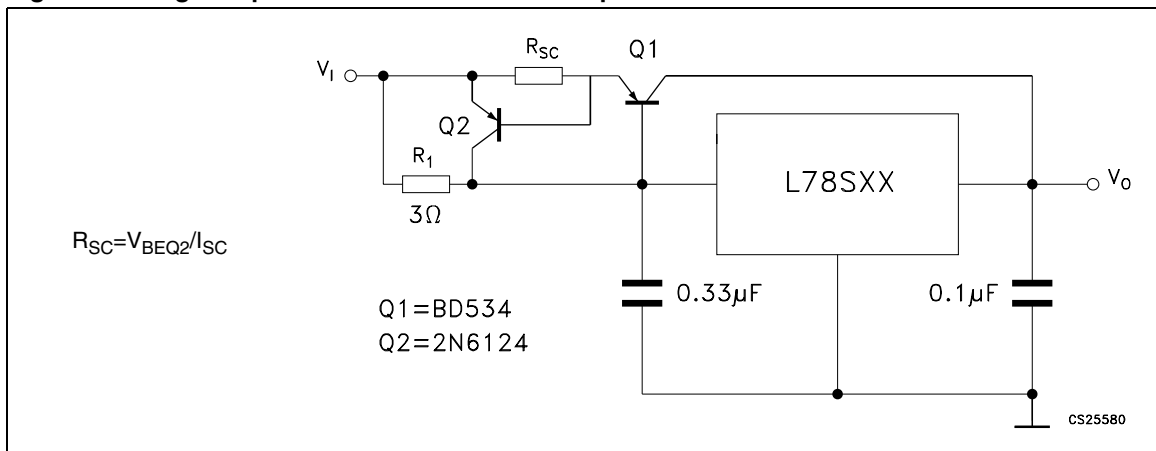

Figure 24. Tracking voltage regulator

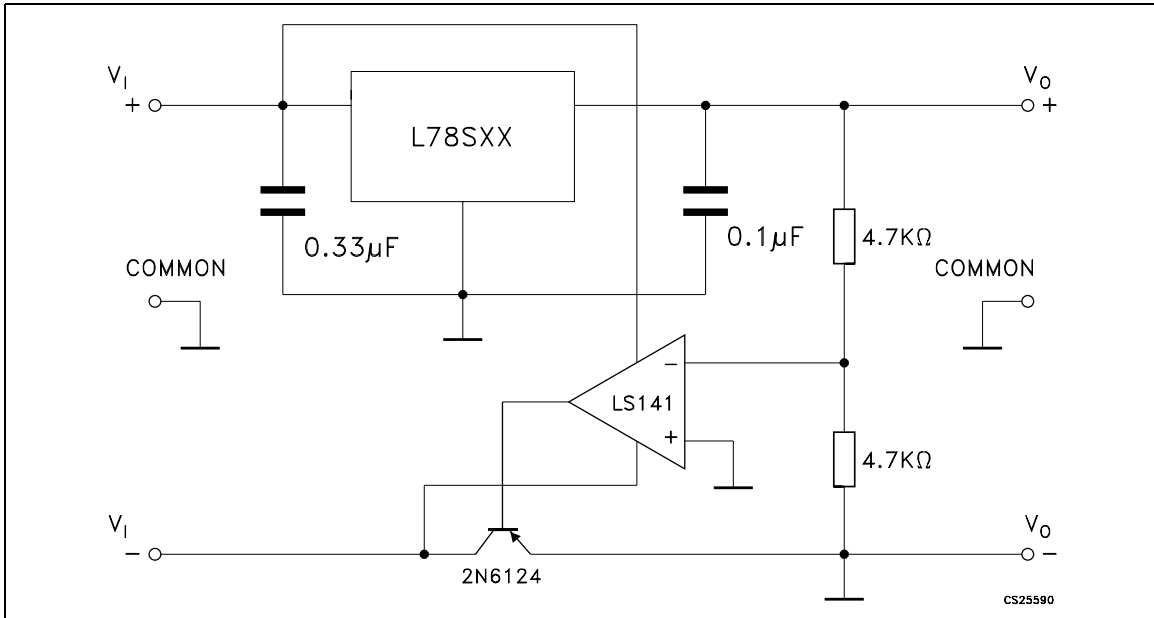

Figure 25. Positive and negative regulator

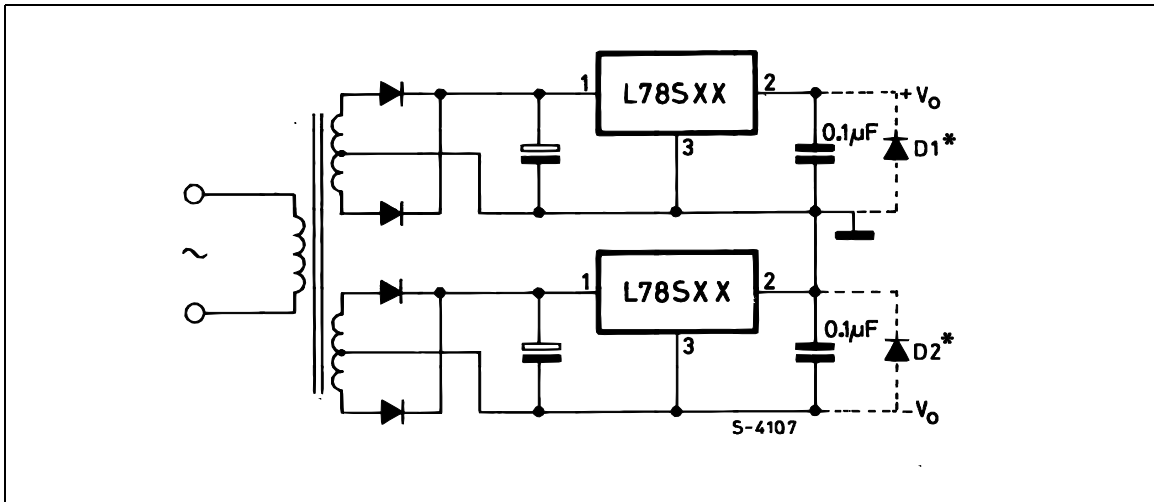

Figure 26. Negative output voltage circuit

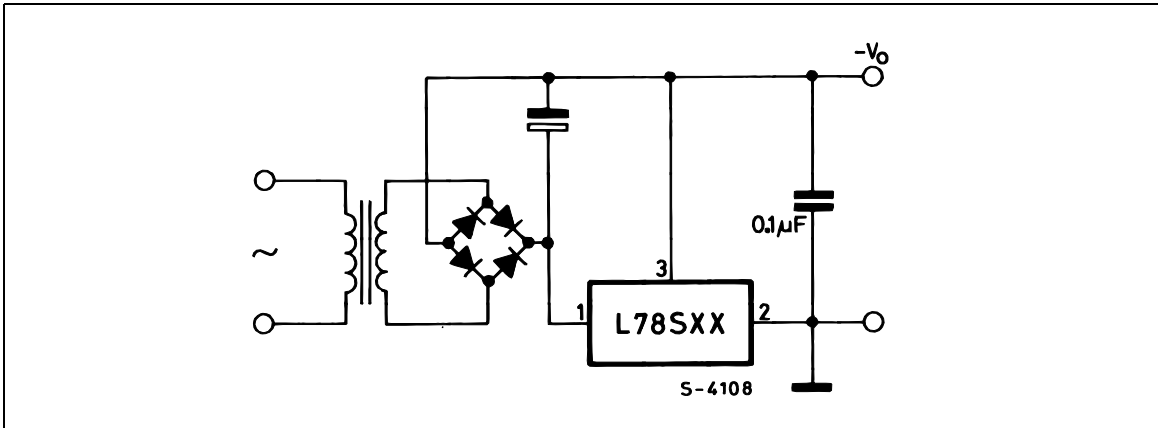

Figure 27. Switching regulator

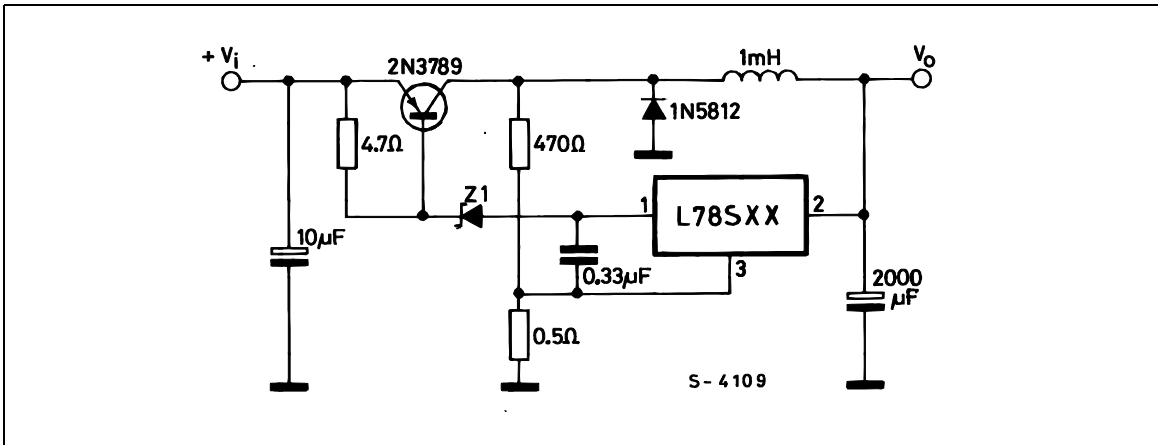

Figure 28. High input voltage circuit

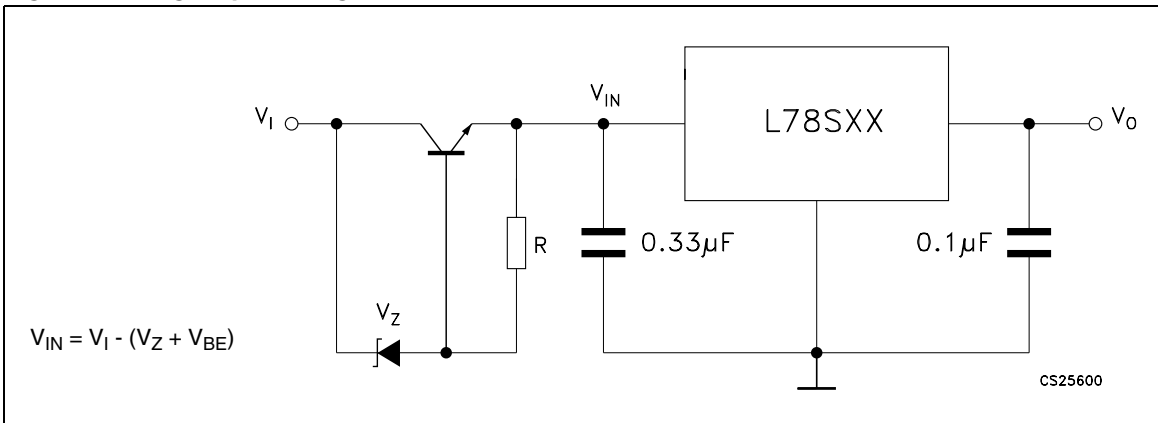

Figure 29. High input voltage circuit

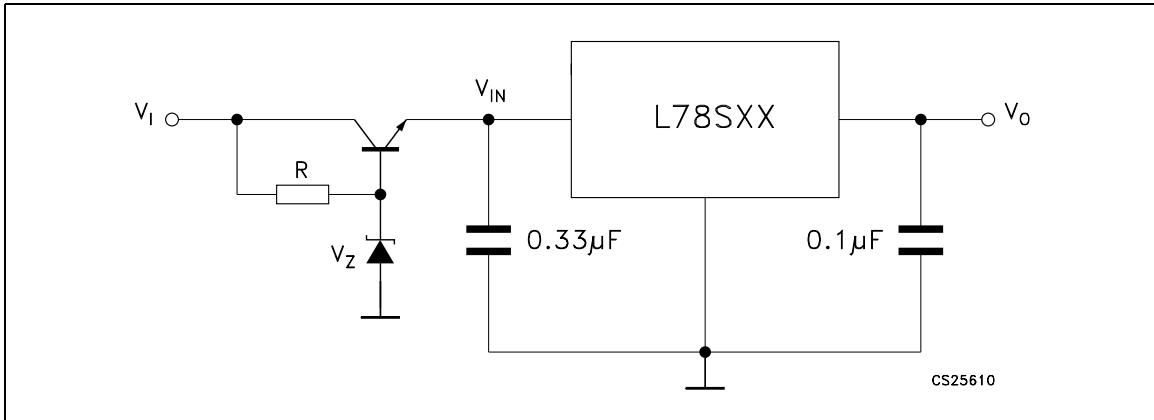

Figure 30. High output voltage regulator

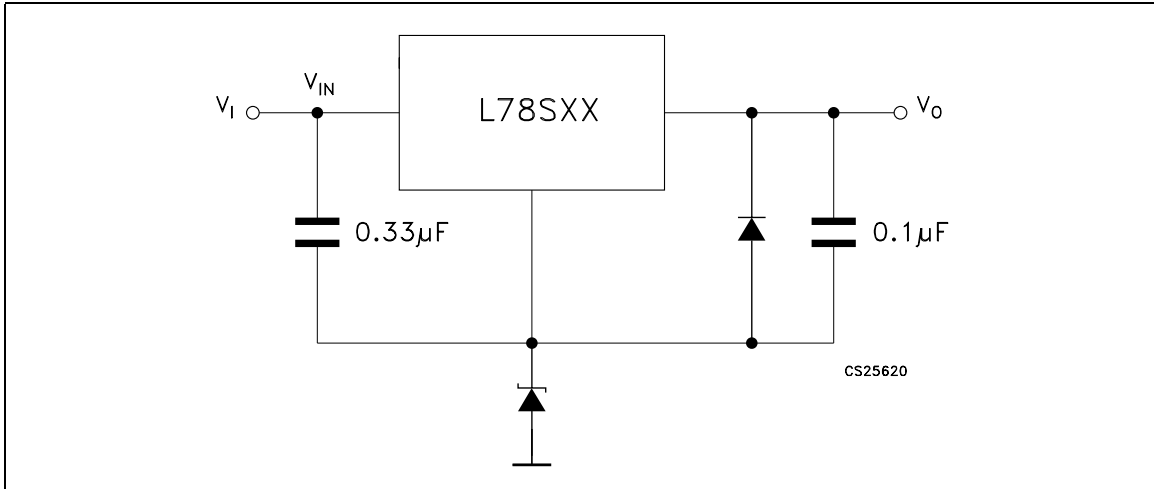

Figure 31. High input and output voltage

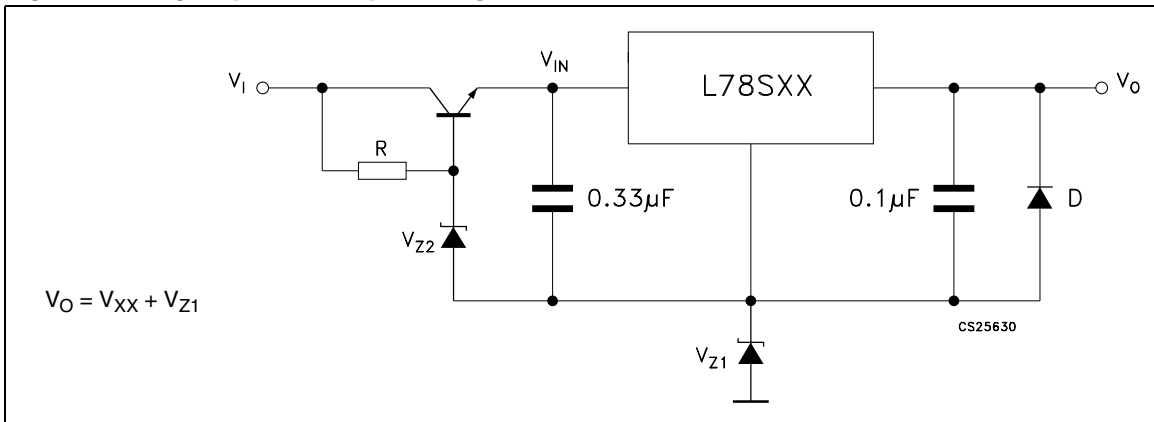

Figure 32. Reducing power dissipation with dropping resistor

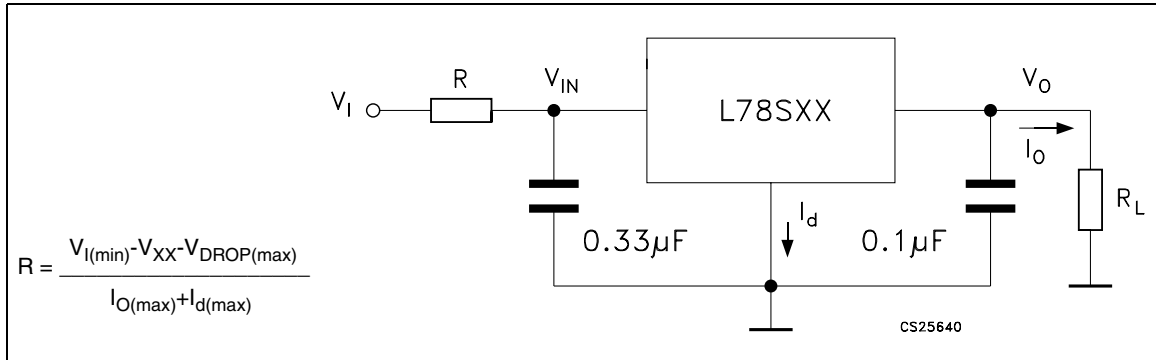

Figure 33. Remote shutdown

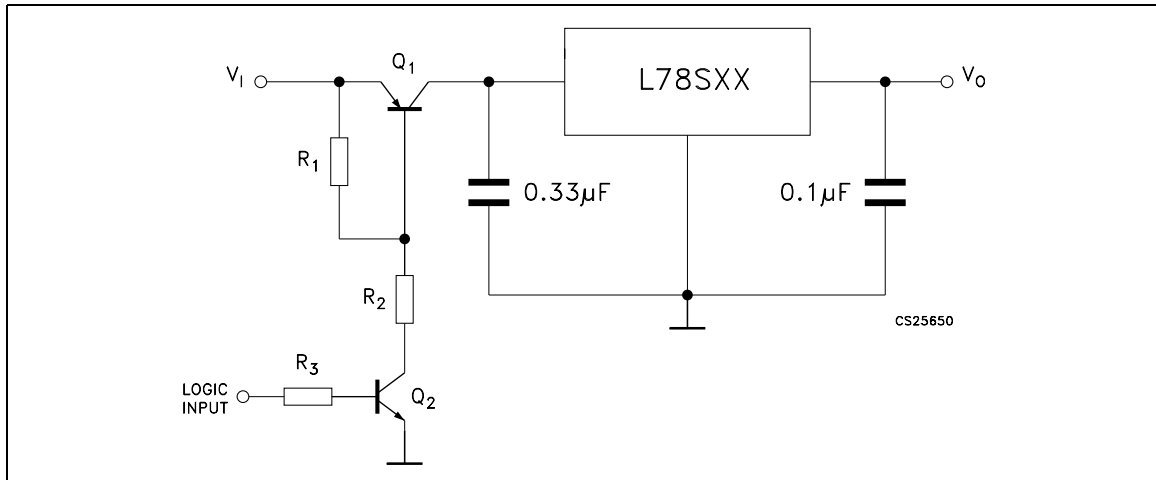
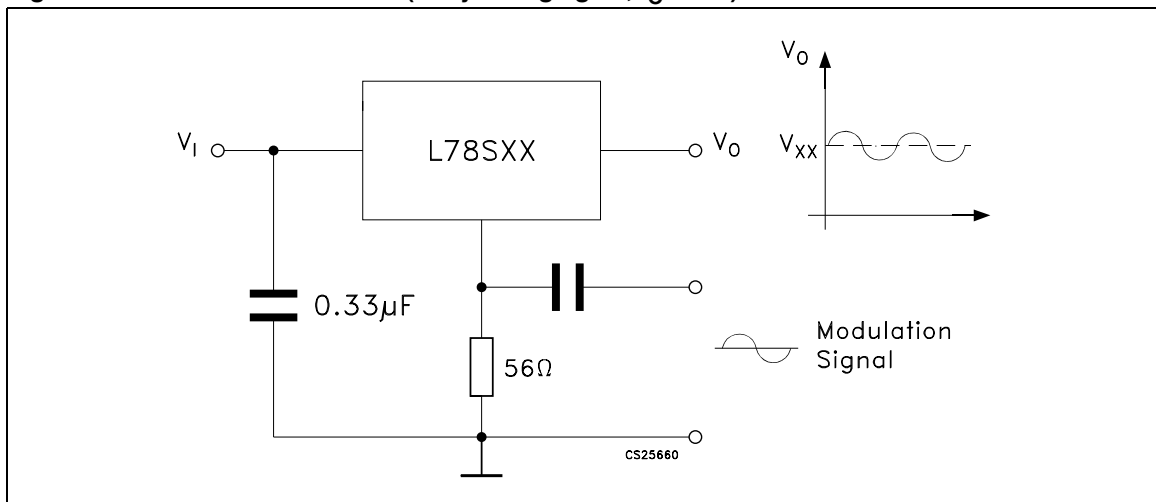
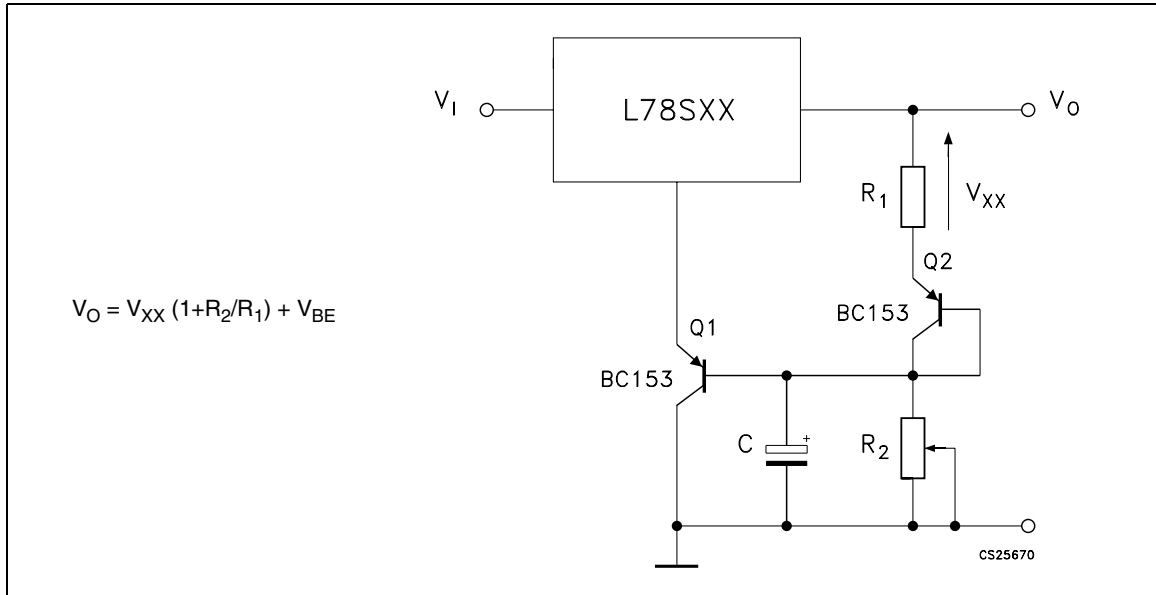

Figure 34. Power AM modulator (unity voltage gain, $I_O \leq 1\text{ A}$)



Note: The circuit performs well up to 100 kHz.

Figure 35. Adjustable output voltage with temperature compensation



Note: Q_2 is connected as a diode in order to compensate the variation of the Q_1 V_{BE} with the temperature. C allows a slow rise time of the V_O .

Figure 36. Light controllers ($V_{Omin} = V_{XX} + V_{BE}$)

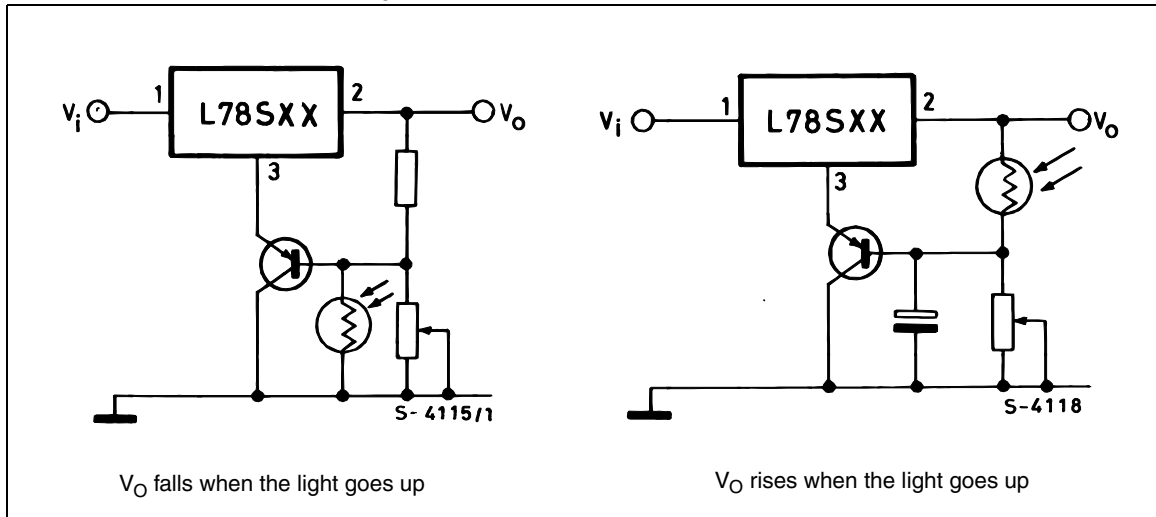
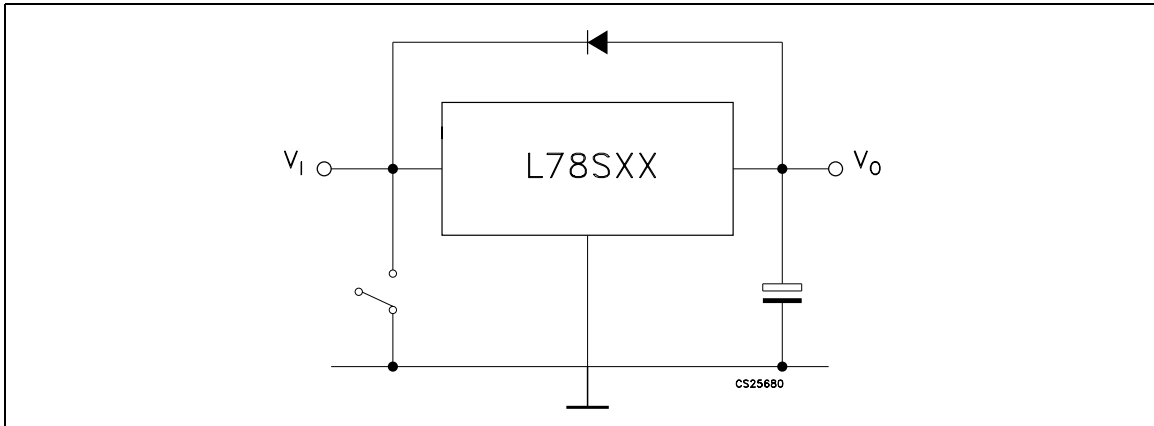

Figure 37. Protection against input short-circuit with high capacitance loads

1. Application with high capacitance loads and an output voltage greater than 6 volts need an external diode (see [Figure 30 on page 28](#)) to protect the device against input short circuit. In this case the input voltage falls rapidly while the output voltage decrease slowly. The capacitance discharges by means of the Base-Emitter junction of the series pass transistor in the regulator. If the energy is sufficiently high, the transistor may be destroyed. The external diode by-passes the current from the IC to ground.

7 Package mechanical data

In order to meet environmental requirements, ST offers these devices in different grades of ECOPACK[®] packages, depending on their level of environmental compliance. ECOPACK[®] specifications, grade definitions and product status are available at: www.st.com. ECOPACK[®] is an ST trademark.

Table 20. TO-220 mechanical data

Dim.	Type STD - ST Dual Gauge			Type STD - ST Single Gauge		
	mm.			mm.		
	Min.	Typ.	Max.	Min.	Typ.	Max.
A	4.40		4.60	4.40		4.60
b	0.61		0.88	0.61		0.88
b1	1.14		1.70	1.14		1.70
c	0.48		0.70	0.48		0.70
D	15.25		15.75	15.25		15.75
D1		1.27				
E	10.00		10.40	10.00		10.40
e	2.40		2.70	2.40		2.70
e1	4.95		5.15	4.95		5.15
F	1.23		1.32	0.51		0.60
H1	6.20		6.60	6.20		6.60
J1	2.40		2.72	2.40		2.72
L	13.00		14.00	13.00		14.00
L1	3.50		3.93	3.50		3.93
L20		16.40			16.40	
L30		28.90			28.90	
ØP	3.75		3.85	3.75		3.85
Q	2.65		2.95	2.65		2.95

In spite of some difference in tolerances, the packages are compatible.

Figure 38. Drawing dimension TO-220 (type STD-ST Dual Gauge)

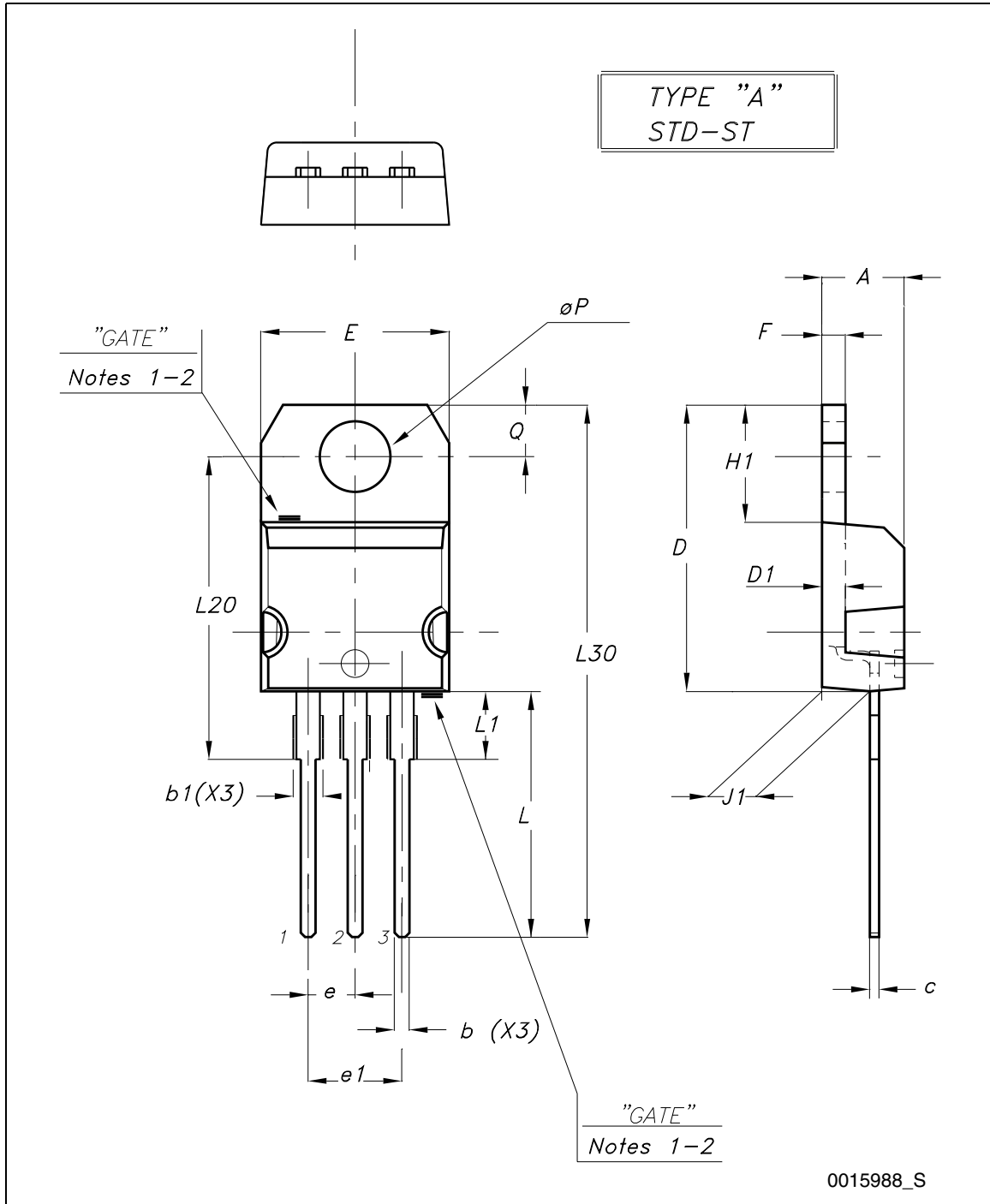

- Note: 1 Maximum resin gate protrusion: 0.5 mm.
 2 Resin gate position is accepted in each of the two positions shown on the drawing, or their symmetrical.

Figure 39. Drawing dimension TO-220 (type STD-ST Single Gauge)

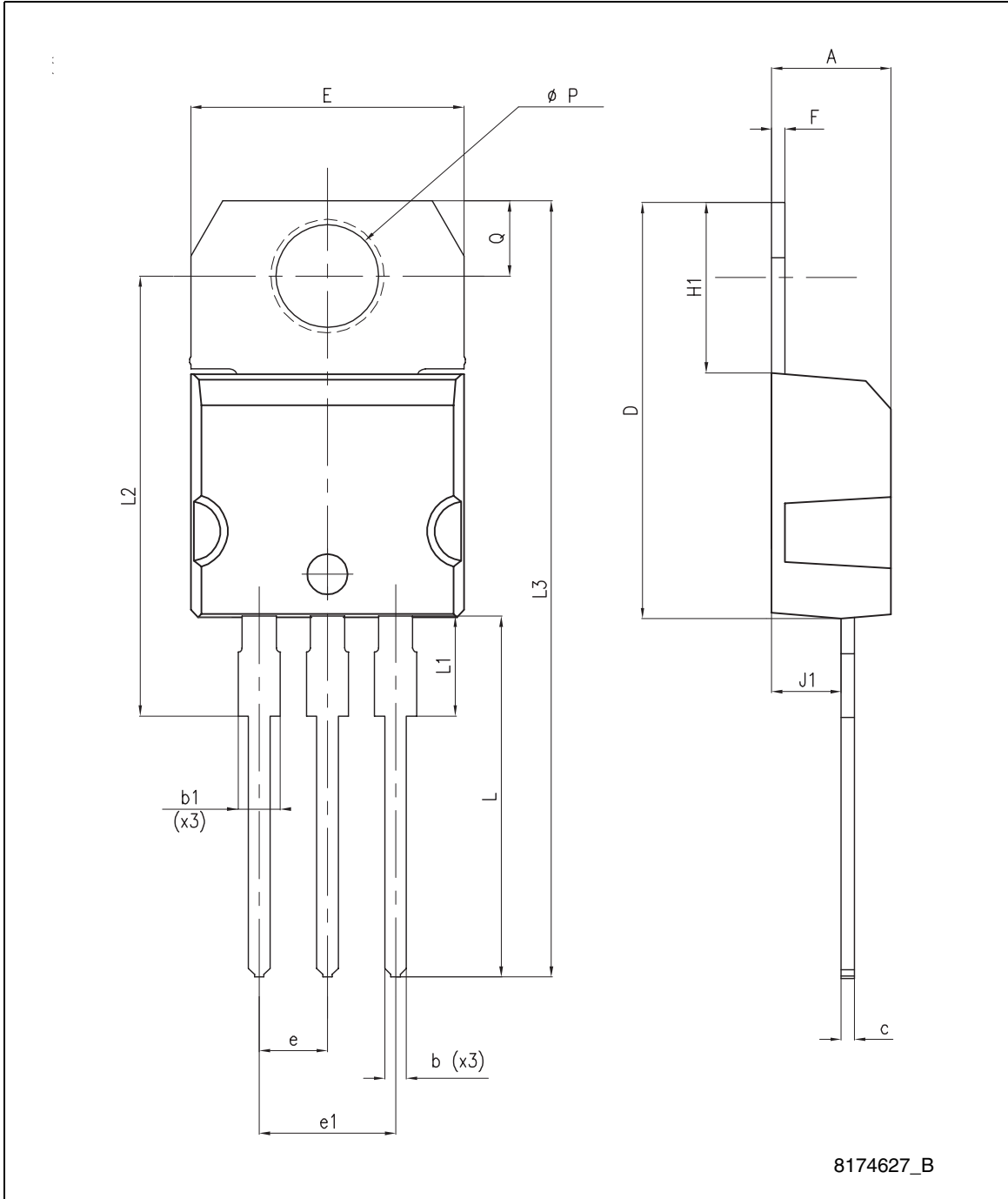

Figure 40. Drawing dimension tube for TO-220 Dual Gauge (mm.)

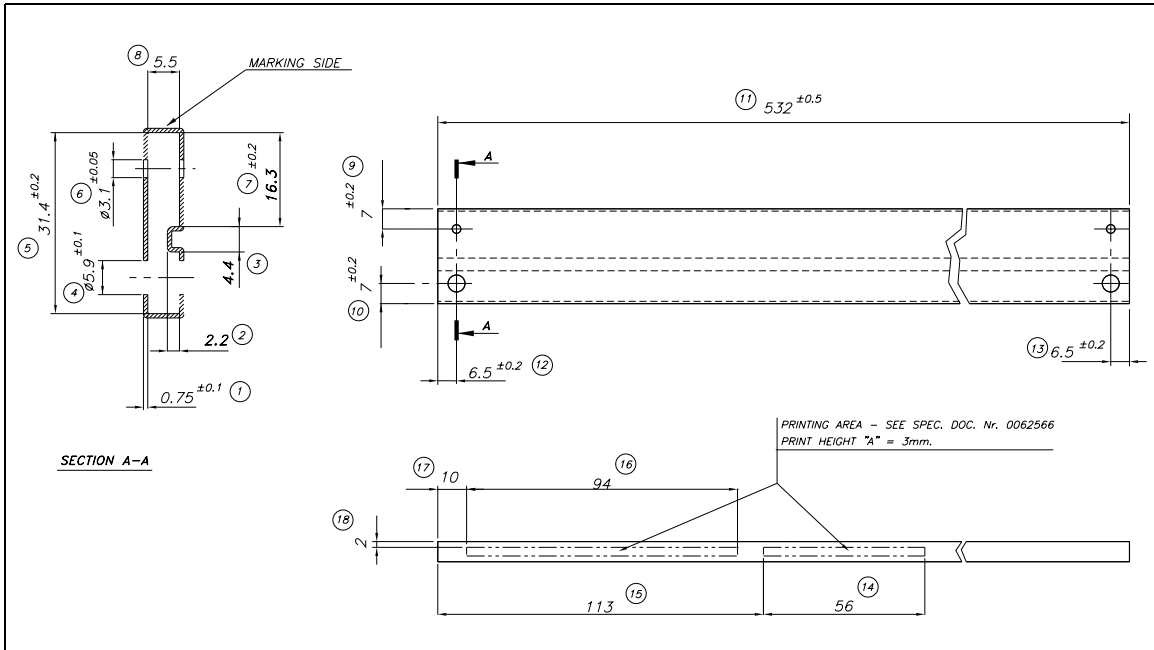
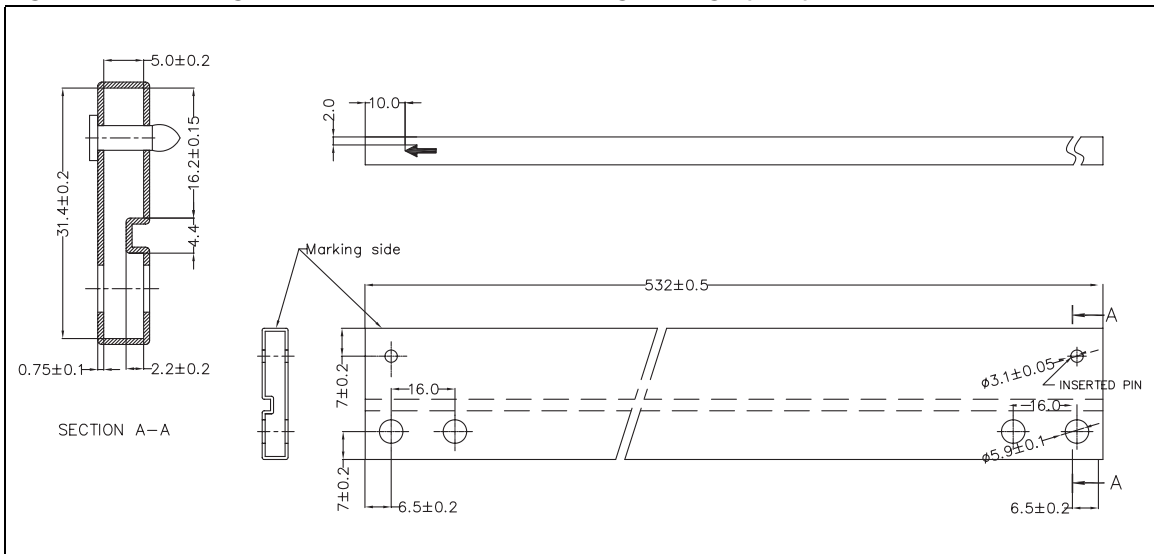
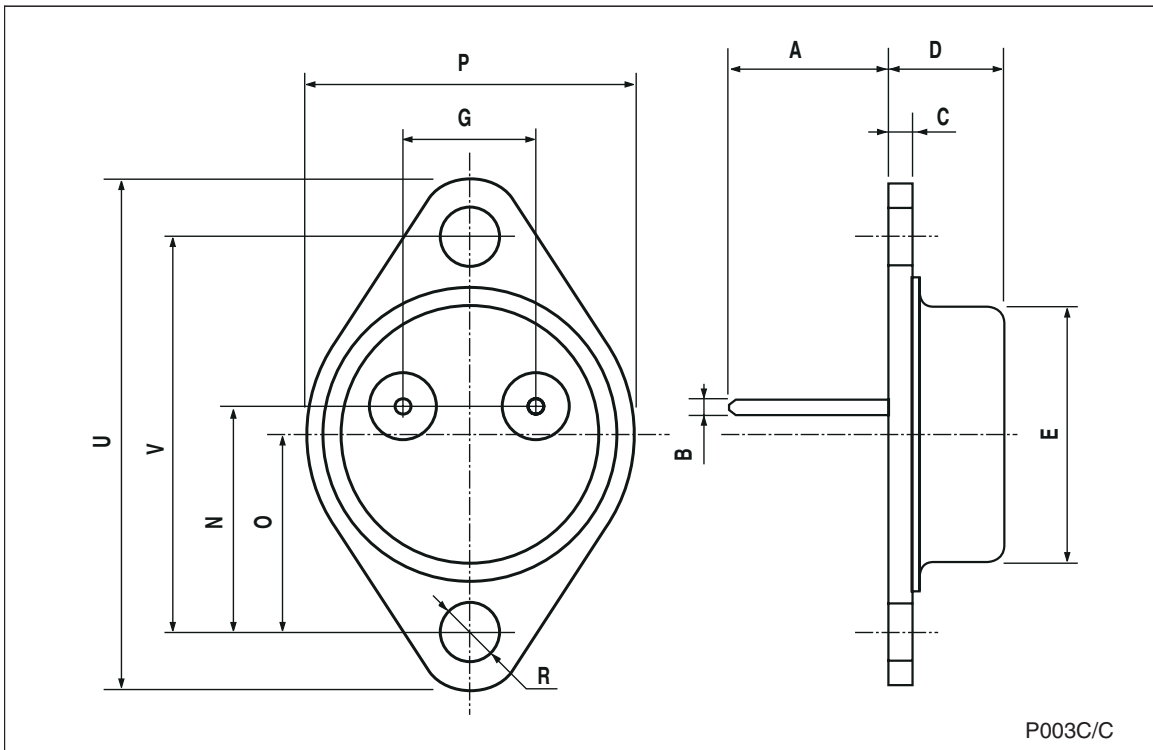

Figure 41. Drawing dimension tube for TO-220 Single Gauge (mm.)



TO-3 mechanical data

Dim.	mm.			inch.		
	Min.	Typ.	Max.	Min.	Typ.	Max.
A		11.85			0.466	
B	0.96	1.05	1.10	0.037	0.041	0.043
C			1.70			0.066
D			8.7			0.342
E			20.0			0.787
G		10.9			0.429	
N		16.9			0.665	
P			26.2			1.031
R	3.88		4.09	0.152		0.161
U			39.5			1.555
V		30.10			1.185	



8 Order codes

Table 21. Order codes

Part numbers	Packages		Output voltage
	TO-220	T0-3	
L78S05		L78S05T ⁽¹⁾	5 V
L78S05C	L78S05CV	L78S05CT ⁽¹⁾	5 V
L78S75		L78S75T ⁽¹⁾	7.5 V
L78S75C	L78S75CV	L78S75CT ⁽¹⁾	7.5 V
L78S09		L78S09T ⁽¹⁾	9 V
L78S09C	L78S09CV		9 V
L78S10		L78S10T ⁽¹⁾	10 V
L78S10C	L78S10CV	L78S10CT ⁽¹⁾	10 V
L78S12		L78S12T ⁽¹⁾	12 V
L78S12C	L78S12CV	L78S12CT	12 V
L78S15		L78S15T ⁽¹⁾	15 V
L78S15C	L78S15CV		15 V
L78S18		L78S18T ⁽¹⁾	18 V
L78S18C	L78S18CV		18 V
L78S24		L78S24T ⁽¹⁾	24 V
L78S24C	L78S24CV	L78S24CT ⁽¹⁾	24 V

1. Available on request.

9 Revision history

Table 22. Document revision history

Date	Revision	Changes
07-Sep-2006	2	Order codes updated.
20-Mar-2008	3	Added: Table 1 on page 1 .
22-Mar-2010	4	Added: Table 20 on page 32 , Figure 38 on page 33 , Figure 39 on page 34 , Figure 40 and Figure 41 on page 35 .

Please Read Carefully:

Information in this document is provided solely in connection with ST products. STMicroelectronics NV and its subsidiaries ("ST") reserve the right to make changes, corrections, modifications or improvements, to this document, and the products and services described herein at any time, without notice.

All ST products are sold pursuant to ST's terms and conditions of sale.

Purchasers are solely responsible for the choice, selection and use of the ST products and services described herein, and ST assumes no liability whatsoever relating to the choice, selection or use of the ST products and services described herein.

No license, express or implied, by estoppel or otherwise, to any intellectual property rights is granted under this document. If any part of this document refers to any third party products or services it shall not be deemed a license grant by ST for the use of such third party products or services, or any intellectual property contained therein or considered as a warranty covering the use in any manner whatsoever of such third party products or services or any intellectual property contained therein.

UNLESS OTHERWISE SET FORTH IN ST'S TERMS AND CONDITIONS OF SALE ST DISCLAIMS ANY EXPRESS OR IMPLIED WARRANTY WITH RESPECT TO THE USE AND/OR SALE OF ST PRODUCTS INCLUDING WITHOUT LIMITATION IMPLIED WARRANTIES OF MERCHANTABILITY, FITNESS FOR A PARTICULAR PURPOSE (AND THEIR EQUIVALENTS UNDER THE LAWS OF ANY JURISDICTION), OR INFRINGEMENT OF ANY PATENT, COPYRIGHT OR OTHER INTELLECTUAL PROPERTY RIGHT.

UNLESS EXPRESSLY APPROVED IN WRITING BY AN AUTHORIZED ST REPRESENTATIVE, ST PRODUCTS ARE NOT RECOMMENDED, AUTHORIZED OR WARRANTED FOR USE IN MILITARY, AIR CRAFT, SPACE, LIFE SAVING, OR LIFE SUSTAINING APPLICATIONS, NOR IN PRODUCTS OR SYSTEMS WHERE FAILURE OR MALFUNCTION MAY RESULT IN PERSONAL INJURY, DEATH, OR SEVERE PROPERTY OR ENVIRONMENTAL DAMAGE. ST PRODUCTS WHICH ARE NOT SPECIFIED AS "AUTOMOTIVE GRADE" MAY ONLY BE USED IN AUTOMOTIVE APPLICATIONS AT USER'S OWN RISK.

Resale of ST products with provisions different from the statements and/or technical features set forth in this document shall immediately void any warranty granted by ST for the ST product or service described herein and shall not create or extend in any manner whatsoever, any liability of ST.

ST and the ST logo are trademarks or registered trademarks of ST in various countries.

Information in this document supersedes and replaces all information previously supplied.

The ST logo is a registered trademark of STMicroelectronics. All other names are the property of their respective owners.

© 2010 STMicroelectronics - All rights reserved

STMicroelectronics group of companies

Australia - Belgium - Brazil - Canada - China - Czech Republic - Finland - France - Germany - Hong Kong - India - Israel - Italy - Japan - Malaysia - Malta - Morocco - Philippines - Singapore - Spain - Sweden - Switzerland - United Kingdom - United States of America

www.st.com

