

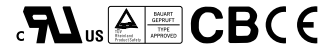

■ Features :

- Isolated output & GND for CH1,CH2,CH3
- Universal AC input/Full range
- Protections: Short circuit / Overload / Over voltage
- LED indicator for power on
- 100% full load burn-in test
- Fixed switching frequency at 67KHz
- 2 years warranty



SPECIFICATION

MODEL	IT-60D			IT-60F			
OUTPUT	OUTPUT	CH1	CH2	CH3	CH1	CH2	CH3
	DC VOLTAGE	5V	12V	24V	5V	15V	24V
	RATED CURRENT	3A	0.8A	1.4A	3A	0.8A	1.3A
	CURRENT RANGE	0.5 ~ 3A	0.1 ~ 1A	0.2 ~ 2A	0.5 ~ 3A	0.1 ~ 1A	0.2 ~ 2A
	RATED POWER	58.2W			58.2W		
	PEAK LOAD (3sec.) Note.4	70W					
	RIPPLE & NOISE (max.) Note.2	80mVp-p	120mVp-p	240mVp-p	80mVp-p	150mVp-p	240mVp-p
	VOLTAGE ADJ. RANGE	CH1 : 4.75 ~ 5.5V			CH1 : 4.75 ~ 5.5V		
	VOLTAGE TOLERANCE Note.3	±3.0%	±8.0%	±8.0%	±3.0%	±8.0%	±8.0%
	LINE REGULATION	±1.0%	±2.0%	±2.0%	±1.0%	±2.0%	±2.0%
	LOAD REGULATION	±2.0%	±5.0%	±5.0%	±2.0%	±5.0%	±5.0%
SETUP, RISE TIME	300ms, 20ms/230VAC 800ms, 20ms/115VAC at full load						
HOLD UP TIME (Typ.)	80ms/230VAC 18ms/115VAC at full load						
INPUT	VOLTAGE RANGE	90 ~ 264VAC		127 ~ 370VDC			
	FREQUENCY RANGE	47 ~ 63Hz					
	EFFICIENCY(Typ.)	76%					
	AC CURRENT (Typ.)	1.8A/115VAC		0.9A/230VAC			
	INRUSH CURRENT (Typ.)	COLD START 20A/115VAC		40A/230VAC			
LEAKAGE CURRENT	<1mA / 240VAC						
PROTECTION	OVERLOAD	72 ~ 90W rated output power Protection type : Hiccup mode, recovers automatically after fault condition is removed					
	OVER VOLTAGE	5V: 5.75 ~ 6.75V Protection type : Hiccup mode, recovers automatically after fault condition is removed					
ENVIRONMENT	WORKING TEMP.	-10 ~ +60°C (Refer to output load derating curve)					
	WORKING HUMIDITY	20 ~ 90% RH non-condensing					
	STORAGE TEMP., HUMIDITY	-20 ~ +85°C, 10 ~ 95% RH					
	TEMP. COEFFICIENT	±0.03%/°C (0 ~ 50°C) on +5V output					
VIBRATION	10 ~ 500Hz, 2G 10min./1cycle, period for 60min. each along X, Y, Z axes						
SAFETY & EMC (Note 5)	SAFETY STANDARDS	UL60950-1, TUV EN60950-1 approved					
	WITHSTAND VOLTAGE	I/P-O/P:3KVAC I/P-FG:1.5KVAC O/P-FG:0.5KVAC					
	ISOLATION RESISTANCE	I/P-O/P, I/P-FG, O/P-FG:100M Ohms / 500VDC / 25°C / 70% RH					
	EMI CONDUCTION & RADIATION	Compliance to EN55022 (CISPR22) Class B					
	HARMONIC CURRENT	Compliance to EN61000-3-2,-3					
EMS IMMUNITY	Compliance to EN61000-4-2,3,4,5,6,8,11, ENV50204, EN55024, light industry level, criteria A						
OTHERS	MTBF	314.3K hrs min. MIL-HDBK-217F (25°C)					
	DIMENSION	159*97*38mm (L*W*H)					
	PACKING	0.51Kg; 24pcs/13.2Kg/0.75CUFT					
NOTE	<p>1. All parameters NOT specially mentioned are measured at 230VAC input, rated load and 25°C of ambient temperature.</p> <p>2. Ripple & noise are measured at 20MHz of bandwidth by using a 12" twisted pair-wire terminated with a 0.1uf & 47uf parallel capacitor.</p> <p>3. Tolerance : includes set up tolerance, line regulation and load regulation.</p> <p>4. 5% Duty cycle maximum within every 1min. Average output power should not exceed the rated power.</p> <p>5. The power supply is considered a component which will be installed into a final equipment. The final equipment must be re-confirmed that it still meets EMC directives. For guidance on how to perform these EMC tests, please refer to "EMI testing of component power supplies." (as available on http://www.meanwell.com)</p>						

Mechanical Specification

Case No. 901 Unit:mm

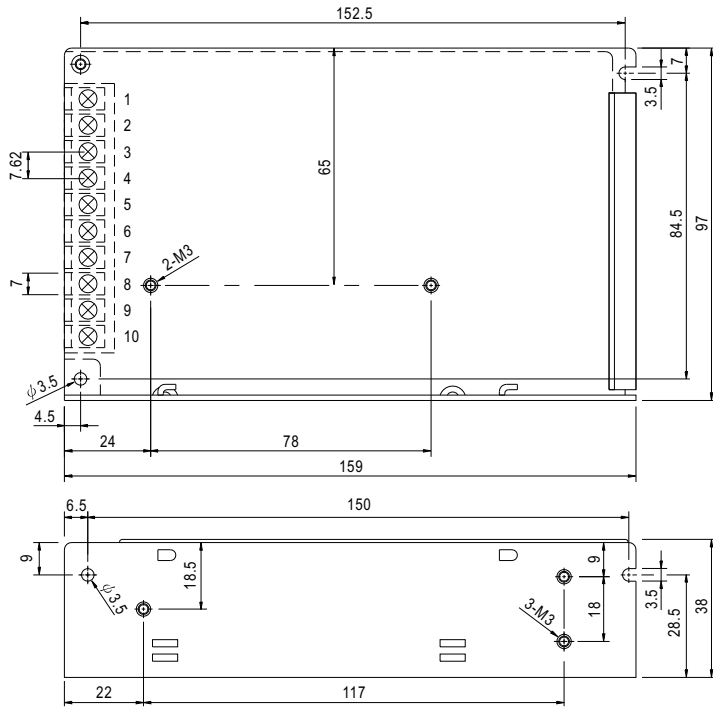

Terminal Pin No. Assignment

Pin No.	Assignment	Pin No.	Assignment
1	AC/L	6	DC OUTPUT +V2
2	AC/N	7	DC OUTPUT G3
3	FG \perp	8	DC OUTPUT +V3
4	NC	9	DC OUTPUT G1
5	DC OUTPUT G2	10	DC OUTPUT +5V

Block Diagram

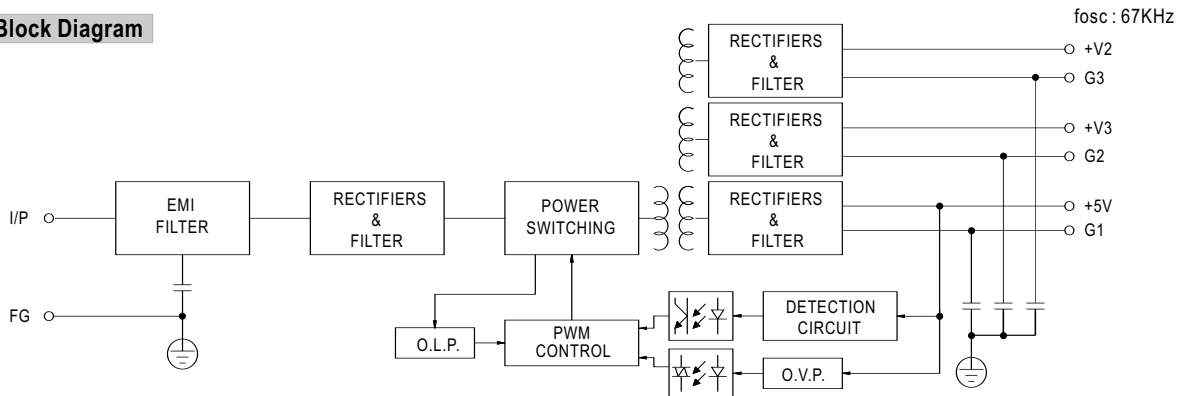

Derating Curve

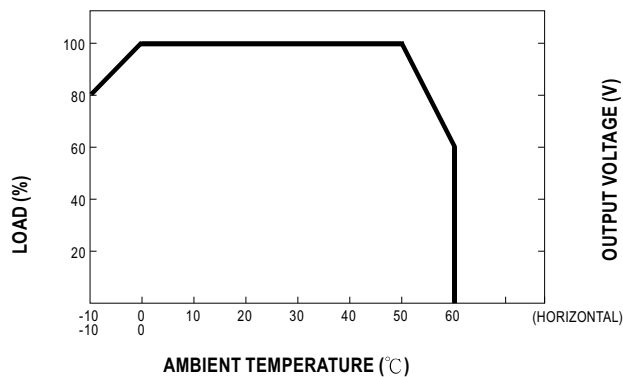

Static Characteristics

