



■ Features :

- Universal AC input/Full range
- ZVS new technology
- AC input active surge current limiting
- Built-in active PFC function,PF>0.95
- Protections: Short circuit / Overload / Over voltage / Over temperature
- Forced air cooling by built-in DC ball bearing fan
- High power density 8.3W/inch³
- Output voltage can be trimmed between 20% ~ 110% rated value
- Current sharing up to 4500W(2+1)
- Alarm signal output
- Built-in 12V/0.1A auxiliary output for remote control
- Built-in remote ON-OFF control
- Built-in remote sense function
- 3 years warranty



SPECIFICATION

MODEL	SPV-1500-12	SPV-1500-24	SPV-1500-48	
OUTPUT	DC VOLTAGE	12V	24V	48V
	RATED CURRENT	125A	63A	32A
	CURRENT RANGE	0 ~ 125A	0 ~ 63A	0 ~ 32A
	RATED POWER	1500W	1512W	1536W
	RIPPLE & NOISE (max.) Note.2	150mVp-p	150mVp-p	200mVp-p
	VOLTAGE ADJ. RANGE	±5% typical adjustment by VR, 20% ~ 110% (typ.) adjustment by 1~6VDC external control signal		
	VOLTAGE TOLERANCE Note.3	±1.0%		
	LINE REGULATION	±0.5%		
	LOAD REGULATION	±0.5%		
	SETUP, RISE TIME	1500ms, 100ms at full load		
HOLD UP TIME (Typ.)	10ms at full load	14ms at full load	16ms at full load	
INPUT	VOLTAGE RANGE Note.5	90 ~ 264VAC	127 ~ 370VDC	
	FREQUENCY RANGE	47 ~ 63Hz		
	POWER FACTOR (Typ.)	0.95/230VAC	0.98/115VAC at full load	
	EFFICIENCY (Typ.)	86.5%	90%	90%
	AC CURRENT (Typ.)	17A/115VAC	8A/230VAC	
	INRUSH CURRENT (Typ.)	30A/115VAC	60A/230VAC	
	LEAKAGE CURRENT	<2.0mA / 240VAC		
PROTECTION	OVERLOAD	105 ~ 135% rated output power Protection type : Constant current limiting, recovers automatically after fault condition is removed		
	OVER VOLTAGE	13.8 ~ 16.8V	30 ~ 34.8V	57.6 ~ 67.2V
	OVER TEMPERATURE	105°C ±5°C (TSW2) detect on heatsink of power transistor Protection type : Shut down o/p voltage, recovers automatically after temperature goes down		
FUNCTION	AUXILIARY POWER(AUX)	12V@0.1A(Only for Remote ON/OFF control)		
	REMOTE ON/OFF CONTROL	Please see the Function Manual		
	ALARM SIGNAL OUTPUT	Please see the Function Manual		
	OUTPUT VOLTAGE TRIM	2.4 ~ 13.2V	4.8 ~ 28V	9.6 ~ 56V
ENVIRONMENT	WORKING TEMP.	-20 ~ +70°C (Refer to output load derating curve)		
	WORKING HUMIDITY	20~90% RH non-condensing		
	STORAGE TEMP., HUMIDITY	-40 ~ +85°C, 10 ~ 95% RH		
	TEMP. COEFFICIENT	±0.05%/°C (0 ~ 50°C)		
	VIBRATION	10 ~ 500Hz, 2G 10min./1cycle, 60min. each along X, Y, Z axes		
SAFETY & EMC (Note 4)	SAFETY STANDARDS	UL60950-1, TUV EN60950-1 approved		
	WITHSTAND VOLTAGE	I/P-O/P:3KVAC I/P-FG:1.5KVAC O/P-FG:0.5KVAC		
	ISOLATION RESISTANCE	I/P-O/P, I/P-FG, O/P-FG:100M Ohms / 500VDC / 25°C / 70% RH		
	EMI CONDUCTION & RADIATION	Compliance to EN55022 (CISPR22)		
	HARMONIC CURRENT	Compliance to EN61000-3-2,-3		
	EMS IMMUNITY	Compliance to EN61000-4-2,3,4,5,6,8,11; ENV50204, EN55024, light industry level, criteria A		
OTHERS	MTBF	109K hrs min. MIL-HDBK-217F (25°C)		
	DIMENSION	278*127*83.5mm (L*W*H)		
	PACKING	3.0Kg; 4pcs/13Kg/1.19CUFT		
NOTE	<ol style="list-style-type: none"> 1. All parameters NOT specially mentioned are measured at 230VAC input, rated load and 25°C of ambient temperature. 2. Ripple & noise are measured at 20MHz of bandwidth by using a 12" twisted pair-wire terminated with a 0.1uf & 47uf parallel capacitor. 3. Tolerance : includes set up tolerance, line regulation and load regulation. 4. The power supply is considered a component which will be installed into a final equipment. The final equipment must be re-confirmed that it still meets EMC directives. For guidance on how to perform these EMC tests, please refer to "EMI testing of component power supplies." (as available on http://www.meanwell.com) 5. Derating may be needed under low input voltages. Please check the derating curve for more details. 			

Mechanical Specification

Case No.943A Unit:mm

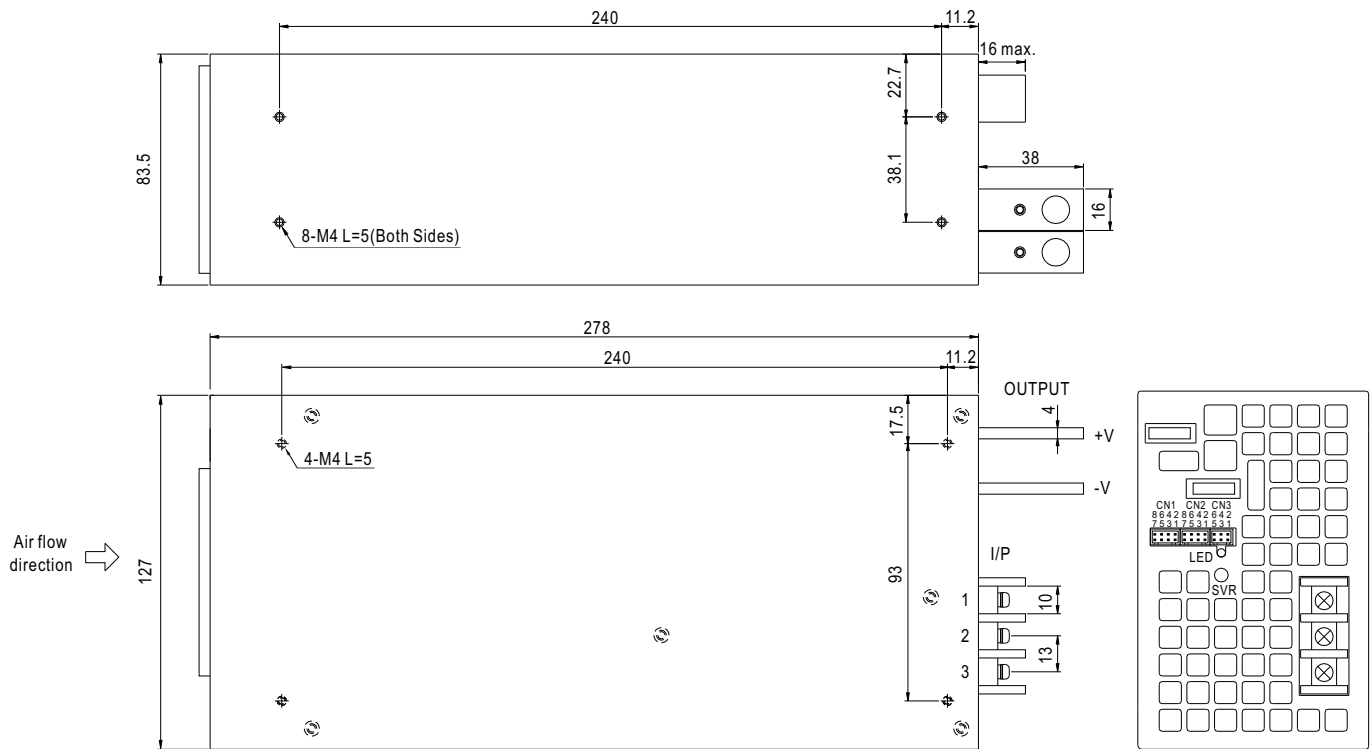

AC Input Terminal Pin No. Assignment

Pin No.	Assignment
1	FG \perp
2	AC/N
3	AC/L

Control Pin No. Assignment(CN1,CN2) : HRS DF11-8DP-2DS or equivalent

Pin No.	Assignment	Pin No.	Assignment	Mating Housing	Terminal
1	RCG	5,7	-S	HRS DF11-8DS or equivalent	HRS DF11-**SC or equivalent
2	RC2	6	LS(Current Share)		
3	PV	8	+S		
4	PS				

RCG: Remote ON/OFF Ground -S: -Remote Sensing
 RC2: Remote ON/OFF LS: Load Share
 PV: Output voltage external control +S: +Remote Sensing
 PS: Reference voltage terminal, PS and PV are connected when shipping

Control Pin No. Assignment(CN3) : HRS DF11-6DP-2DS or equivalent

Pin No.	Assignment	Pin No.	Assignment	Mating Housing	Terminal
1	P OK GND	4	AUXG	HRS DF11-6DS or equivalent	HRS DF11-**SC or equivalent
2	P OK	5	RC1		
3	RCG	6	AUX		

P OK GND: Power OK Ground AUXG: Auxiliary Ground
 P OK: Power OK Signal RC1: Remote ON/OFF
 RCG: Remote ON/OFF Ground AUX: Auxiliary Output

Block Diagram

PFC fosc : 70KHZ
 PWM fosc : 100KHZ

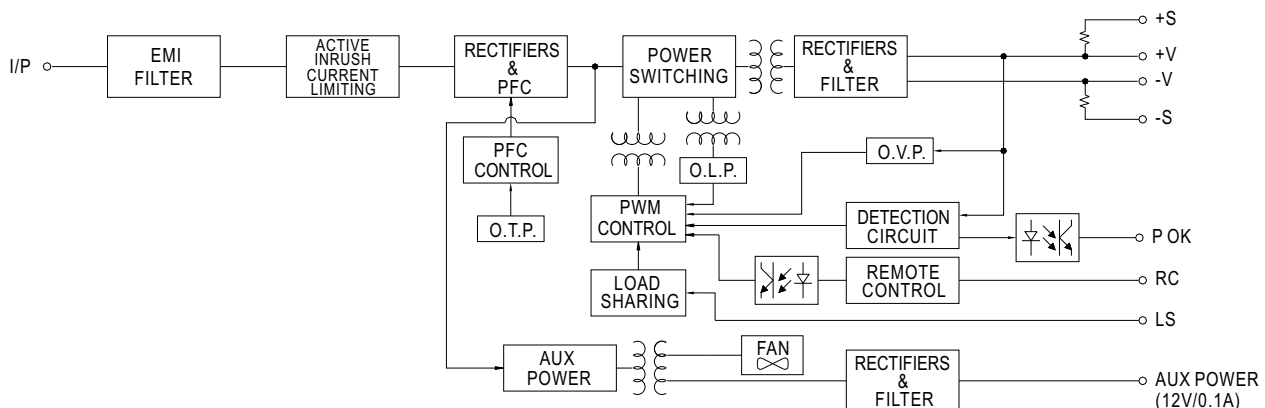

Derating Curve

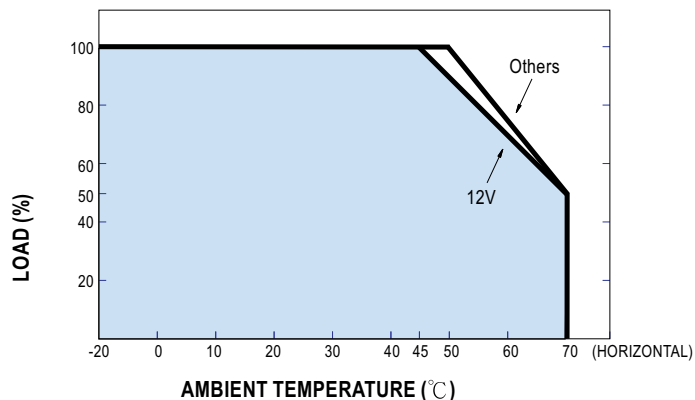

Static Characteristics

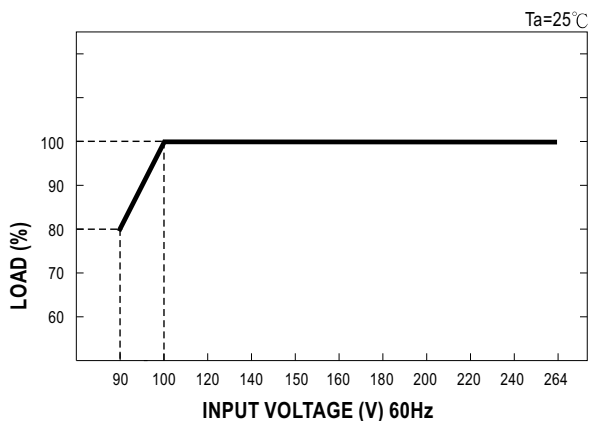

Function Manual

1.Remote ON/OFF

- (1) Remote ON/OFF control becomes available by applying voltage in CN1 & CN2 & CN3
- (2) Table 1.1 shows the specification of Remote ON/OFF function
- (3) Fig.1.2 shows the example to connect Remote ON/OFF control function

Table 1.1 Specification of Remote ON/OFF

Connection Method	Fig. 1.2(A)	Fig. 1.2(B)	Fig. 1.2(C)
SW Logic	Output on	SW Open	SW Close
	Output off	SW Close	SW Open

Fig.1.2 Examples of connecting remote ON/OFF

(A) Using external voltage source

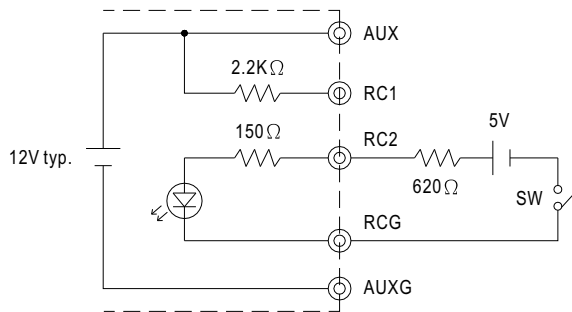

(B) Using internal 12V auxiliary output

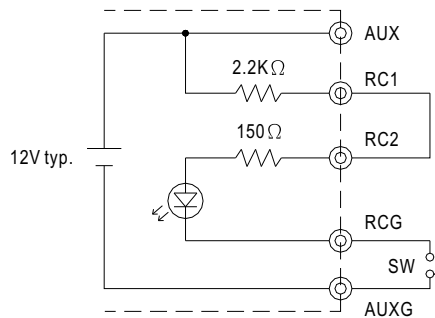

(C) Using internal 12V auxiliary output

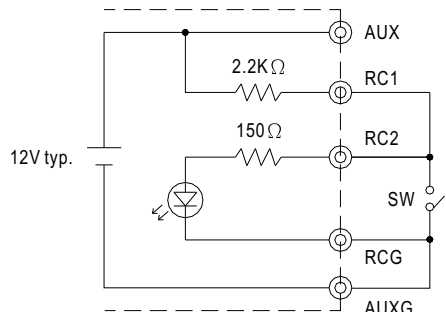

2. Alarm Signal Output

- (1) Alarm signal is sent out through "P OK" & "P OK GND" pins
- (2) An external voltage source is required for this function. The maximum applied voltage is 50V and the maximum sink current is 10mA
- (3) Table 2.1 explains the alarm function built-in the power supply

Function	Description	Output of alarm(P OK)
P OK	The signal is "Low" when the power supply is above 15% of the rated output voltage-Power OK	Low (0.5V max at 10mA)
	The signal turns to be "High" when the power supply is under 15% of the rated output voltage-Power Fail	High or open (External applied voltage 10mA max.)

Table 2.1 Explanation of alarm function

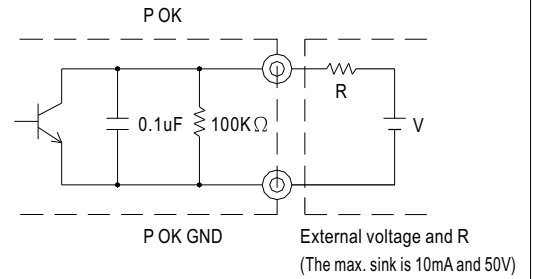
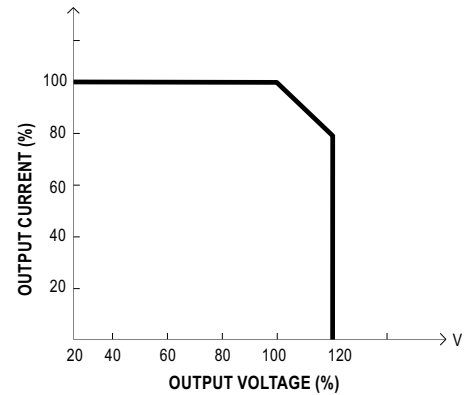
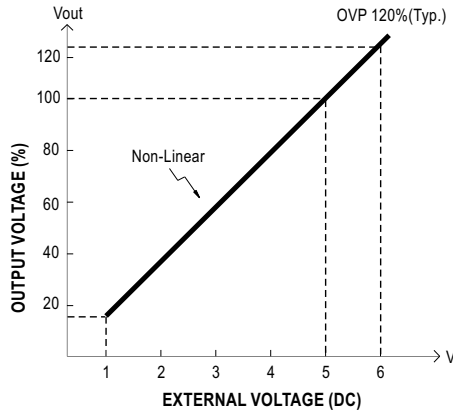
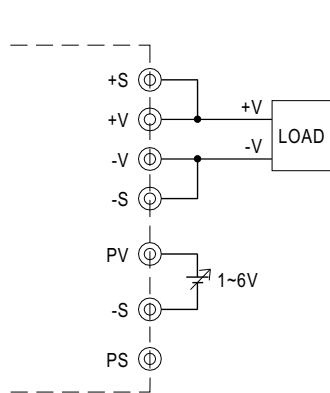

Fig. 2.2 Internal circuit of P OK (Open collector method)

3. External Voltage Control



Note: Reference voltage terminal, PS and PV are connected when shipping

4. Current Sharing

- (1) Parallel operation is available by connecting the units shown as below (+S,-S and LS are connected mutually in parallel):
 - (2) The voltage difference among each output should be minimized that less than ±2% is required
 - (3) The total output current must not exceed the value determined by the following equation (Output current at parallel operation)=(The rated current per unit) x (Number of unit) x 0.9
 - (4) In parallel operation 3 units is the maximum, please consult the manufacturer for other applications
 - (5) When remote sensing is used in parallel operation, the sensing wire must be connected only to the master unit
- Note : In parallel connection, maybe only one unit (master) operate if the total output load is less than 5% of rated load condition.
The other PSUs (slaves) may go into standby mode and their output LEDs will not turn on.

