

- Features :
- Universal AC input / Full range
  - Protections: Short circuit / Overload / Over voltage
  - Cooling by free air convection
  - With power good signal output(Optional)
  - 100% full load burn-in test
  - Fixed switching frequency at 45KHz
  - 2 years warranty

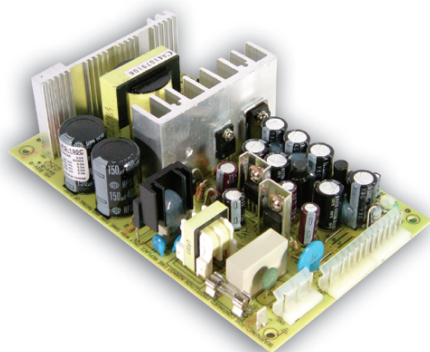

**SPECIFICATION**

MODEL		PQ-100B				PQ-100C				
OUTPUT	OUTPUT NUMBER	CH1	CH2	CH3	CH4	CH1	CH2	CH3	CH4	
	DC VOLTAGE	5V	12V	-5V	-12V	5V	15V	-5V	-15V	
	RATED CURRENT	10A	3.5A	0.5A	0.5A	8A	3.5A	0.5A	0.5A	
	CURRENT RANGE	2 ~ 10A	0.5 ~ 4.5A	0 ~ 1A	0 ~ 1A	2 ~ 8A	0.5 ~ 4A	0 ~ 1A	0 ~ 1A	
	RATED POWER	100.5W				102.5W				
	RIPPLE & NOISE (max.) Note.2	80mVp-p	250mVp-p	80mVp-p	120mVp-p	80mVp-p	150mVp-p	80mVp-p	150mVp-p	
	VOLTAGE ADJ. RANGE	CH1:4.75 ~ 5.5V				CH1:4.75 ~ 5.5V				
	VOLTAGE TOLERANCE Note.3	±3.0%	±12%	±6.0%	±6.0%	±2.0%	±6.0%	±6.0%	±6.0%	
	LINE REGULATION	±1.0%	±5.0%	±1.0%	±1.0%	±1.0%	±3.0%	±1.0%	±1.0%	
	LOAD REGULATION	±2.0%	±5.0%	±1.0%	±1.0%	±1.0%	±5.0%	±1.0%	±1.0%	
SETUP, RISE TIME	1200ms, 50ms at full load									
HOLD UP TIME (Typ.)	80ms at full load									
INPUT	VOLTAGE RANGE	100 ~ 264VAC 141 ~ 370VDC (90 ~ 100VAC 90% load max.)								
	FREQUENCY RANGE	47 ~ 63Hz								
	EFFICIENCY(Typ.)	72%				74%				
	AC CURRENT (Typ.)	3A/115VAC		1.5A/230VAC						
	INRUSH CURRENT (Typ.)	COLD START 50A								
	LEAKAGE CURRENT	<1mA /240VAC								
PROTECTION	OVERLOAD	105% ~ 135% rated output power Protection type : Hiccup mode, recovers automatically after fault condition is removed								
	OVER VOLTAGE	CH1: 5.75 ~ 6.75VDC Protection type : Hiccup mode, recovers automatically after fault condition is removed								
FUNCTION	POWER GOOD	≥1ms								
ENVIRONMENT	WORKING TEMP.	-10 ~ +50°C, 60 °C with cooling fan(Refer to output load derating curve)								
	WORKING HUMIDITY	20 ~ 90% RH non-condensing								
	STORAGE TEMP., HUMIDITY	-20 ~ +85°C, 10 ~ 95% RH								
	TEMP. COEFFICIENT	±0.03%/°C (0 ~ 50°C)								
	VIBRATION	10 ~ 500Hz, 2G 10min./1cycle, period for 60min. each along X, Y, Z axes								
SAFETY & EMC (Note 4)	SAFETY STANDARDS	UL60950-1, TUV EN60950-1 approved								
	WITHSTAND VOLTAGE	I/P-O/P:3KVAC I/P-FG:1.5KVAC O/P-FG:0.5KVAC								
	ISOLATION RESISTANCE	I/P-O/P, I/P-FG, O/P-FG:100M Ohms / 500VDC / 25°C / 70% RH								
	EMI CONDUCTION & RADIATION	Compliance to EN55022 (CISPR22) Class B								
	HARMONIC CURRENT	Compliance to EN61000-3-2,-3								
	EMS IMMUNITY	Compliance to EN61000-4-2,3,4,5,6,11; ENV50204, light industry level, criteria A								
OTHERS	MTBF	258.6K hrs min. MIL-HDBK-217F (25°C)								
	DIMENSION	177.8*107.95*46mm (L*W*H)								
	PACKING	0.56Kg; 24pcs/14.5Kg/1.19CUFT								
NOTE	<p>1. All parameters NOT specially mentioned are measured at 230VAC input, rated load and 25°C of ambient temperature.</p> <p>2. Ripple &amp; noise are measured at 20MHz of bandwidth by using a 12" twisted pair-wire terminated with a 0.1uf &amp; 47uf parallel capacitor.</p> <p>3. Tolerance : includes set up tolerance, line regulation and load regulation.</p> <p>4. The power supply is considered a component which will be installed into a final equipment. The final equipment must be re-confirmed that it still meets EMC directives. For guidance on how to perform these EMC tests, please refer to "EMI testing of component power supplies." (as available on <a href="http://www.meanwell.com">http://www.meanwell.com</a>)</p>									



■ Features :

- Universal AC input / Full range
- Protections: Short circuit/Over load/Over voltage
- Cooling by free air convection
- With power good signal output(Optional)
- 100% full load burn-in test
- Fixed switching frequency at 45KHz
- 2 years warranty



SPECIFICATION

MODEL		PQ-100D				PQ-100E			
OUTPUT	OUTPUT NUMBER	CH1	CH2	CH3	CH4	CH1	CH2	CH3	CH4
	DC VOLTAGE	5V	12V	24V	-12V	5V	12V	15V	24V
	RATED CURRENT	5A	2A	2A	0.5A	8A	3A	0.6A	0.6A
	CURRENT RANGE	2 ~ 5A	0.5 ~ 4.5A	0.4 ~ 2A	0 ~ 1A	2 ~ 8A	0.5 ~ 3A	0 ~ 1A	0 ~ 1A
	RATED POWER	103W				99.4W			
	RIPPLE & NOISE (max.) Note.2	80mVp-p	120mVp-p	180mVp-p	120mVp-p	80mVp-p	120mVp-p	150mVp-p	120mVp-p
	VOLTAGE ADJ. RANGE	CH1:4.75 ~ 5.5V				CH1:4.75 ~ 5.5V			
	VOLTAGE TOLERANCE Note.3	±2.0%	±6.0%	±10%	±6.0%	±2.0%	±6.0%	±6.0%	±6.0%
	LINE REGULATION	±1.0%	±3.0%	±1.0%	±1.0%	±1.0%	±3.0%	±1.0%	±1.0%
	LOAD REGULATION	±1.0%	±5.0%	±5.0%	±1.0%	±1.0%	±5.0%	±1.0%	±1.0%
SETUP, RISE TIME	1200ms, 50ms at full load								
HOLD TIME (Typ.)	80ms at full load								
INPUT	VOLTAGE RANGE	100 ~ 264VAC 141 ~ 370VDC (90 ~ 100VAC 90% load max.)							
	FREQUENCY RANGE	47 ~ 63Hz							
	EFFICIENCY (Typ.)	77%				74%			
	AC CURRENT (Typ.)	3A/115VAC 1.5A/230VAC							
	INRUSH CURRENT (Typ.)	COLD START 50A							
	LEAKAGE CURRENT	<1mA /240VAC							
PROTECTION	OVER LOAD	105% ~ 135% rated output power Protection type : Hiccup mode, recovers automatically after fault condition is removed							
	OVER VOLTAGE	CH1: 5.75 ~ 6.75VDC Protection type : Hiccup mode, recovers automatically after fault condition is removed							
FUNCTION	POWER GOOD	≥ 1ms							
ENVIRONMENT	WORKING TEMP.	-10 ~ +50°C, 60 °C with cooling fan(Refer to output load derating curve)							
	WORKING HUMIDITY	20 ~ 90% RH non-condensing							
	STORAGE TEMP., HUMIDITY	-20 ~ +85°C, 10 ~ 95% RH							
	TEMP. COEFFICIENT	±0.03%/°C (0 ~ 50°C)							
	VIBRATION	10 ~ 500Hz, 2G 10min./1cycle, period for 60min. each along X, Y, Z axes							
SAFETY & EMC (Note 4)	SAFETY STANDARDS	UL60950-1, TUV EN60950-1 approved							
	WITHSTAND VOLTAGE	I/P-O/P:3KVAC I/P-FG:1.5KVAC O/P-FG:0.5KVAC							
	ISOLATION RESISTANCE	I/P-O/P, I/P-FG, O/P-FG:100M Ohms / 500VDC / 25°C / 70% RH							
	EMI CONDUCTION & RADIATION	Compliance to EN55022 (CISPR22) Class B							
	HARMONIC CURRENT	Compliance to EN61000-3-2,-3							
OTHERS	EMS IMMUNITY	Compliance to EN61000-4-2,3,4,5,6,11; ENV50204, light industry level, criteria A							
	MTBF	258.6K hrs min. MIL-HDBK-217F (25°C)							
	DIMENSION	177.8*107.95*46mm (L*W*H)							
NOTE	PACKING	0.56Kg; 24pcs/14.5Kg/1.19CUFT							
		1. All parameters NOT specially mentioned are measured at 230VAC input, rated load and 25°C of ambient temperature. 2. Ripple & noise are measured at 20MHz of bandwidth by using a 12" twisted pair-wire terminated with a 0.1uf & 47uf parallel capacitor. 3. Tolerance : includes set up tolerance, line regulation and load regulation. 4. The power supply is considered a component which will be installed into a final equipment. The final equipment must be re-confirmed that it still meets EMC directives. For guidance on how to perform these EMC tests, please refer to "EMI testing of component power supplies." (as available on <a href="http://www.meanwell.com">http://www.meanwell.com</a> )							

**Mechanical Specification**

Unit:mm

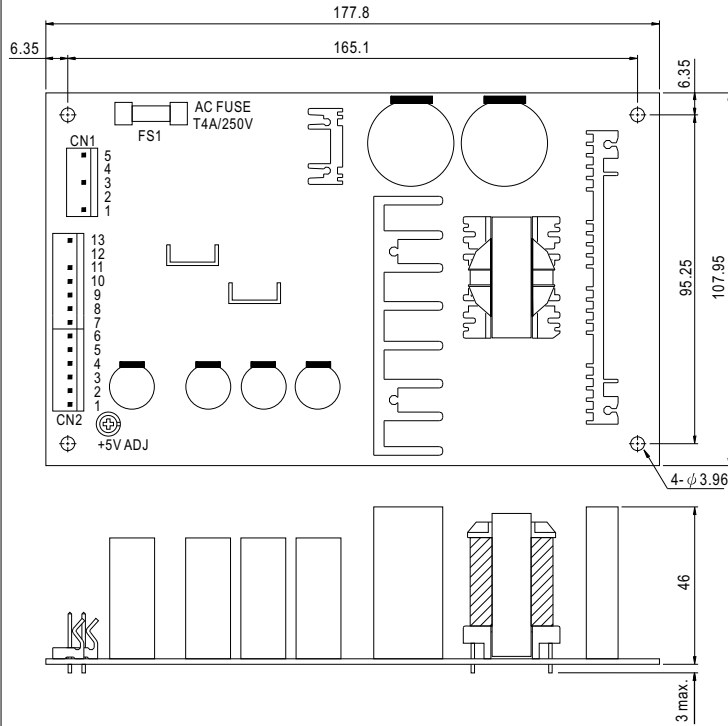

AC Input Connector (CN1) : Molex 5273-05 or equivalent

Pin No.	Assignment	Mating Housing	Terminal
1	FG $\perp$	Molex 5195 or equivalent	Molex 5194 or equivalent
2,4	No Pin		
3	AC/N		
5	AC/L		

DC Output Connector (CN2) : Molex 5273-06,07 or equivalent

Pin No.	Assignment	Mating Housing	Terminal
1,2,3	V1	Molex 5195 or equivalent	Molex 5194 or equivalent
4,5,6,7	COM		
8,9	V2		
10	Power Good(Optional)		
11	V3	Molex 5195 or equivalent	Molex 5194 or equivalent
12	No Pin		
13	V4		

fosc : 45KHz

**Block Diagram**

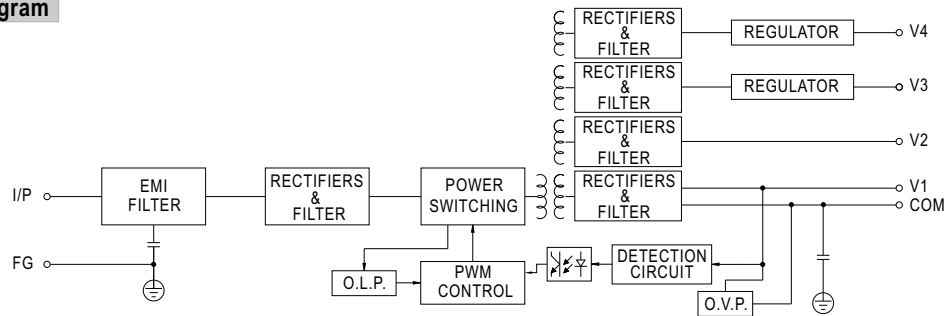

**Derating Curve**

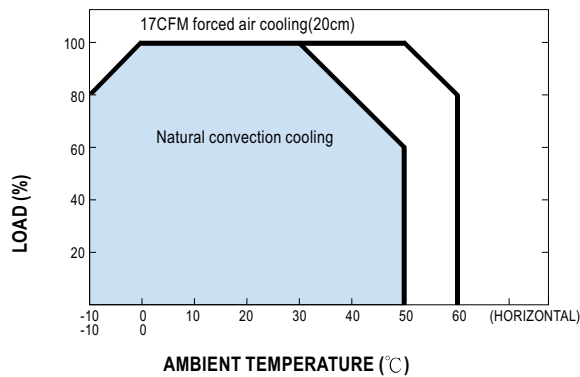

**Static Characteristics (B)**

