

Compact Power Line

48V DC Critical Power Solution

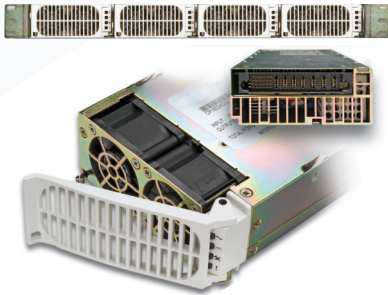

1RU CPL Power System

- Compact 48V DC distributed power system
- Efficiency approaching 97%
- Maximum power in minimal space
- Scalable to 80 kW
- Powering enterprise and telecommunications networks

Overview

The Compact Power Line platform is designed to provide highly reliable DC power for 48V distributed power architectures. A single shelf configuration provides up to 11kW of 48V output power in 1U high and mounts in 19-inch or 23-inch wide frames. The CPL product platform is easily expandable for future growth. CPL is a reliable DC power solution for mission-critical enterprise and telecommunications network equipment.

Shelf Options

The CP product line provides several shelf options with common or split DC output configurations. J85480S1 shelves have four slots for rectifiers or converters (PEMs). CPL shelves are primarily used without a controller or with a customer's controller using I2C communications. J2007001 shelves have four slots with space for a full-feature Pulsar Edge Controller. The Pulsar Edge controller has Ethernet connectivity to facilitate remote network management to monitor and control rectifiers, batteries, and distribution. CPL is ideal for a broad range of applications requiring highly efficient 48V DC power.

Rectifier Options

CP2000 and CP2725 rectifiers are single phase, constant power rectifiers that provide 2000 Watts and 2725 Watts (respectively) of highly reliable DC power. The constant output power characteristics, extended temperature range, universal AC input, and compact size are key attributes that make this rectifier the right choice for your power needs.

Pulsar Edge Controller

CPL features the Pulsar Edge controller delivering large system intelligence in a small system form factor. Ethernet connectivity with SNMP facilitates remote network management.

Benefits

Reliability

- Proven field performance
- Advanced alarming
- N+1 modularity

Intelligence

- Industry leading controller features
- Ethernet interface for remote access
- Centralized network management

Investment Protection

- Minimal space requirements
- Versatile configurations
- Efficient operation

On Time Delivery

- Standard building blocks
- 4 - 6 week availability
- 24/7 support

Total Efficiency

The Lineage Power Total Efficiency™ (TE) architecture reduces energy loss and lowers cooling costs by 50-70%. TE products will prioritize sustainable energy sources like solar, wind, water and fuel cells over traditional utility grid or diesel generator sources – and they will intelligently respond to smart grid information to reduce consumption during peak demand periods. Active Rectifier Management (ARM) and Battery Charging Optimization (BCO) features increase efficiency on current and legacy power infrastructures. The Total Efficiency architecture addresses issues end-to-end based on our proven experience and expertise in batteries, power distribution, DC energy systems, AC-DC power supplies, and DC-DC board mounted power to deliver a solution that is more safe, reliable and energy efficient than alternatives from our competitors.

CP2725 Total Efficiency™ Rectifier



The CP2725 TE high efficiency rectifier provides significantly improved operational efficiency and is fully backwards compatible with currently deployed CPL energy systems. This high-density front-to-back airflow rectifier is designed for minimal space utilization and is highly expandable for future growth.

The power module is available with many features including PoE isolation, RS485 communications bus for use with Lineage Power battery-plant controllers in forming an energy reserve system and redundant I²C communications bus for use with a customer's controller. This flexible and sophisticated feature set makes this front-end power supply an excellent choice for power in a variety of application spaces.

Applications

- Enterprise networks
- Telecom equipment
- Power over Ethernet
- VoIP/soft switches
- SAN/NAS/iSCSI applications
- LAN/WAN/MAN applications
- Indoor wireless
- Routers and switches

Key Features

- Compact 1RU form factor
- PMBus compliant dual I²C and RS485 serial bus communications
- Front panel LED indicators
- Internal variable-speed fan control
- Constant power; 52 – 58 Vdc
- Programmable output voltage; 44 – 58 Vdc
- Universal AC input
- PoE compliant
- CE marked
- RoHS 6 compliant
- Hot pluggable

Specifications

Input	
Voltage Range - Low-Line - High-Line	90 - 175 Vac (1200W) 175 - 300 Vac (2725)
Input Frequency	45 – 66 Hz
Input Current	11.2 Amps @ 110Vac 14.2 Amps @ 240Vac
Inrush Transient	25 Apk max Measured at 25°C for all line conditions; does not include X-capacitors charging.
Input Leakage Current	2.5 mA typical 3.5 mA max Measured at 265Vac, 60Hz
Total Harmonic Distortion (THD)	< 5%
Power Factor	0.98 typical from 50% TO 100% load
Holdup Time	15 ms @ 75% full power 20 ms (loads below 1200W)
Power Fail Warning	5 ms, Alarm issued via PFW signal going LO 5 ms prior to the main output decaying below 40Vdc.
EMC Conducted	FCC and CISPR22 (EN55022) Class A

Output	
Voltage Default	54 Vdc
Voltage Adjust Range - Hardware set via margin pin - I ² C or RS485 set	44 – 58 Vdc 42 – 58 Vdc
Output Current - Low-Line - High-Line	22.2 Adc, 54V 50.5 Adc, 54V 52.4 Adc, 52V 37 Adc, 54V at 2000W 38.4 Adc, 52V at 2000W
Output Power - Low-Line - High-Line	1200 Watts 2725 Watts 2000 Watts at nominal 277Vac and Tamb > 45°C
Psophometric Noise	4 mVrms max
Ripple (5Hz to 20MHz) - RMS - Peak-to-Peak	250 mVrms 500 mVpk-pk
Overvoltage Protection - Delayed - Immediate	60 Vdc (200 ms delayed shutdown) 65 Vdc (Instantaneous shutdown above this point.)
Over Temperature - Warning - Shutdown - Auto-recoverable	5°C 20°C Temperature hysteresis of approximately 10°C provided between shutdown and restart.
Overload Current Limit - Low Line	26 Adc Fold_down current limit
Overload Current Limit < 41.5Vo - High Line	36 Adc Fold_down current limit
Overload Current Limit > 41.5Vo - High Line	53-58 Adc Fold_down current limit (FL = 52.4A @ 52V) Hiccup mode with a 10% duty cycle enabled below 39Vdc. Latched mode current limit optional. Above 275V input the voltage level at which current limit changes states is 45V. There is a 30 second delay prior to shifting to the lower limit.
Overload System Power Up	Units should be able to be plugged in one at a time and guarantee system start up. Units should stay in current limit for approximately 20 seconds to guarantee restart.
Overall Regulation	-2% to +2% includes all variations due to specified load range, drift, and environmental conditions.
Current Share	-5%FL to +5%FL compared to the average output current delivered by a set of rectifiers. Loads > 50% FL
Proportional Current Share	<7%FL among rectifiers of different output capacities
External Bulk Load Capacitance	5,000µF max External capacitance can be increased but the power supply will not meet its turn-ON rise time requirement
Turn-ON Delay	5 seconds Monotonic Turn_ON from 30% to 100% of Vnom above -5°C operation. Monotonic Turn_On from 60% to 100% of Vnom below -5°C operation.
Turn-ON Rise Time	100 ms standard (PMBus) 5 s telecom (RS-485)
Turn-ON Overshoot	2%
Load Step Response	$\Delta I/\Delta t$ slew rate 1A/µs
Load Step Response ΔI	50%FL Settling time to within regulation requirements
Load Step Response ΔV	2.0Vdc Minimum load of 2.5A required
Load Step Response Time	2 ms

Auxiliary Output	
Output Voltage Setpoint	5 Vdc
Output Current	0.005A min 0.75A max
Overall Regulation	-10% to +5% within $\pm 5\%$ when load is < 0.5A.
Ripple and Noise	50 mVpk-pk typical 100 mVpk-pk max 20 Mhz bandwidth
Over-voltage Clamp	7 Vdc
Over-current Limit	110 %FL min 175 %FL max

General	
Cooling	Internal variable-speed fan cooled
Efficiency	Approaching 97%
Heat Dissipation	114 W / 387 BTU

Mechanical	
Length (in./mm)	13.85 / 351.8
Width (in./mm)	4 / 101.6
Height (in./mm)	1.63 / 41.4
Weight (lb / kg)	5 / 2.27

Environmental	
Operating Temperature	-40°C1 to +75°C (-40 to 167 °F) 2°C max ambient derating per 1,000 ft elevation above 5,000 ft. 2% per °C power derating above 55°C.
Storage Temperature	-40°C to +85°C (-40 to 185 °F)
Power De-Rating	> +55°C (derates @ 2% per ° C)
Relative Humidity	95% max, non-condensing
Altitude	4,000m max (13,000 ft)
Audible Noise	55dBA, typical Noise proportional to fan speed, load and ambient temperature.

1. Designed to start at an ambient as low as -40°C but may not meet operational limits until above -5°C.

Safety and Standards Compliance	
Earthquake Zone 4	Per Telcordia GR-63-CORE, all floors when installed in CPL shelf
Shock and Vibration	IPC9592 Sections 5.2.8-5.2.13
Harmonic Emissions	Per EN/IEC61000-3-2
Conducted Emissions	Exceeds FCC and CISPR22 (EN55022) Class A Telcordia GR-1089-CORE - Class A by a 6dB margin
Conducted Immunity	Error free per EN/IEC 61000-4-6 Level 3 (10Vrms).
Radiated Immunity	Electrical Fast Transient Burst
Electrical Fast Transient Burst	EN/IEC 61000-4-4 Level 3 (2 kV, 5 kHz repetition rate)
Lightning Surge (Error Free)	EN/IEC61000-4-5 Level 4 (4 kV common mode, 2 kV differential mode).
Lightning Surge (Damage Free)	ANSI C62.41 Level A3 (6 kV common and differential mode)
Isolation Input - Chassis/Signals	1500 Vrms per EN60950
Isolation Input - Output	3000 Vrms (Consult factory)
Isolation Output - Chassis	500 Vdc per Lineage standard GR_947
Reliability	900,000 hour MTBF (calculated) at 25°C ambient at full load per Telcordia SR-332, issue 2, Reliability Prediction for Electronic Equipment, Method I Case III
Service Life	10 years at 25°C ambient, full load excluding fans
Safety	CE mark to Low Voltage Directive 2006/95/EC UL 60950-1 Recognized CAN/CSA C22.2 No. 60950-1-03 Certified VDE 0805-1 Licensed to IEC60950-1
RoHS	Compliant to RoHS EU Directive 2002/95/EC
EMC	FCC and CISPR22 (EN 55022) Class A (6dB margin) Radiated emissions compliance was met using a Lineage Power shelf. This shelf includes output common and differential mode capacitors that assist in meeting compliance.
ESD	EN/IEC 61000-4-2 Level 4 (8 kV contact discharge, 15 kV air discharge).

* UL is a registered trademark of Underwriters Laboratories, Inc.











† CSA is a registered trademark of Canadian Standards Association.

‡ VDE is a trademark of Verband Deutscher Elektrotechniker e.V.

§ This product is intended for integration into end-user equipment. All the required procedures for CE marking of end-user equipment should be followed. (The CE mark is placed on selected products.)

** ISO is a registered trademark of the International Organization of Standards.

Front Panel LEDs

Symbol	Analog Mode	I ² C Mode	RS485 Mode
		On: Input OK Blinking: Input out of limits	
		On: Output OK Blinking: Overload	
	On: Over-temperature warning	On: Over-temperature warning Blinking: Service	On: Over-temperature warning
	 On: Fault		On: Output OK Blinking: Overload

Dimensions

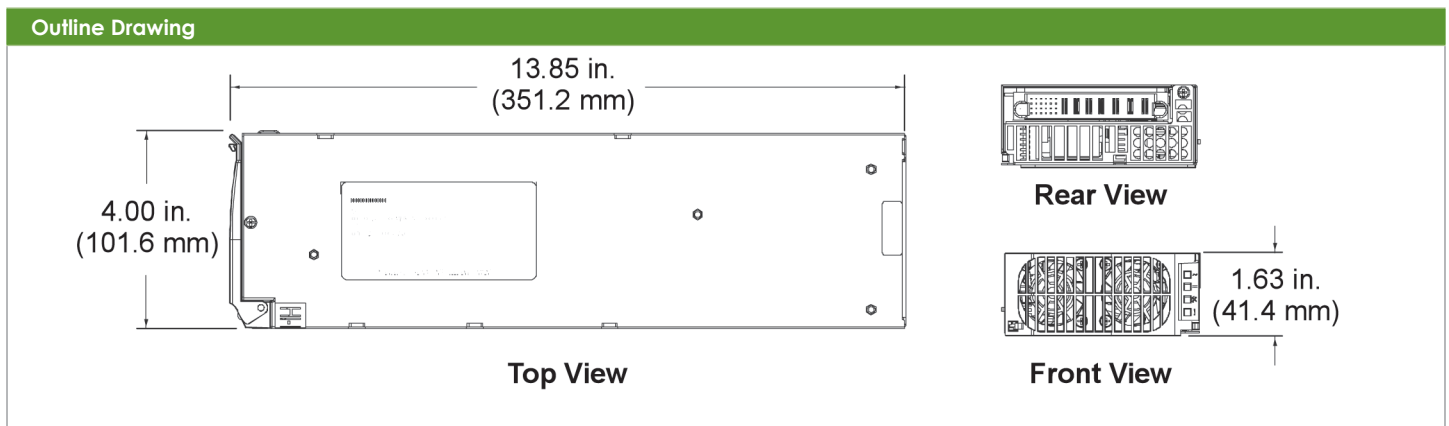

Status and Control

The rectifier provides three means for monitor/control: Analog, PMBus compliant I2C, or RS485 for interfacing to Lineage Power controllers or battery plants.

Details of analog controls are provided in this data sheet under Signal Definitions. Lineage Power will provide separate application notes on the PMBus compliant I2C or the RS485 protocol. Contact your local Lineage Power representative for details.

Hot Plug

When rapidly extracting and reinserting modules care should be taken to allow for discharging the internal bias supply so that a predictable restart could be achieved. To ensure that the circuit sufficiently discharges, observe the spinning of the fan after an extraction. The unit should not be reinserted until the fan stop spinning.

Control Definitions

All signals are referenced to Logic GRD unless otherwise noted. See the Signal Definitions Table at the end of this document for further description of all the signals.

Input Signals

Margining: Set point of the rectifier can be changed via this input pin. Programming can be either a voltage source or a resistance divider. The margining pin is connected to 3.3Vdc via a 10kΩ resistor inside the rectifier. See graphs below.

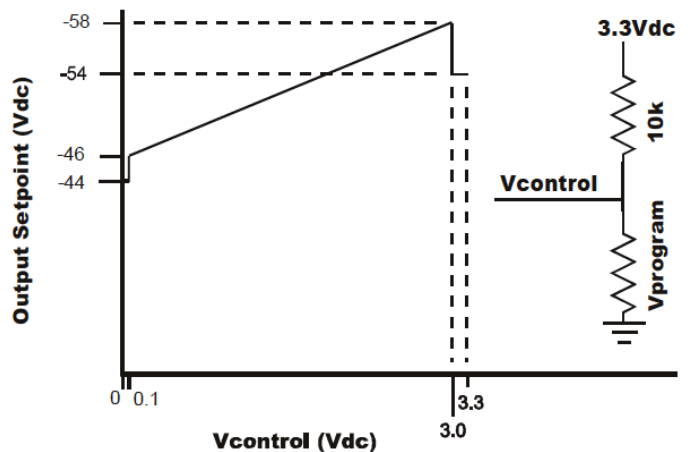

An open circuit on this pin reverts the voltage level back to the factory default setting.

Module Present Signal: This signal has dual functionality. It can be used to alert the system when a module is inserted. A 500Ω resistor is present in series between this signal and Logic_GRD. An external pull-up should not raise the voltage on the pin above 0.25Vdc. Above 1Vdc, the write_protect feature of the EEPROM is enabled.

Protocol Select: Establishes the communications mode of the power supply. No connect for analog/I2C. For RS485, connect 10kΩ pull-down resistor to 54_OUT(-DC).

Enable: On/Off control when PMBus communications are utilized as configured by the Protocol pin. This pin must be pulled low to turn ON the power supply. The power supply will turn OFF if either the Enable or the ON/OFF pin is released. The Enable function does not exist for the RS485 protocol. This signal is referenced to Logic_GRD.

ON/OFF: This is a short pin utilized for hot-plug applications to ensure that the power supply turns OFF before the power pins are disengaged. It also ensures that the power supply turns ON only after the power pins have been engaged. Must be connected to Vout (-).

Output Signals

Alert #: PMBus interrupt signal.

Fault: This signal goes LO for any failure that requires rectifier replacement. Some of these faults may be due to:

- Fan failure
- Over-temperature condition
- Over-temperature shutdown
- Over-voltage shutdown
- Internal Rectifier Fault

Power Capacity: A HI on this pin indicates that the rectifier delivers high power (2725W @ ≤240V, 2000W @ 277V) operation; a LO indicates rectifier configured for 1200W operation.

Alarm Table

Condition	Power Supply LED State				Monitoring Signals (Referenced to Logic_GRD)				
	AC OK Green	DC OK Green	Service Amber	Fault Red	Fault	OTW	PFW	Module Present	
OK	1	1	0	0	HI	HI	HI	LO	
Thermal Alarm (5C before shutdown)	1	1	1	0	HI	LO	HI	LO	
Thermal Shutdown	1	0	1	1	LO	LO	LO	LO	
Defective Fan	1	0	0	1	LO	HI	LO	LO	
Blown AC Fuse in Unit	1	0	0	1	LO	HI	LO	LO	
No AC <15mS (single unit)	0	1	0	0	HI	HI	LO ³	LO	
AC Present but not within limits	Blinks	0	0	0	HI	HI	LO	LO	
AC not present ¹	0	0	0	0	HI	HI	LO	LO	
Boost Stage Failure	1	0	0	1	LO	HI	LO	LO	
Over Voltage Latched Shutdown	1	0	0	1	LO	HI	LO	LO	
Over Current	1	Blinks	0	0	HI	HI	LO	LO	
Non-catastrophic Internal Failure ²	1	1	0	1	LO	HI	HI	LO	
1 Missing Module								HI ⁴	
Standby (remote)	1	0	0	0	HI	HI	LO	LO	
Service Request (PMBus mode)	1	1	Blinks	0	HI	HI	HI	LO	
Communications Fault (RS485 mode)	1	1	0	Blinks	HI	HI	HI	LO	

¹ This signal is correct if the rectifier is back biased from other rectifiers in the shelf .

² Any detectable fault condition that does not result in the power supply shutting down. For example, ORing FET failure, boost section out of regulation, etc.

³ Signal transition from HI to LO is output load dependent

⁴ Signal must be pulled HI external to the module



Output Connector

Mating Connector: AMP 1450572-1

Signal Pins							Power Output				Power Input		
	6	5	4	3	2	1	P7	P8	P6	P4	P3	P2	P1
A	SCL_0	MOD_PRES	PFW	LOGIC_GRD	RS_485+	UNIT_ADDR							
B	SCL_1	OTW	Alert#_0	Alert#_1	RS_485-	8V_INT	V_OUT	V_OUT	V_OUT	V_OUT	EARTH	LINE-2	LINE-1
C	SDA_0	Margin	Enable	Reset	Ishare	Protocol	(-)	(+)	(+)	(-)	(GND)	(Neutral)	(HOT)
D	SDA_1	Fault	5VA	Power_Cap	ON/OFF	SHELF_ADDR							

Note: Connector is viewed from the rear positioned inside the rectifier

Signal pins columns 1 and 2 are referenced to V_OUT (-)

Signal pins columns 3 through 6 are referenced to Logic GRD

■ Last to make-first to break shortest pin

■ First make-last to break longest pin implemented in the mating connector

Signal Definitions

All hardware alarm signals (Fault, PFW, OTW, Power Capacity) are open drain FETs. These signals should be pulled HI to either 3.3V or 5V. Maximum sink current 5mA. An active LO signal (< 0.4Vdc) state. All signals are referenced to Logic GRD unless otherwise stated. Contact your Lineage Power representative for more details.

Function	Label	Type	Description
Output Enable	Enable	Input	If shorted to LOGIC_GRD, the rectifier output is enabled when using I ² C mode of operation. May also be toggled to reset a latched OFF rectifier. Function not available in RS485 mode.
Power Fail Warning	PFW	Output	An open drain FET; normally HI, indicating output power is present. Changes to LO at least 5msec before the output voltage decays below 40Vdc.
I ² C Interrupt	Alert#_0 Alert#_1	Output	Interrupt signal via I ² C lines indicating that service is requested from the host controller. This signal pin is pulled up to 3.3V via a 10kΩ resistor and switches to active LO when an interrupt occurs.
Rectifier Fault	Fault	Output	Indicates that an internal fault exists. An open drain FET; normally HI, changes to LO.
Module Present	MOD_PRES	Output	Short pin, see Status and Control description for further information on this signal.
ON/OFF	ON/OFF	Input	Short pin, connects last and breaks first; used to activate and deactivate output during hot-insertion and extraction, respectively. Ref: Vout (-)
Protocol select	Protocol	Input	See Status and Control description for further information on this signal. Ref: Vout (-).
Margining	Margin	Input	Allows changing of output voltage through an analog voltage input or via resistor divider.
Over-Temperature Warning	OTW	Output	An open drain FET; normally HI, changes to LO approximately 5°C prior to thermal shutdown.
Power Capacity	POWER_CAP	Output	Open drain FET; Used to indicate rectifier operation mode; HI indicates 2725W operation and LO indicates 1200W operation.
Rectifier address	Unit_addr	Input	Voltage level addressing of rectifiers within a single shelf. Ref: Vout (-).
Shelf Address	Shelf_addr	Input	Voltage level addressing of rectifiers within multiple shelves. Ref: Vout (-).
Back bias	8V_INT	Bi-direct	Diode OR'ed 8Vdc drain; used to back bias microprocessors and DSP of failed rectifier from operating rectifiers. Ref: Vout (-).
Mux Reset	Reset	Input	Resets the I ² C lines to I ² C line 0.
Standby power	5VA	Output	5V at 0.75A provided for external use by either adjacent power supplies or the using system.
Current Share	Ishare	Bi-direct	A single wire interface between each of the power unit forces them to share the load current. Ref: Vout (-).
I ² C Line 0	SCL_0, SDA_0	Input	I ² C line 0.
I ² C Line 1	SCL_1, SDA_1	Input	I ² C line 1.
I ² C Interrupt	Alert#	Output	Goes active LO
RS485 Line	RS_485+ RS_485-	Bi-direct	RS485 line.

CPL 2000 Rectifiers



The CPL 2000 rectifiers are specifically designed to operate as an integral part of a complete distributed power system. The high-density, front-to-back airflow rectifier is designed for minimal space utilization and is highly expandable for future growth.

The power modules are available with many features including PoE isolation, RS485 communications bus for use with Lineage Power batteryplant controllers in forming an energy reserve system and redundant I²C communications bus for use with a customer's controller. This flexible and sophisticated feature set makes this front-end power supply an excellent choice for power in a variety of application spaces.

Applications

- Enterprise networks
- Telecom equipment
- Power over Ethernet
- VoIP/soft switches
- SAN/NAS/iSCSI applications
- LAN/WAN/MAN applications
- Indoor wireless
- Routers and switches

Key Features

- Compact 1RU form factor
- PMBus compliant dual I²C and RS485 serial bus communications
- Front panel LED indicators
- Internal variable-speed fan control
- Constant power; 52 – 58 Vdc
- Programmable output voltage; 44 – 58 Vdc
- Universal AC input
- PoE compliant
- CE marked
- RoHS 6 compliant
- Hot pluggable

Specifications

Input	
Voltage Range - Low-Line - High-Line	85 – 175 Vac (1200W) 176 – 275 Vac (2000W)
Input Frequency	47 – 63 Hz
Input Current	13.3 Arms @ 100Vac 11.2 Arms @ 120Vac 11.8 Arms @ 200Vac 13.1 Arms @ 240Vac
Inrush Transient	25 Apk typical
Input Leakage Current – CP2000	1.5 mA
Total Harmonic Distortion (THD)	< 5%
Power Factor	0.98 typical
Holdup Time	15 ms @ 75% full power 20 ms (loads below 1200W)
EMC Conducted	FCC and CISPR22 (EN55022) Class A

Output	
Voltage Default	54 Vdc
Voltage Adjust Range - Hardware set via margin pin - I ² C or RS485 set	44 – 58 Vdc 42 – 58 Vdc
Rated Output Current – CP2000 - Low-Line - High-Line	22.2 Adc, 54V 37 Adc, 54V
Rated Output Power – CP2000 - Low-Line - High-Line	1200 Watts 2000 Watts
Psophometric Noise	2 mVrms max
Ripple (5Hz to 20MHz) - RMS - Peak-to-Peak	250 mVrms 500 mVpk-pk
Overvoltage Protection - Delayed - Immediate	60 Vdc 65 Vdc
Over Temperature - Warning - Shutdown	5°C 20°C

Mechanical	
Length (in./mm)	13.85 / 351.2
Width (in./mm)	4 / 101.6
Height (in./mm)	1.63 / 41.4
Weight (lb / kg)	5 / 2.27











Environmental	
Operating Temperature	-40°C ¹ to +75°C (-40 to 167 °F)
Storage Temperature	-40°C to +85°C (-40 to 185 °F)
Power De-Rating	> +55°C (derates @ 2% per °C)
Relative Humidity	95% max, non-condensing
Altitude	4,000m max (13,000 ft)
Audible Noise	55dBA, typical

1. Designed to start at an ambient as low as -40°C but may not meet operational limits until above -5°C.

General	
Cooling	Internal variable-speed fan cooled
Efficiency	90% @ 100 Vac (Vout >52V, Pout >50%) 93% @ 230 Vac (Vout >52V, Pout)
Heat Dissipation	151W / 514 BTU

Safety and Standards Compliance	
Zone 4	Per Telcordia GR-63-CORE, all floors when installed in CPL shelf
Safety	CE mark to Low Voltage Directive 2006/95/EC UL 609501-1 Recognized CAN/CSA C22.2 No. 60950-1-03 Certified VDE 0805-1 Licensed to IEC60950-1
RoHS	Compliant to RoHS EU Directive 2002/95/EC
EMC	FCC and CISPR22 (EN 55022) Class A
ESD	EN/IEC 61000-4-2 Level 3

Front Panel LEDs

Symbol	Analog Mode	I ² C Mode	RS485 Mode
			On: Input OK Blinking: Input out of limits
			On: Output OK Blinking: Overload
	On: Over-temperature warning	On: Over-temperature warning Blinking: Service	On: Over-temperature warning
	 On: Fault		On: Output OK Blinking: Overload

Dimensions

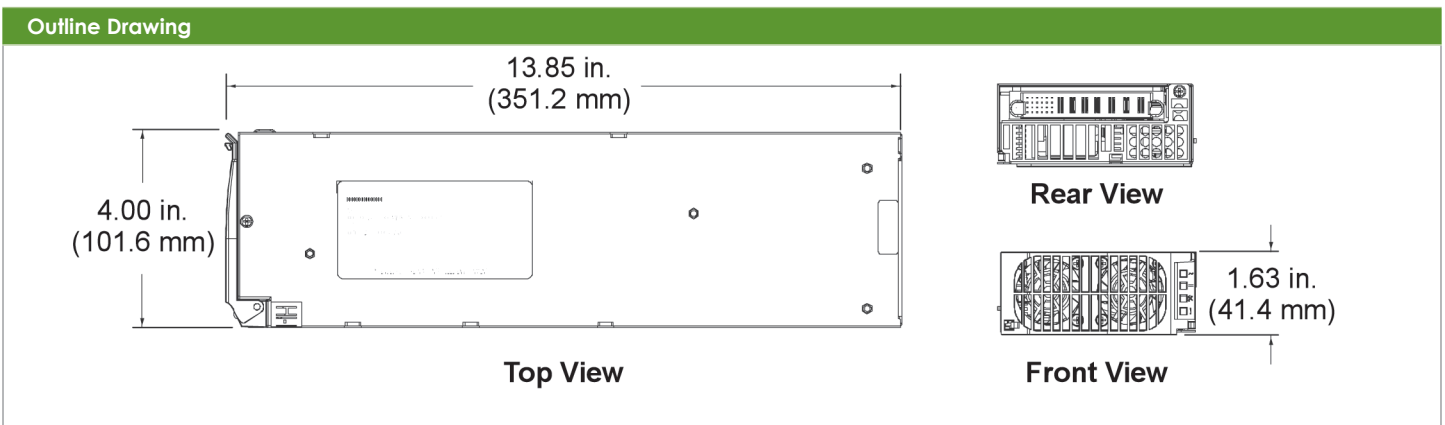

CPL DC-DC Converter



The CPL DC to DC converter is specifically designed to convert a wide range 48V input voltage to a regulated 48V output voltage. The high-density, front-to-back airflow power entry module (PEM) is designed for minimal space utilization and is highly expandable for future growth.

The DC-DC converter is available with many features including PoE isolation and dual-redundant I²C communications bus for use with a customer's controller. This flexible and sophisticated feature set makes this DC PEM an excellent choice for power in a variety of application spaces requiring modular DC-to-DC bulk intermediate voltages.

Applications

- Enterprise networks
- Telecom equipment
- Power over Ethernet
- VoIP/soft switches
- SAN/NAS/iSCSI applications
- LAN/WAN/MAN applications
- Indoor wireless
- Routers and switches

Key Features

- Compact 1RU form factor
- PMBus compliant dual I²C serial bus communications
- Front panel LED indicators
- Internal variable-speed fan control
- Input current < 60A @ 40Vdc input
- Programmable output voltage; 44 – 58 Vdc
- CE marked
- RoHS 5 compliant
- Hot pluggable

Input	
Operating Voltage	-40 to -72 Vdc
Input Current	60 Adc @ input voltage >40Vdc
Cold Start Inrush Current	60 Adc
Low Input Shutdown of Main Output	-39 Vdc typical
Input Turn-On of Both Outputs	-43.5 Vdc typical
Reverse Input Voltage	Module not damaged
Idling Power - Output OFF - Output ON	35W (5Vdc output @ no load) 60W (Both outputs @ no load)
Holdup Time	8 ms (min Vin = 48Vdc, output @ ½ full load)
Ride Through	8 ms (min Vin = 48Vdc, output @ ½ full load)
Input Capacitance	25 µF max

General	
Cooling	Internal variable-speed fan cooled
Efficiency	90% typical, 75 – 100% of full load 84% typical, loads > 25% of full load
Heat Dissipation	222W / 758 BTU

Output	
Maximum Output Power	2000 Watts
Output Voltage Setpoint	54 Vdc
Output Voltage Range	44 – 58 Vdc
Output Current	37A max @ 54Vdc
Active Current Share	-5 – 5% FL (single wire connection)
Passive Current Share	-15 – +15% FL (without single wire connection)
Ripple (5Hz to 20MHz) - RMS - Peak-to-Peak	250 mVrms 500 mVpk-pk
External Bulk Load Capacitance	5000 µF max
Turn-On - Delay - Rise Time - Overshoot	5 s typical 500 ms typical 5% max
Restart Shutdown Delay	20 s typical
Overload - Current Limit - Shutdown	38.9 – 43 Adc 39 Adc max
Overvoltage - Delayed - Instantaneous	60 Vdc 65 Vdc
Over Temperature - Warning - Shutdown	5°C typical 20°C minimum











Mechanical	
Length (in./mm)	13.85 / 351.2
Width (in./mm)	4 / 101.6
Height (in./mm)	1.63 / 41.42
Weight (lb / kg)	4.6 / 2.1

Environmental	
Operating Temperature	-40°C ¹ to +75°C (-40 to 167 °F)
Storage Temperature	-40°C to +85°C (-40 to 185 °F)
Power Derating	> +55°C (derates @ 1% per °C)
Relative Humidity	95% max, non-condensing
Altitude	4,000m max (13,000 ft)
Audible Noise	55dBA, typical

Safety and Standards Compliance	
Zone 4	Per Telcordia GR-63-CORE, all floors when installed in CPL shelf
Safety	CE mark to Low Voltage Directive 2006/95/EC UL 60950-1-1 Recognized CAN/CSA C22.2 No. 60950-1 VDE 0805-1 Licensed to IEC60950-1
RoHS	Compliant to RoHS EU Directive 2002/95/EC
EMC	FCC and CISPR22 (EN 55022) Class A
ESD	EN/IEC 61000-4-2

1. Designed to start at an ambient as low as -40°C but may not meet operational limits until above -5°C.

Front Panel LEDs

Symbol	Analog Mode	I ² C Mode	RS485 Mode
			On: Input OK Blinking: Input out of limits
			On: Output OK Blinking: Overload
	On: Over-temperature warning	On: Over-temperature warning Blinking: Service	
	 On: Fault 		

Dimensions

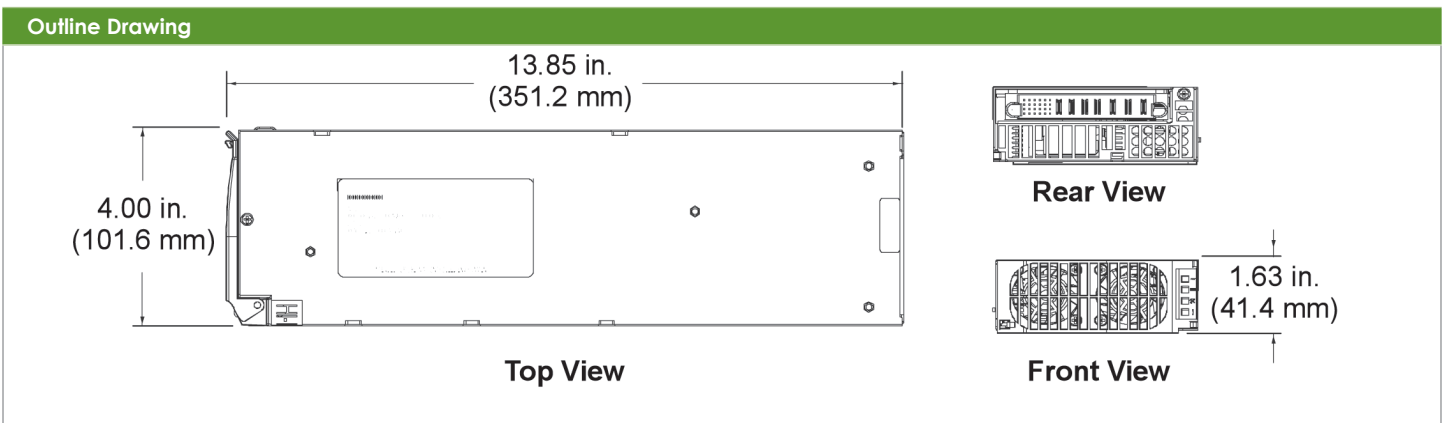

Pulsar Edge Controller

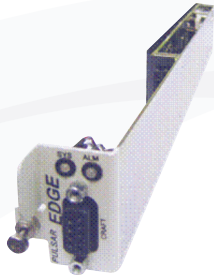

The CPL Pulsar Edge controller delivers large system intelligence in a small system form factor. This family of controllers functions as a network interface controller (NIC) and as a full-featured battery plant controller to the Compact Power Line (CPL) platform. Its thin modular plug-in form factor minimizes shelf space consumption allowing maximum power module and distribution capabilities yet provides nearly all the features found in controllers used in much larger power systems.

The Pulsar Edge CP841A controller is utilized in bulk power applications in data centers and enterprise applications. Ethernet connectivity with SNMP facilitates remote network management access through its front-accessible RS232 or USB port and is aided by the EasyView2 graphical user interface.

As a battery plant controller, it provides a complete set of features to monitor and control rectifiers, batteries, and distribution. A flexible set of configurable inputs allow the CP841A to monitor a wide variety of system equipment and incorporate appropriate state information enabling a centralized point of management.

The controller utilizes standard network management protocols allowing for advanced network supervision. Lineage Power Galaxy Manager™ software is the centralized visibility and control component of a comprehensive power management system designed to meet engineering, operations, and maintenance needs. The Galaxy Manager client-server architecture enables remote access to system controllers across the power network.

Applications

- Enterprise Networks - Voice, Data, PoE
- Telecommunications networks
- Transmission equipment
- Fiber in the loop
- Routers/switches
- Data networks
- PBX

Key Features

Remote Access and Features

- Integrated 10/100Base-T Ethernet Network
 - TCP/IP
 - SNMP V2c for management
 - SMTP for email
 - Telnet for command line interface
 - DHCP for plug-n-play
 - FTP for rapid backup and upgrades
 - HTTP for standard web pages and browsers
 - Compatible with Galaxy Manager and other management packages
 - Shielded RJ-45 interface referenced to chassis ground
- Password protected security levels: User, Super-User, Administrator for all access
- Ground-referenced RS232 system port
- ANSI T1.317 command-line interface
- Modem access support
 - Remote via external modem
 - Callback security
- EasyView2, Windows-based GUI software for local terminal or Modem access

Standard System Features

- Monitor and control of more than 40 connected devices
 - Maximum of 32 rectifiers
 - Maximum of 6 distribution control cards
 - Robust RS485 system bus
- Standard and user defined system alarms
 - Alarm test
 - Assignable alarm severity: Critical, Major, Minor, Warning, and Record-only
- Rectifier management features
 - Automatic rectifier restart
 - Active Rectifier Management (energy efficiency)
 - Remote rectifier (on/off)
 - Reserve Operation
 - Automatic rectifier sequence control
 - N + X redundancy check
- Multiple Low Voltage Load and Low Voltage Battery Disconnect thresholds (4)
- Configuration, statistics, and history
 - All stored in non-volatile memory
 - Remote/local backup and restore of configuration data
- Industry standard defaults
 - Customer specific configurations available
- Remote/ local software upgrade
- Basic, busy hour, and trend statistics
- Detailed event history
- User defined events and derived channels

Standard Battery Management Features

- Float/boost mode control
 - Manual boost
 - Manual timed boost locally, T1.317, and remotely initiated
 - Auto boost terminated by time or current
- Battery discharge testing
 - Manual (local/remote)
 - Periodic
 - Plant Battery Test (PBT) input driven
 - Configurable threshold or 20% algorithm
 - Graphical discharge data
 - Rectifiers on-line during test
- Slope thermal compensation
 - High temperature
 - Low temperature
 - Step temperature
 - STC Enable/Disable, low temperature Enable/Disable
 - Configurable mV/°C slopes
- State of charge indication
- High temperature disconnect setting
- Reserve-time prediction
- Recharge current limit
- Emergency Power-Off input

Integrated Monitoring Inputs/Outputs

- System plant voltage (accuracy $\pm 0.5\%$, resolution 0.01V)
- One system shunt (accuracy $\pm 1\%$ full scale, resolution 1A)
 - Battery or load
 - Mounted in the return side of DC bus
- Up to 15 binary inputs
 - Six inputs close/open to battery
 - 9 input close/open to return (number is dependent upon number of output alarms)
 - User assignable
- Up to 5 user assignable Form-C output alarms (50VDC @ .3A)
- 1-Wire™ bus devices
 - Up to 16 temperature probes (QS873)
 - Up to 6 mid-string monitors (ES771)

Galaxy Manager Compatible

- Centralized web server and database with multiple user access to live or managed data with drill down to problem details
- Monitor and control of more than 40 connected devices
- Management information from polling or alarms received from alarm traps from multiple sites are available on one screen via the inter/intranet
- Trend user selected data over time
- Automatic or manual report generation
- Standard engineering tools like reserve time calculators and cable voltage drop analyzer

General	
Operating Voltage	± 24 Vdc, ± 48 Vdc (Range: ± 18 to ± 60 Vdc)
Input Power	Less than 7W
Operating Temperature Range	-40°C to +75 °C (-40 to 167 °F)
Storage Temperature Range	-40°C to +85°C (-40 to 185 °F)
Operating Relative Humidity	0 - 95% (non-condensing)
Physical Specifications	1.75 in. H, 0.75 in. W, 8.00 in. D; 0.5lb 45mm H, 20mm W, 204mm D; 227g
Display	8-line by 40-character backlit LCD

Agency Certifications	
Radiated Emissions	FCC, Class B; EN 55022, Class B
Safety	UL Unlisted Component as Part of CPL or SPS Power System
RoHS	Compliant to RoHS EU Directive 2002/95/EC
EMC	FCC/EN55022 Class B, CISPR22 Level B
ESD	EN 61000-4-2 level 4

Notes:

Area with horizontal dotted lines for taking notes.

Ordering Information – Compact Power Line

48V DC Critical Power Solution

The Compact Power Line platform is designed to provide highly reliable DC power for 48V distributed power architectures. A single shelf configuration provides up to 11kW of 48V output power in 1U high and mounts in 19-inch or 23-inch wide frames. The CPL product platform is easily expandable for future growth. CPL is a reliable DC power solution for mission-critical enterprise and telecommunications network equipment.

The CPL product line provides several shelf options. J85480S1 shelves have four slots for either rectifiers or converters (PEMs). These shelves are primarily used without a controller or with

a customer's controller using I2C communications. J2007001 shelves have four slots with space for a full-feature Pulsar Edge Network Interface Controller (NIC). The Pulsar Edge controller has Ethernet connectivity with SNMP to facilitate remote network management to monitor and control rectifiers, batteries, and distribution. These shelves are used with either shelf mounted distribution or external distribution panels for small battery plant applications.

Features – Model J85480S1

- Fits into a standard 19" rack
- Two DC Outputs may be common or split. Each output bus is rated for 100A with two-hole lug landings for 2 AWG wire.
- Choose between IEC-320 C13 or C19 AC input connections.
- Analog or dual/redundant I²C communications.
- Adjustable mounting ears for either flush front or multiple set back positions.

Features – Model J2007001



- Fits into a standard 19" rack
- Single DC output rated for 200A with two-hole lug landings for up to 2/0 AWG cable.
- Choose between IEC-320 or Molex Mini-Fit SR for AC input. Single, dual or quad input feeds
- RS485 communications.
- Adjustable mounting ears with multiple set back positions.
- Up to 3 shelves may be interconnected with bus straps for DC outputs for a 600A system
- Plug-N-Play CP841A controller with front access craft port, rear access LAN and alarm connections
- Select Shelves include distribution modules

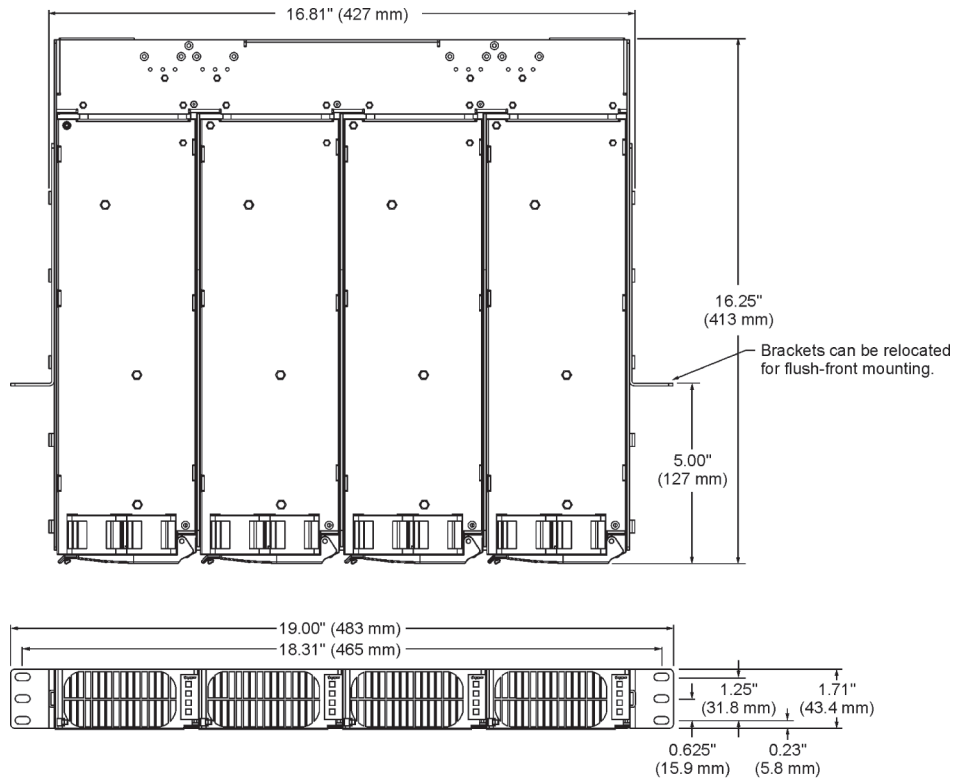

Shelf Line Drawing – J85480S1 Shelves



J85480S1 Shelf Options

List	Max Rectifier Size	AC Input	DC Output	Rear View of Shelf
20	2725 Watts	IEC-320, C19 Cords	Common Bus (Lugs)	
21	2725 Watts		Split Bus (Lugs)	
23	2000 Watts	IEC-320, C13 Cords	Common Bus (Lugs)	
27	2000 Watts		Split Bus (Lugs)	
14	CC109124764	None DC Input	Split Bus (Lugs)	 Converter (PEM) Shelf

- Notes:**
- CP2725 rectifiers not recommended for use with shelves having C13 AC inputs.
 - J85480S1 shelves communication protocol - Analog (no controller), I2C (customer supplied controller).
 - List 23 shelf is POE compliant.
 - Split bus shelves cannot be paralleled. Two common bus shelves may be connected together.
 - Other J85480S1 shelves are stackable up to 8 shelves to accommodate 32 paralleled power supplies. Contact your Lineage Power Sales Representative for additional information.
 - In controller-less applications, shelves are fixed output to ±54Vdc. Contact your Lineage Power Sales Representative for shelf configurations with ±48Vdc fixed output.
 - Other J85480S1 shelf configurations are available for use with Lineage Pulsar Plus controllers. Contact your Lineage Power Sales Representative for additional information.

DC Output Types – J85480S1 Shelves

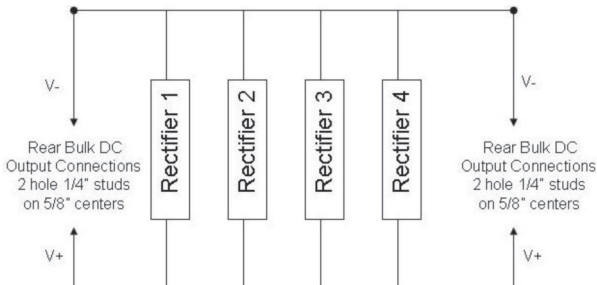
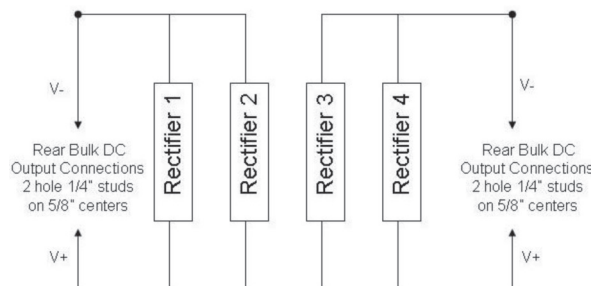
Description	Schematic
Common Output Bus for Terminal Lug Connection	
<ul style="list-style-type: none"> Each Lug Connection rated for 100A with 2 gage wire (200A for shelf) 	
Split Output Bus for Terminal Lug Connection	
<ul style="list-style-type: none"> Vdc (-) has Split buses Vdc (+) is common to both sections. Each bus may be independently controlled Multiple shelves may not be paralleled together. Each Lug Connection rated for 100A with 2 gage wire (200A for shelf) 	

Communication Signals – J85480S1 Shelves

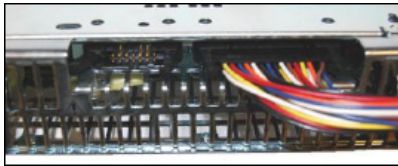



J1 CONNECTOR – Pin Out			
Pin	Signal	Pin	Signal
1	POWER_CAP_1	16	SDA_1
2	POWER_CAP_2	17	Fault
3	POWER_CAP_3	18	Alert#_0
4	POWER_CAP_4	19	Enable side B
5	MOD_PRES_1	20	Logic_GRD
6	MOD_PRES_2	21	Enable Side A
7	MOD_PRES_3	22	Logic_GRD
8	MOD_PRES_4	23	Alert#_1
9	PFW_1	24	5VA
10	PFW_2	25	OTW
11	PFW_3	26	Reset
12	PFW_4	27	Iso. barrier n/c
13	SCL_0	28	Iso. barrier n/c
14	SCL_1	29	Shelf_Addr_B
15	SDA_0	30	Shelf_Addr_A

J2 CONNECTOR – Pin Out			
Pin	Signal	Pin	Signal
1	SCL_0	8	Alert#_1
2	SCL_1	9	Isolation n/c
3	SDA_0	10	Isolation n/c
4	SDA_1	11	Ishare - B
5	Alert#_0	12	Ishare - A
6	5VA	13	8V_INT - B
7	Logic_GRD	14	8V_INT - A

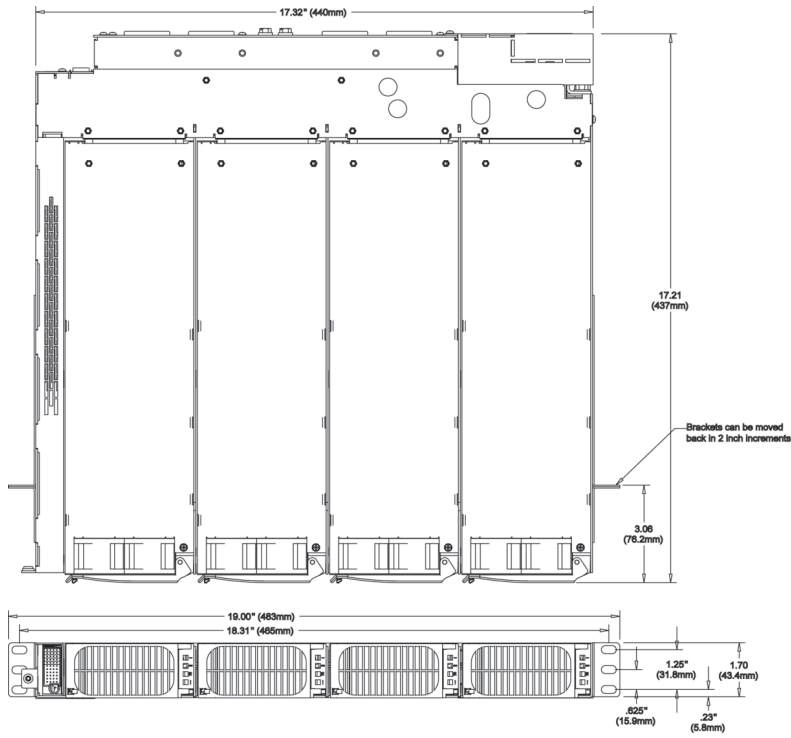
Shelf Line Drawing – J2007001 Shelves

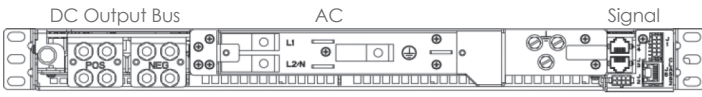
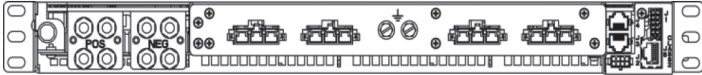

J2007001 Shelf Options

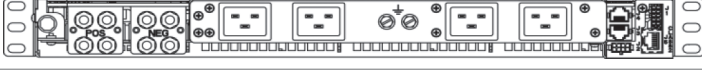
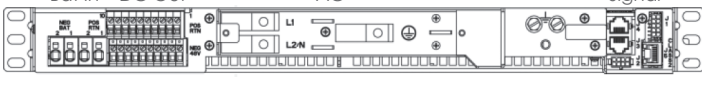
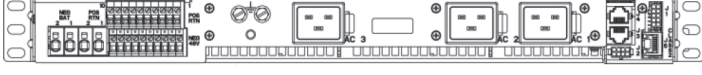
List	Max Rectifier Size	AC Input	DC Output	Rear View of Shelf
3	2725 Watts	Single AC feed (terminal blocks for 6ga wire and 3/4\" conduit fitting)	DC output bus is rated for 200A for two 2ga or one 2/0 gage two-hole lugs (1/4-20 studs on 5/8\" centers).	
4	2725 Watts	Individual feed (Molex Mini-Fit SR)		
5	2725 Watts	Dual feed (Molex Mini-Fit SR)		
6	2725 Watts	Individual feed (IEC-320 C19 Cords)		
7	2725 Watts	Single AC feed (terminal blocks for 6ga wire and 3/4\" conduit fitting)	2 battery input - terminal blocks for 8ga wire, 30A breakers, LVBD. Ten load output – terminal blocks for 12ga wire, 10 GMT fuses rated 10A each	
7A	2725 Watts	Individual feed (IEC-320 C19 cords)		

- Notes:**
- CP841A Pulsar Edge Controller ships separately.
 - Up to 3 shelves may be interconnected.

J2007001 Shelves System Controller

Several versions of the CP841A Pulsar Edge controller are available. Each offers different alarm input/outputs on the J1 connector of the shelf.

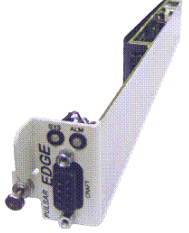
CP841A_9C0R	J1 has 9 alarm inputs with a common return and no output relays	
CP841A_3C3R	J1 has 3 alarm inputs with a common return and 3 output relays; Power Major, Power Minor, 1 Selectable	
CP841A_0I5R	J1 has 0 alarm inputs and 5 output relays; Power Major, Power Minor, 3 Selectable	

Communication Signals for J2007001 Shelves

- J1 provides alarm outputs and inputs based on the controller installed (see table below). Inputs are “Dry”, no voltage, contact Closures or Opens to a common return on pin 6. Outputs are relay contacts. Both input and output alarms are customer defined on the controller’s web pages.
- J2 provides alarm inputs (see table below). Alarm inputs are contact Closures or Opens to the non-grounded side of the dc bus [-48V]. Pins 6, 7, 8 provide -48V for these alarm inputs.
- J3 battery thermal probe (QS873A) or battery mid-string voltage monitor (ES771) with battery thermal probe.
- J4 shelf to shelf communication connection
- J5 LAN/Ethernet.
- J7 provides distribution control for shelves with external distribution. See table below.

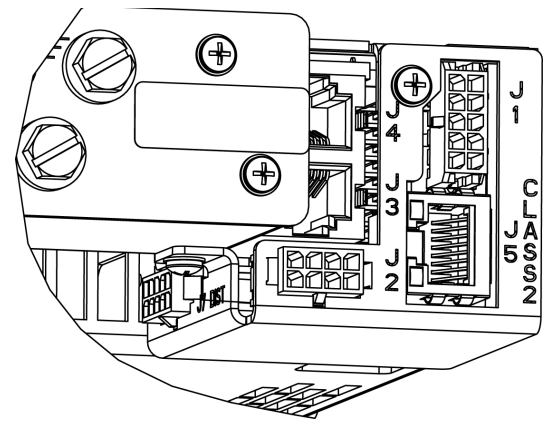

J1 CONNECTOR – Pin Out		
Pin	Signals for SPS841A_3C3R	Signals for SPS841A_0I5R
1	ALM1 Input	Alarm Relay 3 Rtn
2	ALM2 Input	Alarm Relay 2 Rtn
3	Alarm Relay 1 Rtn	Alarm Relay 1 Rtn
4	Power Minor Rtn	Power Minor Rtn
5	Power Major Rtn	Power Major Rtn
6	ALM1, 2, 6C RTNS	Alarm Relay 3
7	ALM6 Input	Alarm Relay 2
8	Alarm Relay 1	Alarm Relay 1
9	Power Minor	Power Minor
10	Power Major	Power Major

J2 CONNECTOR	
Pin	Signal
1	ALM6 Input
2	-
3	ALM3 Input
4	ALM4 Input
5	ALM5 Input
6	-48V
7	-48V
8	-48V

J7 CONNECTOR	
Pin	Signal
1	FAJ
2	Coil Rtn
3	LVD_NC
4	LVD_NO
5	Shunt-
6	OS
7	Coil1
8	Coil2
9	LVD Status Rtn
10	Shunt+

Battery Monitoring

Temperature/Voltage probes are needed for battery monitoring. They are connected to each battery or battery string to provide slope thermal compensation, temperature alarms and voltage imbalance alarms. Refer to ordering guide for diagram and part numbers.

J85480S1 Shelf Ordering Guide

Mounting Brackets	
1U bracket for 23" frame mount	CC848844803
2U bracket for 23" frame mount	848683009
Wall mount bracket	CC848864504

Communication Cables	
10' Communication Cable (J1)	CC848854034
Shelf to shelf communication cable (J2)	CC848848952

AC Input, DC Output Cables	
C13 plug with 5-15P plug, 10'	CC848776105
C13 plug with L6-20P plug, 10'	CC848820317
C13 plug, unterminated, 10'	847861192
C19 plug, with 5-15P plug, 8'	CC848850792
C19 plug, with L6-20P plug, 8'	CC848850842
C19 plug, unterminated, 8'	CC848847368
DC output cable, 2gauge, 10'	848748987

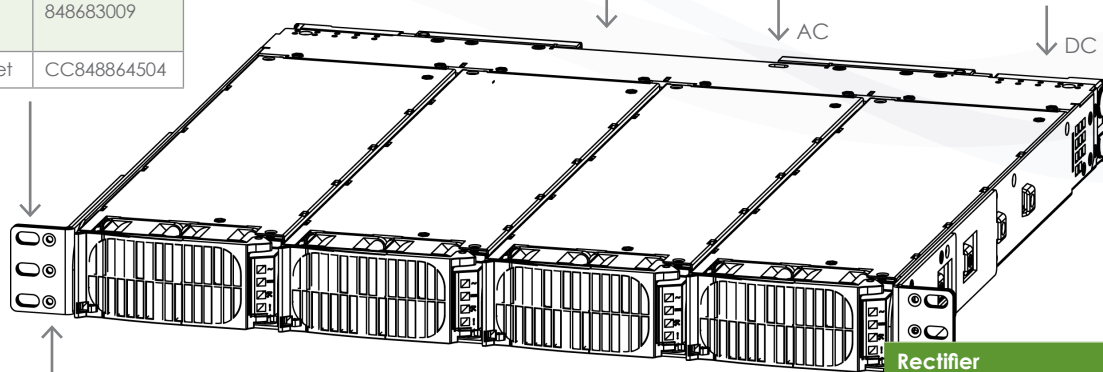

Rectifier Shelf Options	
List 20	CC109147344
List 21	CC109147328
List 23	CC109150447
List 27	CC109155743

Rectifier	
CP2000AC54PE	CC109120722
CP2725AC54Z	CC109142873
CP2725AC54HEZ	CC109149423
Rectifier Slot Filler	
Central Office White	CC848822263
Raven Black	CC848781534
Graphite	CC848825233

J85480S1 Converter Shelf Ordering Guide

Mounting Brackets	
1U bracket for 23" frame mount	CC848844803
Wall mount bracket	CC848864504

DC Input Cables	
DC input cable, 10gauge, 4'	CC848794908

DC Output Cables	
DC output cable, 2gauge 10'	848748987
DC Bus for 1/4" Faston Connections (2 required)	CC848886192

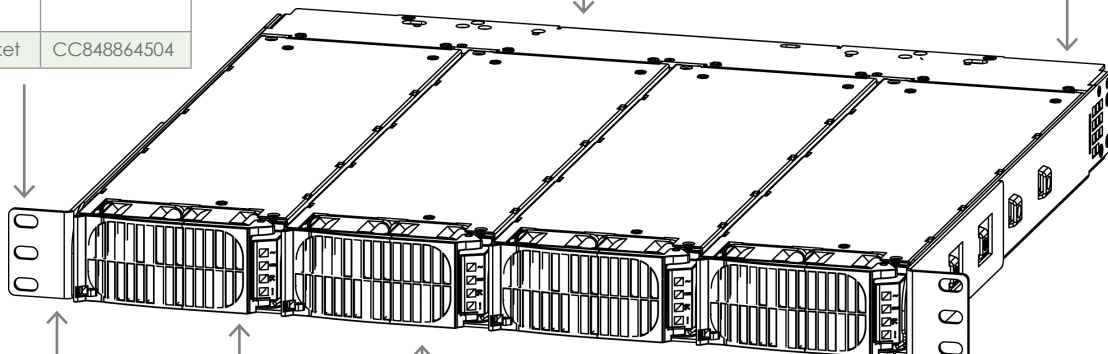

Converter Shelf Options	
List 14	CC109124764

Converter (PEM) Options	
CP2000DC54PE	CC109146692
Rectifier Slot Filler	
Central Office White	CC848822263
Raven Black	CC848781534
Graphite	CC848825233

**J2007001 Shelf
Ordering Guide**

Mounting Brackets

1U bracket for 23" frame mount	CC848844803
2U bracket for 23" frame mount	848683009
Wall mount bracket	CC848864504

Alarm and Communication Cables

15' Alarm or distribution cable (J1 or J7)	CC848865980
50' Alarm or distribution cable (J1 or J7)	CC848817651
150' Alarm or distribution cable (J1 or J7)	CC848817668
15' Alarm input cable (J2)	CC848853614
Shelf to shelf communication cable (J3, J4)	CC848847780

AC Input, DC Output Cables

C19 plug, with 5-15P plug, 8'	CC848850792
C19 plug, with L6-20P plug, 8'	CC848850842
C19 plug, unterminated, 8'	CC848847368
Molex Mini-Fit SR, unterminated, 8awg, 10' (2 cables provided)	848710711
DC output cable, 2ga, 10'	848748987
DC Bus Bar Strap (2 required)	CC848844324

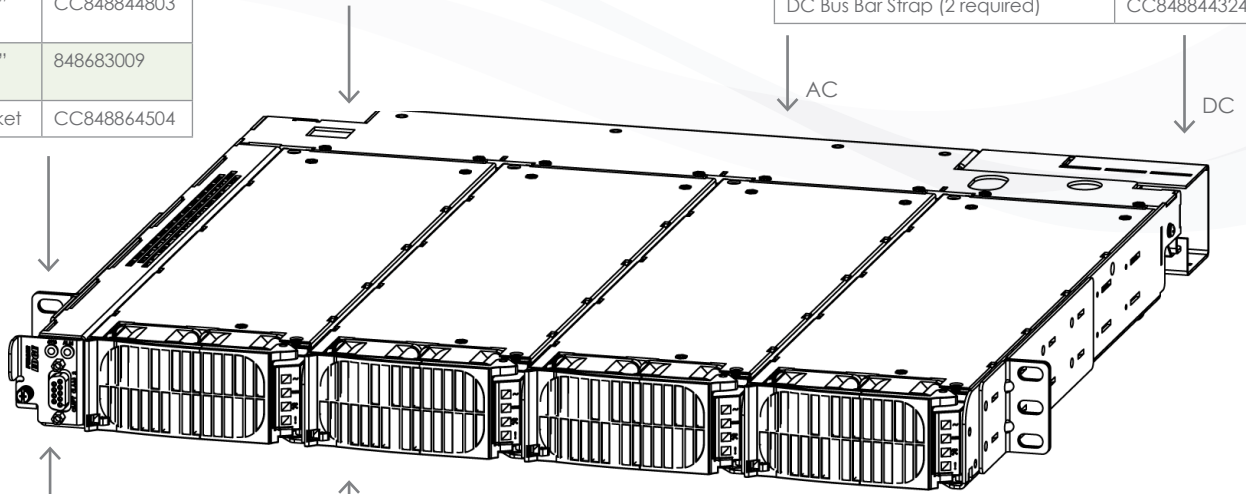

Controller

CP841A_9C0R	CC109140068
CP841A_3C3R	CC109145331
CP841A_0I5R	CC109145356
Slot Filler	CC848847871

Rectifier

CP2000AC54PE	CC109147542
CP2725AC54Z	CC109142873
CP2725AC54TEZ	CC109149423

Rectifier Slot Filler

Central Office White	CC848822263
Raven Black	CC848781534
Graphite	CC848825233

Rectifier Shelf Options

List 3	CC109147542
List 4	CC109140043
List 5	CC109140051
List 6 (Shown)	CC109140027

Rectifier Shelves with distribution

List 7 Rectifier/Distribution	CC109151775
List 7A Rectifier/Distribution	CC109151841

Battery Management Accessories

A: QS873A Thermal Probe	CC109142980
B: 10' probe to controller wireset	CC848817024
C: 1' probe to probe wireset	CC848822560
C: 5' probe to probe wireset	848719803
C: 10' probe to probe wireset	CC848822321
ES771A Voltage Monitor Card	108958422
D: 2 1/2' ES771A to probe wireset	CC848791517
D: 6' ES771A to probe wireset	CC848797290
D: 10' ES771A to probe wireset	848719829
G: 4' ES771A to ES771A or controller wireset	CC848791500
G: 10' ES771A to ES771A or controller wireset	848652947

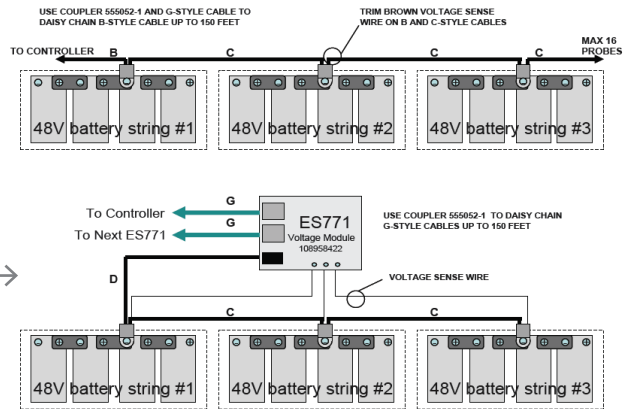

Specifications

Rectifiers

Power Module	Output Power/Input Voltage	Output Voltage	Protection	Physical
CP2000AC54PE CP2000AC54PEZ	2000W / 200-240VAC 1200W / 100-120VAC	Hardware set 44 - 58Vdc	15A breaker, 14 gauge wire	Length: 13.85"/351.8mm Width: 4.00"/101.6mm Height: 1.66"/42.2mm Weight: 4.6lb/2.1kg
CP2725AC54Z	2725W / 200-240VAC 1200W / 100-120VAC		20A breaker, 12 gauge wire	
CP2725AC54TEZ	2725W / 200-240VAC 1200W / 100-120VAC	Software set 42 - 58Vdc		
CP2000DC54-PE	2000W / 40-72VDC		60A breaker, 8 gauge wire	

NOTES: PE suffix denotes PoE compliance. Z suffix denotes RoHS 6 compliance. TE suffix denotes total efficiency.

Shelves

Mechanical	J85480S-1	J2007001
Height	1.71 inches/43.4mm	1.71 inches/43.4mm
Width (with mounting ears)	19 inches/483mm	19 inches/483mm
Depth	16.25 inches/413mm	17.06 inches/433mm
Weight (without rectifiers)	9.25lbs/4.2kg	8.75lbs/4.0kg
Environmental	J85480S-1	J2007001
Operating Temperature Range	List 14: -40°C to 75°C (-40 to 167 °F) Lists 20, 21: -40°C to 25°C (-40 to 77 °F) [Commercial 60°C C19 AC cord] -40°C to 55°C (-40 to 131 °F) [High Temp C19 AC cord] Lists 23, 27: -40°C to 25°C (-40 to 77 °F) [Commercial 60°C C13 AC cord] -40°C to 55°C (-40 to 131 °F) [High Temp C13 AC cord]	Lists 6, 7A: -40°C to 25°C (-40 to 77 °F) [Commercial 60°C C19 AC cord] -40°C to 55°C (-40 to 131 °F) [High Temp C19 AC cord] Lists 3, 4, 5, 7: -40°C to 55°C (-40 to 131 °F)
Operating Relative Humidity	0 - 95% (non-condensing)	
Storage Temperature Range	-40°C to 85°C (-40 to 185 °F)	
EMC	FCC, EN 55022, CISPR22, Level A, conducted and radiated	
Immunity	EN55024 (CISPR24) Class A, conducted and radiated	
Safety/Standards Compliance	J85480S-1	J2007001
Safety Standards	CAN/CSA C22.2 No. 60950-1-03, UL 60950-1, 1st Edition VDE IEC 60950-1, 1st Edition	
Certification Marks	Lists 14, 20, 21, 23 VDE List 14 UL Recognized (Canada and U.S.) Lists 20, 21, 23 UL Listed (Canada and U.S.)	Lists 4, 5, 6 VDE Lists 4, 5 UL Recognized (Canada and U.S.) List 6 UL Listed (Canada and U.S.)

* All Lineage CP AC cords are High Temperature cords.

Management Visibility

Galaxy Manager™ software is the centralized visibility and control component of a comprehensive power management system designed to meet engineering, operations and maintenance needs. The Galaxy Manager client-server architecture enables remote access to system controllers across the power network.

- Dashboard display with one-click access to management information database
- Trend analysis
- Scheduled or on demand reports
- Fault, configuration, asset, and performance management

Training

Lineage Power offers on-site and classroom training options based on certification curriculum. Technical training can be tailored to individual customer needs. Training enables customers and partners to more effectively manage and support the power infrastructure. We have built our training program on practical learning objectives that are relevant to specific technologies or infrastructure design objectives.

Service & Support

Lineage Power field service and support personnel are trusted advisors to our customers – always available to answer questions and help with any project, large or small. Our certified professional services team consists of experts in every aspect of power conversion with the resources and experience to handle large turnkey projects along with custom approaches to complex challenges. Proven systems engineering and installation best practices are designed to safely deliver results that exceed our customers' expectations.

Warranty

Lineage Power is committed to providing quality products and solutions. We have developed a comprehensive warranty that protects you and provides a simple way to get your products repaired or replaced as soon as possible.

CPL comes with a two year hardware warranty. For full warranty terms and conditions please go to www.lineagepower.com/warranty.

Contact Us

For more information, call Lineage Power toll free at **877-LINEAGE (877-546-3243)**, or +1 972 244 9288 and visit us on the Web at lineagepower.com

Lineage Power reserves the right to change specifications without notice. Please contact your Lineage representative to confirm current specifications. Please visit www.lineagepower.com/patents for patents and trademark information.