



- Features :
- AC input range selected by switch
  - Protections: Short circuit / Overload / Over voltage
  - Forced air cooling by built-in DC fan
  - 100% full load burn-in test
  - Fixed switching frequency at 60KHz
  - Low cost
  - High reliability
  - 2 years warranty



**SPECIFICATION**

MODEL	S-250-5	S-250-12	S-250-15	S-250-24	S-250-27	S-250-48	
OUTPUT	DC VOLTAGE	5V	12V	15V	24V	27V	48V
	RATED CURRENT	40A	18A	15A	10A	9A	5.2A
	CURRENT RANGE	0 ~ 40A	0 ~ 18A	0 ~ 15A	0 ~ 10A	0 ~ 9A	0 ~ 5.2A
	RATED POWER	200W	216W	225W	240W	243W	249.6W
	RIPPLE & NOISE (max.) Note.2	80mVp-p	120mVp-p	120mVp-p	120mVp-p	150mVp-p	200mVp-p
	VOLTAGE ADJ. RANGE	4.75 ~ 5.5V	10.8 ~ 13.2V	13.5 ~ 16.5V	21.6 ~ 26.4V	24.3 ~ 29.7V	43.2 ~ 52.8V
	VOLTAGE TOLERANCE Note.3	±2.0%	±1.0%	±1.0%	±1.0%	±1.0%	±1.0%
	LINE REGULATION	±0.5%	±0.5%	±0.5%	±0.5%	±0.5%	±0.5%
	LOAD REGULATION	±1.0%	±0.5%	±0.5%	±0.5%	±0.5%	±0.5%
SETUP, RISE TIME	800ms, 50ms at full load						
HOLD TIME (Typ.)	19ms at full load						
INPUT	VOLTAGE RANGE	90 ~ 132VAC / 176 ~ 264VAC Selected by switch					248~370VDC
	FREQUENCY RANGE	47 ~ 63Hz					
	EFFICIENCY (Typ.)	74%	79%	80%	81.5%	82%	82%
	AC CURRENT (Typ.)	4.8A/115VAC		2.8A/230VAC			
	INRUSH CURRENT (Typ.)	COLD START 45A/230VAC					
LEAKAGE CURRENT	<2mA / 240VAC						
PROTECTION	OVER LOAD	105 ~ 135% rated output power Protection type : Hiccup mode, recovers automatically after fault condition is removed					
	OVER VOLTAGE	5.75 ~ 6.75V	13.8 ~ 16.2V	17.25 ~ 20.25V	27.6 ~ 32.4V	31.05 ~ 36.45V	55.2 ~ 64.8V
ENVIRONMENT	WORKING TEMP.	-10 ~ +60°C (Refer to output load derating curve)					
	WORKING HUMIDITY	20 ~ 90% RH non-condensing					
	STORAGE TEMP., HUMIDITY	-20 ~ +85°C, 10 ~ 95% RH					
	TEMP. COEFFICIENT	±0.03%/°C (0 ~ 50°C)					
	VIBRATION	10 ~ 500Hz, 2G 10min./1cycle, 60min. each along X, Y, Z axes					
SAFETY & EMC	SAFETY STANDARDS	UL60950-1 approved					
	WITHSTAND VOLTAGE	I/P-O/P:3KVAC		I/P-FG:1.5KVAC		O/P-FG:0.5KVAC	
	ISOLATION RESISTANCE	I/P-O/P, I/P-FG, O/P-FG:100M Ohms/500VDC					
OTHERS	MTBF	238.9K hrs min.		ML-HDBK-217F (25°C)			
	DIMENSION	150*140*86mm (L*W*H)					
	PACKING	1.15Kg; 8pcs/10.2Kg/0.97CUFT					
NOTE	<p>1. All parameters NOT specially mentioned are measured at 230VAC input, rated load and 25°C of ambient temperature.</p> <p>2. Ripple &amp; noise are measured at 20MHz of bandwidth by using a 12" twisted pair-wire terminated with a 0.1uf &amp; 47uf parallel capacitor.</p> <p>3. Tolerance : includes set up tolerance, line regulation and load regulation.</p>						

**Mechanical Specification**

Case No. 907C Unit:mm

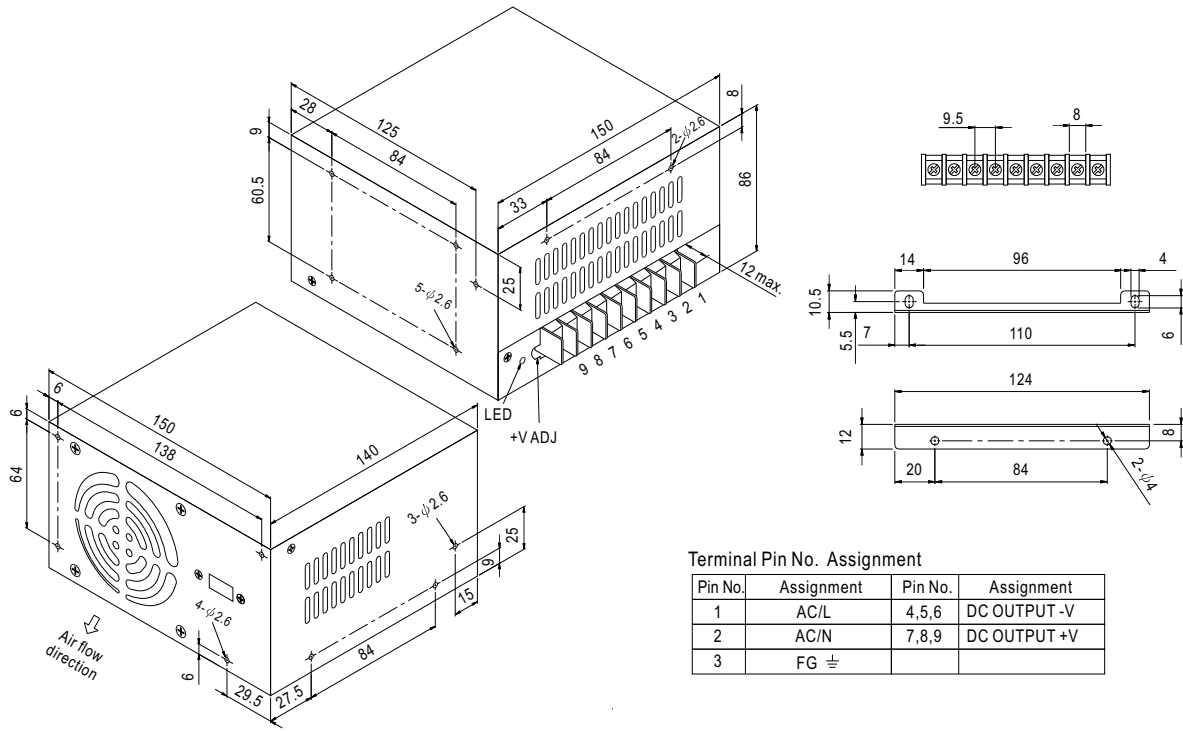

**Block Diagram**

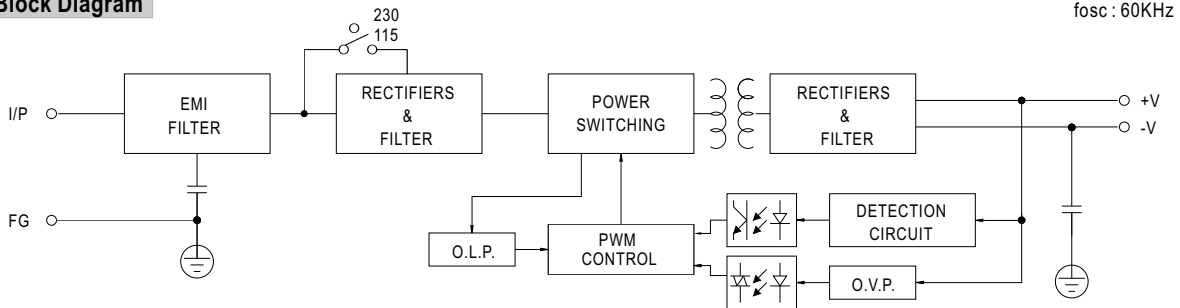

**Derating Curve**

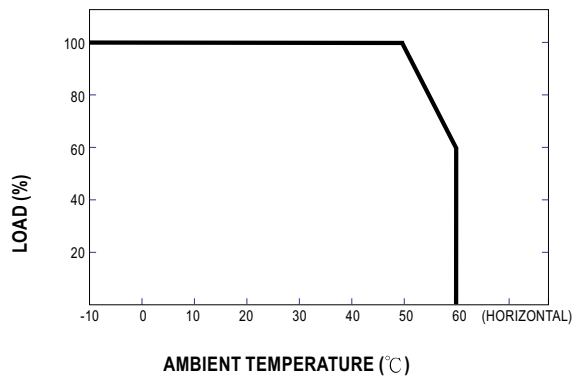

**Static Characteristics**

