

**PKB 4513 Direct Converters**  
 Input 48 V, Output 4 A / 48 W

EN/LZT 146 407 R2A February 2010

© Ericsson AB

**Key Features**

- Industry standard Eighth-brick  
 58.4 x 22.7 x 8.73 mm (2.30 x 0.894 x 0.34 in.)
- Optimized for cold wall thermal management with Gap filler.
- High efficiency, typ. 91.6 % at full load
- 2250 Vdc input to output isolation
- Meets isolation requirements equivalent to basic insulation according to IEC/EN/UL 60950
- More than 1.6 million hours predicted MTBF at +40°C ambient temperature

**General Characteristics**

- Input under voltage protection
- Over temperature protection
- Output short-circuit protection
- Remote control
- Optional latching OTP
- Highly automated manufacturing ensures quality
- ISO 9001/14001 certified supplier

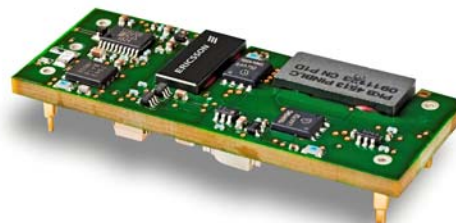

**Safety Approvals**

**Design for Environment**



Meets requirements in high-temperature lead-free soldering processes.

**Contents**

Ordering Information	2
General Information	2
Safety Specification	3
Absolute Maximum Ratings	4
Electrical Specification	
12V, 4A / 48W	5
12V, 4A / 48W, Vin: 30-60V	9
EMC Specification	13
Operating Information	14
Thermal Consideration	15
Connections	15
Mechanical Information	16
Soldering Information	17
Delivery Information	17
Product Qualification Specification	18

<b>PKB 4513 Direct Converters</b> Input 48 V, Output 4 A / 48 W	EN/LZT 146 407 R2A February 2010
	© Ericsson AB

**Ordering Information**

Product program	Output
PKB4513PINB	12 V, 4 A / 48 W

Product number and Packaging

PKB 4513PINB n <sub>1</sub> n <sub>2</sub> n <sub>3</sub> n <sub>4</sub>				
Options	n <sub>1</sub>	n <sub>2</sub>	n <sub>3</sub>	n <sub>4</sub>
Input voltage	o			
Remote Control logic		o		
Lead length			o	
Delivery package information				o

Options	Description
n <sub>1</sub>	36-60V* OV 30-60V
n <sub>2</sub>	Negative, non latching protections OTP, OVP* L Negative, latching OTP, OVP
n <sub>3</sub>	LC 2.79 mm*
n <sub>4</sub>	/B Tray /C Tape and Reel

Example a extend input voltage range, negative logic, short pin product with tray packaging would be PKB4513PINBOVLC/B.

\* Standard variant (i.e. no option selected).

**General Information**

**Reliability**

The Mean Time Between Failure (MTBF) is calculated at full output power and an operating ambient temperature (T<sub>A</sub>) of +40°C, which is a typical condition in Information and Communication Technology (ICT) equipment. Different methods could be used to calculate the predicted MTBF and failure rate which may give different results. Ericsson Power Modules currently uses Telcordia SR332.

Predicted MTBF for the series is:

- 1.6 million hours according to Telcordia SR332, issue 1, Black box technique.

Telcordia SR332 is a commonly used standard method intended for reliability calculations in ICT equipment. The parts count procedure used in this method was originally modelled on the methods from MIL-HDBK-217F, Reliability Predictions of Electronic Equipment. It assumes that no reliability data is available on the actual units and devices for which the predictions are to be made, i.e. all predictions are based on generic reliability parameters.

**Compatibility with RoHS requirements**

The products are compatible with the relevant clauses and requirements of the RoHS directive 2002/95/EC and have a maximum concentration value of 0.1% by weight in homogeneous materials for lead, mercury, hexavalent chromium, PBB and PBDE and of 0.01% by weight in homogeneous materials for cadmium.

Exemptions in the RoHS directive utilized in Ericsson Power Modules products include:

- Lead in high melting temperature type solder (used to solder the die in semiconductor packages)
- Lead in glass of electronics components and in electronic ceramic parts (e.g. fill material in chip resistors)
- Lead as an alloying element in copper alloy containing up to 4% lead by weight (used in connection pins made of Brass)

**Quality Statement**

The products are designed and manufactured in an industrial environment where quality systems and methods like ISO 9000, 6σ (sigma), and SPC are intensively in use to boost the continuous improvements strategy. Infant mortality or early failures in the products are screened out and they are subjected to an ATE-based final test. Conservative design rules, design reviews and product qualifications, plus the high competence of an engaged work force, contribute to the high quality of our products.

**Warranty**

Warranty period and conditions are defined in Ericsson Power Modules General Terms and Conditions of Sale.

**Limitation of Liability**

Ericsson Power Modules does not make any other warranties, expressed or implied including any warranty of merchantability or fitness for a particular purpose (including, but not limited to, use in life support applications, where malfunctions of product can cause injury to a person's health or life).

**© Ericsson AB 2009**

The information and specifications in this technical specification is believed to be correct at the time of publication. However, no liability is accepted for inaccuracies, printing errors or for any consequences thereof. Ericsson AB reserves the right to change the contents of this technical specification at any time without prior notice.

**PKB 4513 Direct Converters**  
Input 48 V, Output 4 A / 48 W

EN/LZT 146 407 R2A February 2010

© Ericsson AB

## Safety Specification

### General information

Ericsson Power Modules DC/DC converters and DC/DC regulators are designed in accordance with safety standards IEC/EN/UL60950, *Safety of Information Technology Equipment*.

IEC/EN/UL60950 contains requirements to prevent injury or damage due to the following hazards:

- Electrical shock
- Energy hazards
- Fire
- Mechanical and heat hazards
- Radiation hazards
- Chemical hazards

On-board DC-DC converters and DC/DC regulators are defined as component power supplies. As components they cannot fully comply with the provisions of any Safety requirements without "Conditions of Acceptability". Clearance between conductors and between conductive parts of the component power supply and conductors on the board in the final product must meet the applicable Safety requirements. Certain conditions of acceptability apply for component power supplies with limited stand-off (see Mechanical Information for further information). It is the responsibility of the installer to ensure that the final product housing these components complies with the requirements of all applicable Safety standards and Directives for the final product.

Component power supplies for general use should comply with the requirements in IEC60950, EN60950 and UL60950 "Safety of information technology equipment".

There are other more product related standards, e.g. IEEE802.3af "Ethernet LAN/MAN Data terminal equipment power", and ETS300132-2 "Power supply interface at the input to telecommunications equipment; part 2: DC", but all of these standards are based on IEC/EN/UL60950 with regards to safety.

Ericsson Power Modules DC/DC converters and DC/DC regulators are UL60950 recognized and certified in accordance with EN60950.

The flammability rating for all construction parts of the products meets requirements for V-0 class material according to IEC 60695-11-10.

The products should be installed in the end-use equipment, in accordance with the requirements of the ultimate application. Normally the output of the DC/DC converter is considered as SELV (Safety Extra Low Voltage) and the input source must be isolated by minimum Double or

Reinforced Insulation from the primary circuit (AC mains) in accordance with IEC/EN/UL60950.

### Isolated DC/DC converters

It is recommended that a slow blow fuse with a rating twice the maximum input current per selected product be used at the input of each DC/DC converter. If an input filter is used in the circuit the fuse should be placed in front of the input filter.

In the rare event of a component problem in the input filter or in the DC/DC converter that imposes a short circuit on the input source, this fuse will provide the following functions:

- Isolate the faulty DC/DC converter from the input power source so as not to affect the operation of other parts of the system.
- Protect the distribution wiring from excessive current and power loss thus preventing hazardous overheating.

The galvanic isolation is verified in an electric strength test. The test voltage ( $V_{iso}$ ) between input and output is 1500 Vdc or 2250 Vdc for 60 seconds (refer to product specification).

Leakage current is less than 1  $\mu$ A at nominal input voltage.

### 48 and 60 V DC systems

If the input voltage to the DC/DC converter is 75 Vdc or less, then the output remains SELV (Safety Extra Low Voltage) under normal and abnormal operating conditions.

Single fault testing in the input power supply circuit should be performed with the DC/DC converter connected to demonstrate that the input voltage does not exceed 75 Vdc.

If the input power source circuit is a DC power system, the source may be treated as a TNV2 circuit and testing has demonstrated compliance with SELV limits and isolation requirements equivalent to Basic Insulation in accordance with IEC/EN/UL60950.

**PKB 4513 Direct Converters**  
 Input 48 V, Output 4 A / 48 W

EN/LZT 146 407 R2A February 2010

© Ericsson AB

**Absolute Maximum Ratings**

Characteristics		min	typ	max	Unit
$T_{P1}$	Operating Temperature (see Thermal Consideration section)	-40		+110	°C
$T_S$	Storage temperature	-55		+125	°C
$V_I$	Input voltage	-0.5		+80	V
$V_{iso}$	Isolation voltage (input to output test voltage)			2250	Vdc
$V_{tr}$	Input voltage transient ( $t_p$ 100 ms)			100	V
$V_{RC}$	Remote Control pin voltage (see Operating Information section)	Positive logic option		6	V
		Negative logic option	-0.5	40	V

Stress in excess of Absolute Maximum Ratings may cause permanent damage. Absolute Maximum Ratings, sometimes referred to as no destruction limits, are normally tested with one parameter at a time exceeding the limits in the Electrical Specification. If exposed to stress above these limits, function and performance may degrade in an unspecified manner.

**Fundamental Circuit Diagram**

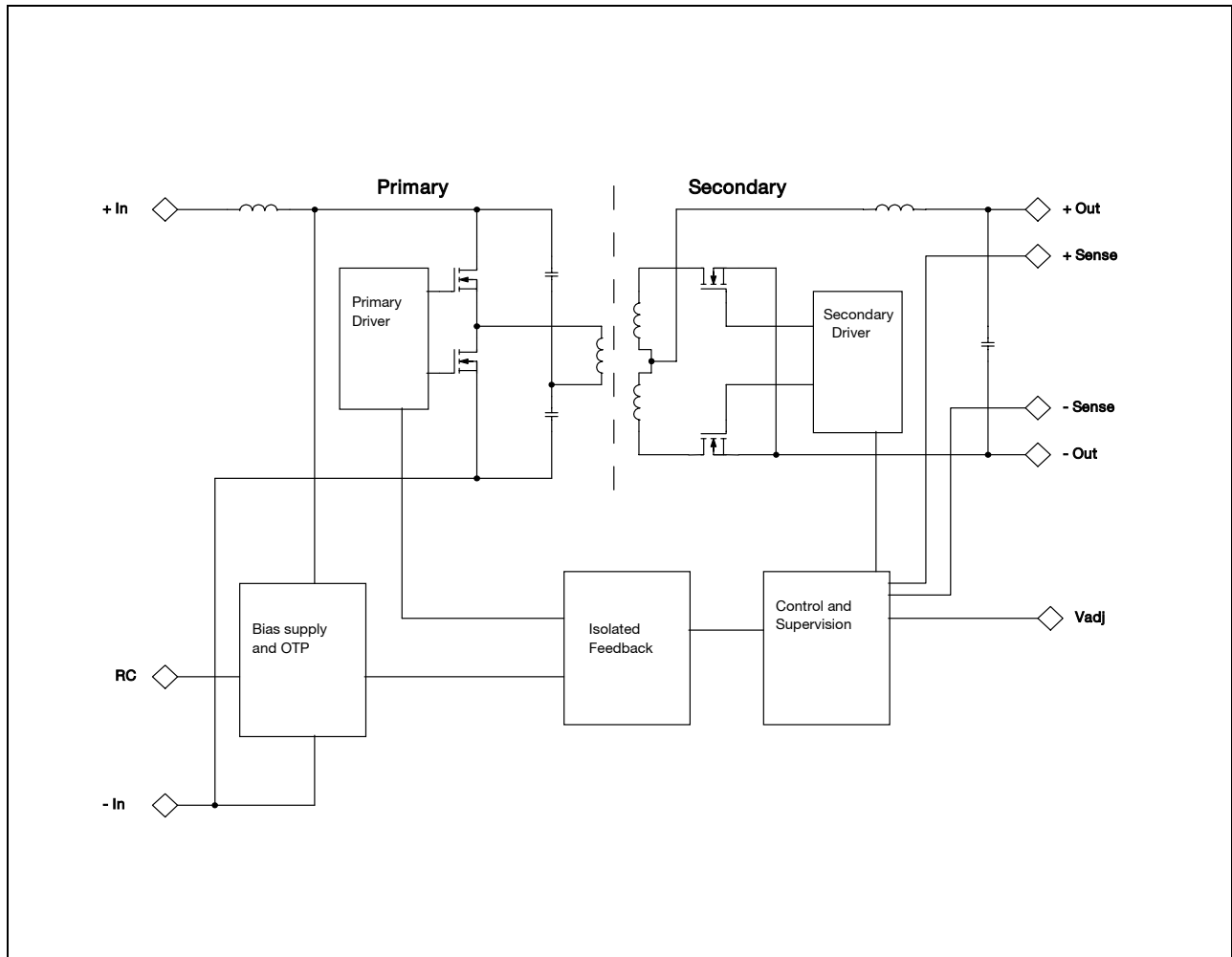

<b>PKB 4513 Direct Converters</b> Input 48 V, Output 4 A / 48 W	EN/LZT 146 407 R2A February 2010
	© Ericsson AB

**12V, 4A /48W Electrical Specification**

**PKB 4513 PINBLC**

$T_{P1} = -40$  to  $+95^{\circ}\text{C}$ ,  $V_I = 36$  to  $60$  V, unless otherwise specified under Conditions.  
 Typical values given at:  $T_{P1} = +25^{\circ}\text{C}$ ,  $V_I = 48$  V,  $I_O = \text{max}$ , unless otherwise specified under Conditions.  
 See Operating Information section for selection of capacitor types.

Characteristics		Conditions	min	typ	max	Unit
$V_I$	Input voltage range		36		60	V
$V_{Ioff}$	Turn-off input voltage	Decreasing input voltage	30	31	33	V
$V_{Ion}$	Turn-on input voltage	Increasing input voltage	33.5	34	34.5	V
Hyst	Input turn-on/off hysteresis		2.0	3		V
$C_I$	Internal input capacitance			3.35		$\mu\text{F}$
$P_O$	Output power		0		48	W
$\eta$	Efficiency	50 % of max $I_O$		89		%
		max $I_O$		91.8		
		50 % of max $I_O$ , $V_I = 53$ V		88.3		
		max $I_O$ , $V_I = 53$ V		91.5		
$P_d$	Power Dissipation	max $I_O$		4.3	5.7	W
$P_{II}$	Input idling power	$I_O = 0$ A, $V_I = 48$ V		2.3		W
$P_{RC}$	Input standby power	$V_I = 48$ V (turned off with RC)		0.1		W
$f_s$	Switching frequency	10-100 % of max $I_O$	230	250	270	kHz

$V_{OI}$	Output voltage initial setting and accuracy	$T_{P1} = +25^{\circ}\text{C}$ , $V_I = 48$ V, $I_O = 4$ A	11.8	12.0	12.25	V
$V_O$	Output voltage tolerance band	10-100 % of max $I_O$	11.58		12.42	V
	Idling voltage	$I_O = 0$ A	11.58		12.42	V
	Line regulation	max $I_O$		0.6	3	mV
	Load regulation	$V_I = 48$ V, 10-100 % of max $I_O$		0.8	4	mV
	Temperature regulation			50	200	mV
$V_{tr}$	Load transient voltage deviation	$V_I = 48$ V, Load step 25-75-25 % of max $I_O$ , $di/dt = 0.1$ A/ $\mu\text{s}$ see Note 1		$\pm 130$	$\pm 200$	mV
$t_{tr}$	Load transient recovery time			40	60	$\mu\text{s}$
$t_r$	Ramp-up time (from 10-90 % of $V_{OI}$ )	10-100 % of max $I_O$	8	13	19	ms
$t_s$	Start-up time (from $V_I$ connection to 90 % of $V_{OI}$ )		10	20	40	ms
$t_f$	$V_I$ shut-down fall time (from $V_I$ off to 10 % of $V_O$ )	max $I_O$		0.3		ms
		$I_O = 0.4$ A		3		ms
$t_{RC}$	RC start-up time	max $I_O$	10	20	30	ms
	RC shut-down fall time (from RC off to 10 % of $V_O$ )	max $I_O$		0.3		ms
		$I_O = 0.4$ A		2.8		ms
$I_O$	Output current		0.4		4	A
$I_{lim}$	Current limit threshold	$T_{P1} < \text{max } T_{P1}$	4.9	6.3	7.4	A
$I_{sc}$	Short circuit current	$T_{P1} = 25^{\circ}\text{C}$ , see Note 2		9.3	10	A
$C_{out}$	Recommended Capacitive Load	$T_{P1} = 25^{\circ}\text{C}$ ,	0		3000	$\mu\text{F}$
$V_{Oac}$	Output ripple & noise	See ripple & noise section, max $I_O$ , $V_{OI}$		14	50	mVp-p

Note 1: Cout used at load transient test is 470uF low-ESR capacitor.

Note 2: See Operating Information section.

**PKB 4513 Direct Converters**  
 Input 48 V, Output 4 A / 48 W

EN/LZT 146 407 R2A February 2010  
 © Ericsson AB

**12V, 4A /48W Typical Characteristics**

**PKB 4513 PINBLC**

**Efficiency**

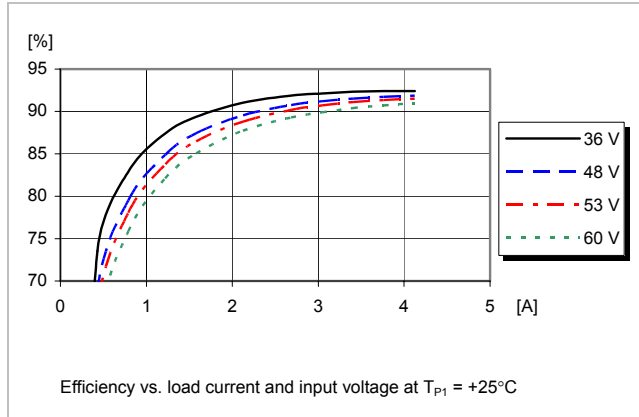

**Power Dissipation**

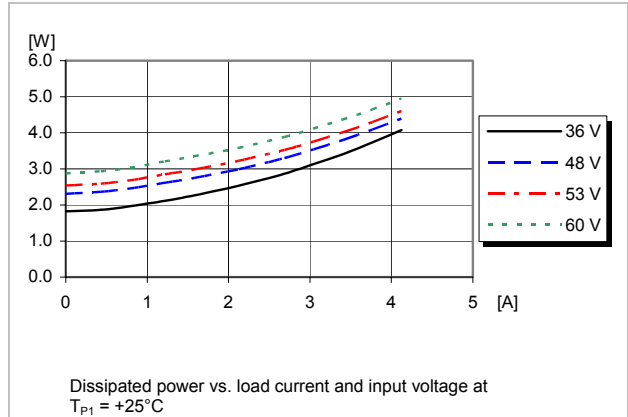

**Output Characteristics**

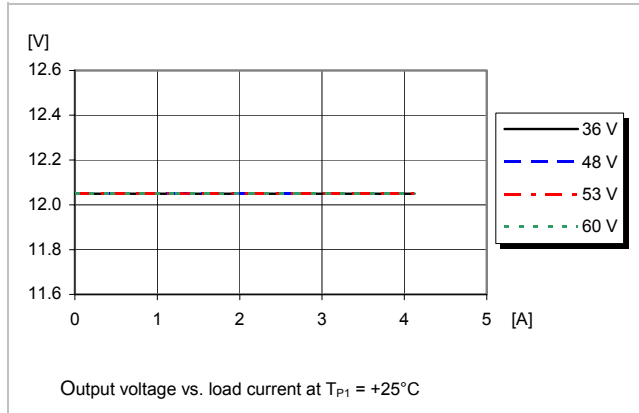

**Current Limit Characteristics**

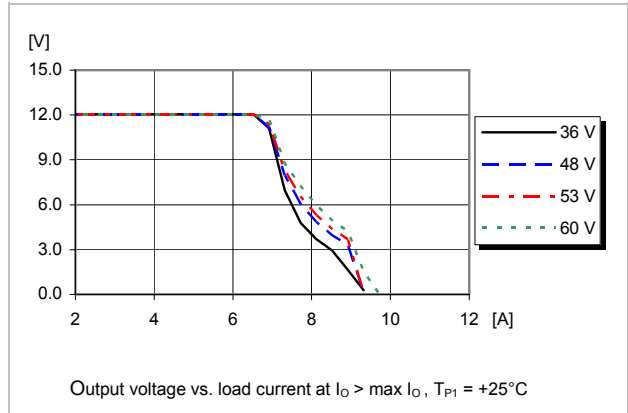

**PKB 4513 Direct Converters**  
 Input 48 V, Output 4 A / 48 W

EN/LZT 146 407 R2A February 2010

© Ericsson AB

**12V, 4A /48W Typical Characteristics**

**PKB 4513 PINBLC**

**Start-up**

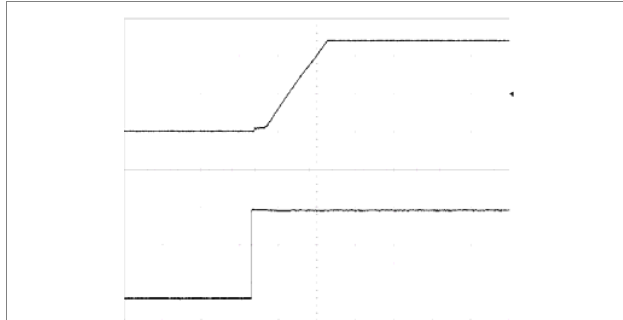

Start-up enabled by connecting  $V_i$  at:  
 $T_{P1} = +25^{\circ}\text{C}$ ,  $V_i = 48\text{ V}$ ,  
 $I_o = 4\text{ A}$  resistive load.

Top trace: output voltage (5 V/div.).  
 Bottom trace: input voltage (20 V/div.).  
 Time scale: (10 ms/div.).

**Shut-down**

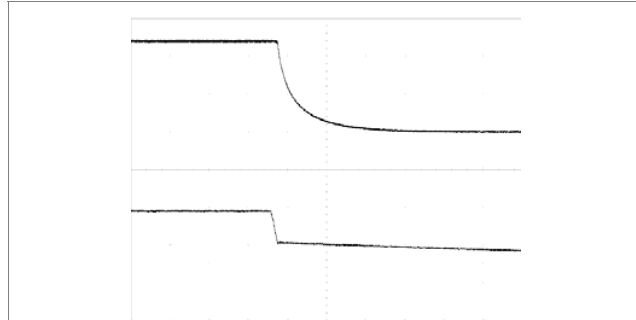

Shut-down enabled by disconnecting  $V_i$  at:  
 $T_{P1} = +25^{\circ}\text{C}$ ,  $V_i = 48\text{ V}$ ,  
 $I_o = 4\text{ A}$  resistive load.

Top trace: output voltage (5 V/div.).  
 Bottom trace: input voltage (20 V/div.).  
 Time scale: (0.2 ms/div.).

**Output Ripple & Noise**

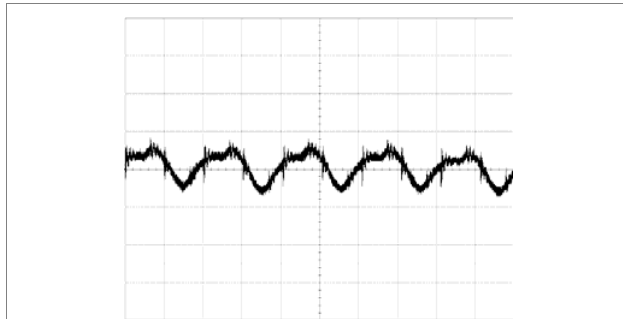

Output voltage ripple at:  
 $T_{P1} = +25^{\circ}\text{C}$ ,  $V_i = 48\text{ V}$ ,  
 $I_o = 4\text{ A}$  resistive load.

Trace: output voltage (10 mV/div.).  
 Time scale: (2  $\mu\text{s}$ /div.).

**Output Load Transient Response**

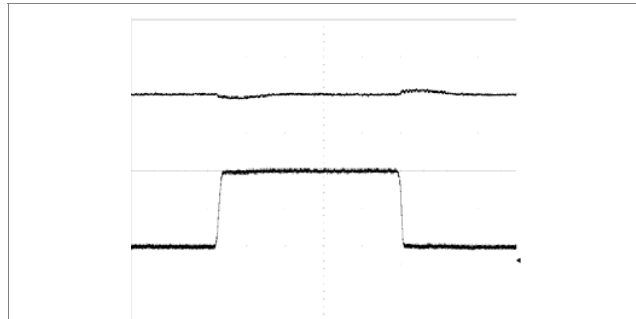

Output voltage response to load current step-change (1-3-1 A) at:  
 $T_{P1} = +25^{\circ}\text{C}$ ,  $V_i = 48\text{ V}$ .  $C_{out} = 470\mu\text{F}$

Top trace: output voltage (1 V /div.).  
 Bottom trace: load current (1 A/div.).  
 Time scale: (0.1 ms/div.).

**PKB 4513 Direct Converters**  
 Input 48 V, Output 4 A / 48 W

EN/LZT 146 407 R2A February 2010

© Ericsson AB

**12V, 4A /48W Typical Characteristics**

**PKB 4513 PINBLC**

**Output Current Derating – Open frame**

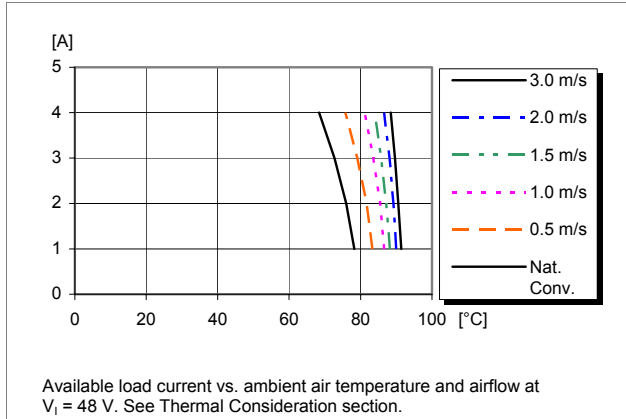



<b>PKB 4513 Direct Converters</b> Input 48 V, Output 4 A / 48 W	EN/LZT 146 407 R2A February 2010
	© Ericsson AB

**12V, 4A /48W Electrical Specification**

**PKB 4513 PINBOVLC**

$T_{P1} = -40$  to  $+95^{\circ}\text{C}$ ,  $V_I = 30$  to  $60$  V, unless otherwise specified under Conditions.  
 Typical values given at:  $T_{P1} = +25^{\circ}\text{C}$ ,  $V_I = 48$  V,  $I_O = \text{max}$ , unless otherwise specified under Conditions.  
 See Operating Information section for selection of capacitor types.

Characteristics		Conditions	min	typ	max	Unit
$V_I$	Input voltage range		30		60	V
$V_{loff}$	Turn-off input voltage	Decreasing input voltage	24.8	25.8	26.8	V
$V_{lon}$	Turn-on input voltage	Increasing input voltage	28	28.5	29	V
Hyst	Input turn-on/off hysteresis		2.0	3		V
$C_I$	Internal input capacitance			3.35		$\mu\text{F}$
$P_O$	Output power		0		48	W
$\eta$	Efficiency	50 % of max $I_O$		87.9		%
		max $I_O$		91.0		
		50 % of max $I_O$ , $V_I = 53$ V		87		
		max $I_O$ , $V_I = 53$ V		90.4		
$P_d$	Power Dissipation	max $I_O$		4.8	6.5	W
$P_{ii}$	Input idling power	$I_O = 0$ A, $V_I = 48$ V		2.6		W
$P_{RC}$	Input standby power	$V_I = 48$ V (turned off with RC)		0.1		W
$f_s$	Switching frequency	10-100 % of max $I_O$	230	250	270	kHz

$V_{O1}$	Output voltage initial setting and accuracy	$T_{P1} = +25^{\circ}\text{C}$ , $V_I = 48$ V, $I_O = 4$ A	11.8	12.0	12.25	V
$V_O$	Output voltage tolerance band	10-100 % of max $I_O$	11.58		12.42	V
	Idling voltage	$I_O = 0$ A	11.58		12.42	V
	Line regulation	max $I_O$		3	6	mV
	Load regulation	$V_I = 48$ V, 10-100 % of max $I_O$		1	6	mV
	Temperature regulation			50	200	mV
$V_{tr}$	Load transient voltage deviation	$V_I = 48$ V, Load step 25-75-25 % of max $I_O$ , $di/dt = 0.1$ A/ $\mu\text{s}$ see Note 1		$\pm 160$	$\pm 250$	mV
$t_{tr}$	Load transient recovery time			100		$\mu\text{s}$
$t_r$	Ramp-up time (from 10-90 % of $V_{O1}$ )	10-100 % of max $I_O$	10	14	20	ms
$t_s$	Start-up time (from $V_I$ connection to 90 % of $V_{O1}$ )		15	22	31	ms
$t_f$	$V_I$ shut-down fall time (from $V_I$ off to 10 % of $V_O$ )	max $I_O$		0.3		ms
		$I_O = 0.4$ A		3		ms
$t_{RC}$	RC start-up time	max $I_O$		18		ms
	RC shut-down fall time (from RC off to 10 % of $V_O$ )	max $I_O$		0.3		ms
		$I_O = 0.4$ A		2.6		ms
$I_O$	Output current		0.4		4	A
$I_{lim}$	Current limit threshold	$T_{P1} < \text{max } T_{P1}$	4.6	5.2	7.4	A
$I_{sc}$	Short circuit current	$T_{P1} = 25^{\circ}\text{C}$ , see Note 2		7.3	8	A
$C_{out}$	Recommended Capacitive Load	$T_{P1} = 25^{\circ}\text{C}$ ,	0		3000	$\mu\text{F}$
$V_{Oac}$	Output ripple & noise	See ripple & noise section, max $I_O$ , $V_{O1}$		24	50	mVp-p

Note 1: Cout used at load transient test is 470uF low-ESR capacitor.

Note 2: See Operating Information section.

**PKB 4513 Direct Converters**  
 Input 48 V, Output 4 A / 48 W

EN/LZT 146 407 R2A February 2010  
 © Ericsson AB

**12V, 4A /48W Typical Characteristics**

**PKB 4513 PINBOVLC**

**Efficiency**

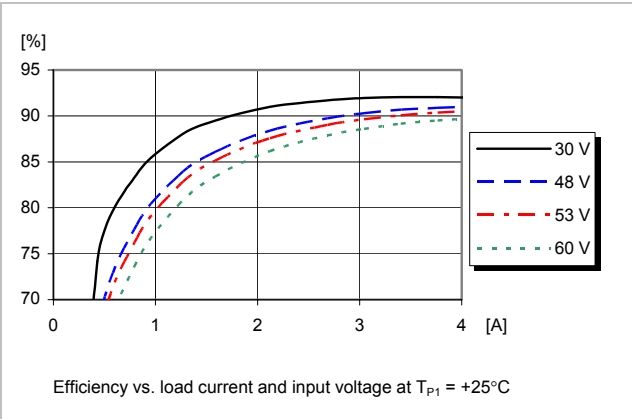

**Power Dissipation**

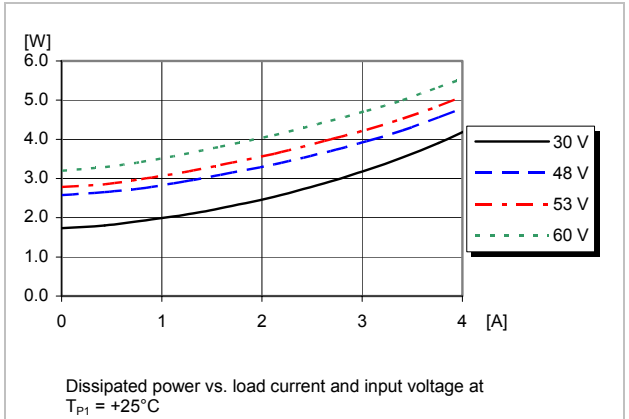

**Output Characteristics**

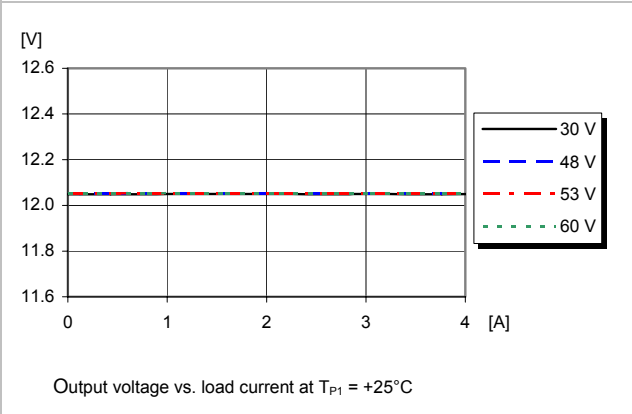

**Current Limit Characteristics**

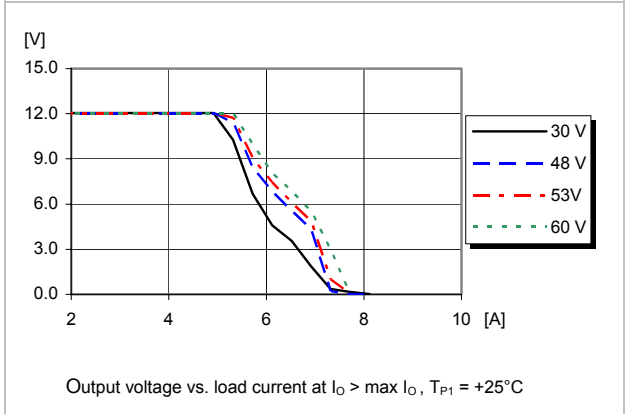

**PKB 4513 Direct Converters**  
 Input 48 V, Output 4 A / 48 W

EN/LZT 146 407 R2A February 2010  
 © Ericsson AB

**12V, 4A /48W Typical Characteristics**

**PKB 4513 PINBOVLC**

**Start-up**

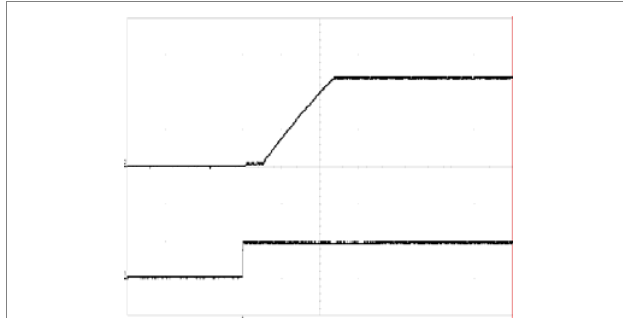

Start-up enabled by connecting  $V_I$  at:  
 $T_{P1} = +25^{\circ}\text{C}$ ,  $V_I = 48\text{ V}$ ,  
 $I_O = 4\text{ A}$  resistive load.  
 Top trace: output voltage (5 V/div.).  
 Bottom trace: input voltage (50 V/div.).  
 Time scale: (10 ms/div.).

**Shut-down**

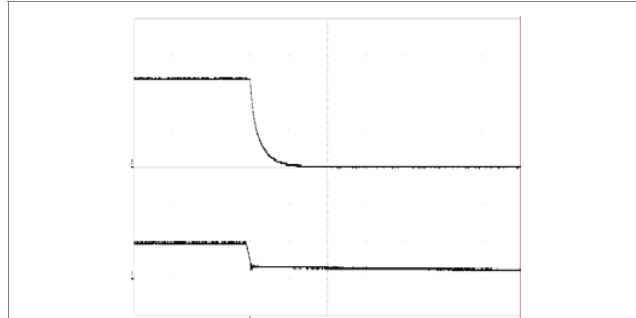

Shut-down enabled by disconnecting  $V_I$  at:  
 $T_{P1} = +25^{\circ}\text{C}$ ,  $V_I = 48\text{ V}$ ,  
 $I_O = 4\text{ A}$  resistive load.  
 Top trace: output voltage (5 V/div.).  
 Bottom trace: input voltage 50 V/div.).  
 Time scale: (0.5 ms/div.).

**Output Ripple & Noise**

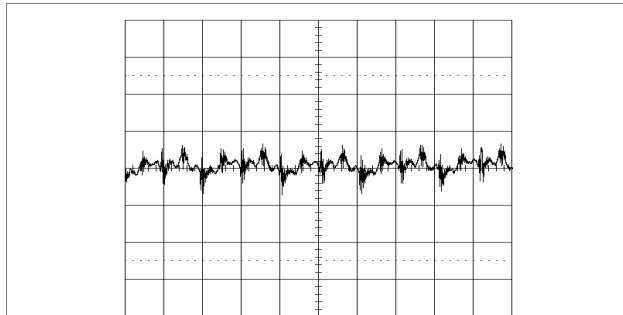

Output voltage ripple at:  
 $T_{P1} = +25^{\circ}\text{C}$ ,  $V_I = 48\text{ V}$ ,  
 $I_O = 4\text{ A}$  resistive load.  
 Trace: output voltage (20 mV/div.).  
 Time scale: (2 μs/div.).

**Output Load Transient Response**

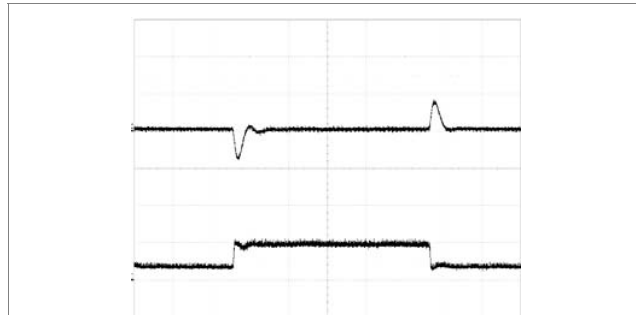

Output voltage response to load current step-  
 change (1-3-1 A) at:  
 $T_{P1} = +25^{\circ}\text{C}$ ,  $V_I = 48\text{ V}$ ,  $C_{out} = 470\mu\text{F}$   
 Top trace: output voltage (200mV /div.).  
 Bottom trace: load current (3 A/div.).  
 Time scale: (0.2 ms/div.).

**PKB 4513 Direct Converters**  
 Input 48 V, Output 4 A / 48 W

EN/LZT 146 407 R2A February 2010  
 © Ericsson AB

**12V, 4A /48W Typical Characteristics**

**PKB 4513 PINBOVLC**

**Output Current Derating – Open frame**

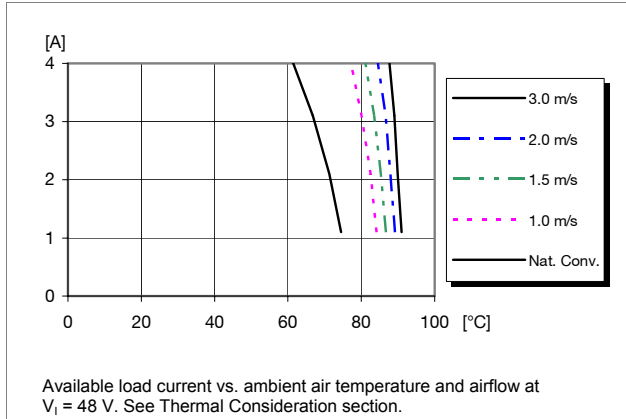

<p><b>PKB 4513 Direct Converters</b> Input 48 V, Output 4 A / 48 W</p>	<p>EN/LZT 146 407 R2A February 2010 © Ericsson AB</p>
--	---

**EMC Specification**

Conducted EMI measured according to EN55022, CISPR 22 and FCC part 15J (see test set-up). See Design Note 009 for further information. The fundamental switching frequency is 250 kHz @  $V_1 = 48\text{ V}$ , max  $I_o$ .

**Conducted EMI Input terminal value (typ)**

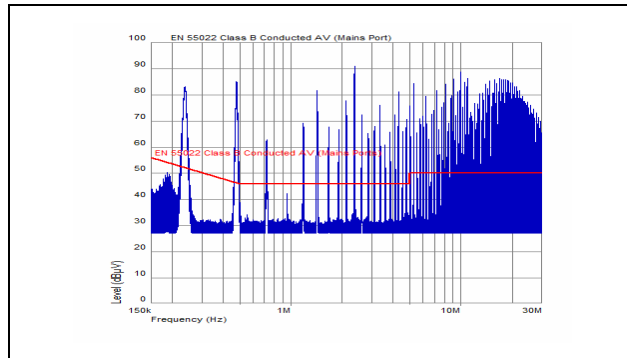

EMI without filter (PKB 4513 PINBOVLC)

**External filter (class B)**

Required external input filter in order to meet class B in EN 55022, CISPR 22 and FCC part 15J.

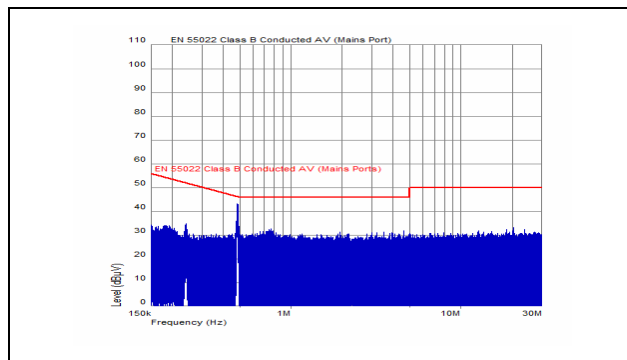
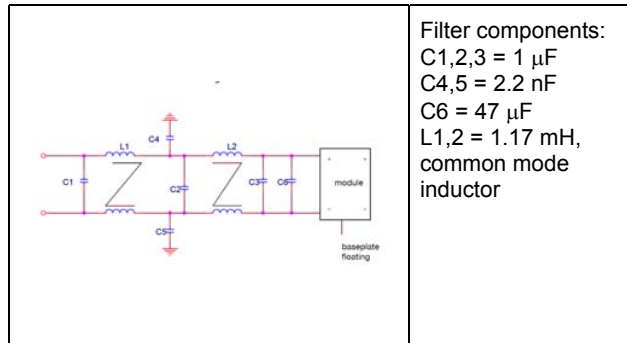

EMI with filter (PKB 4513 PINBOVLC)

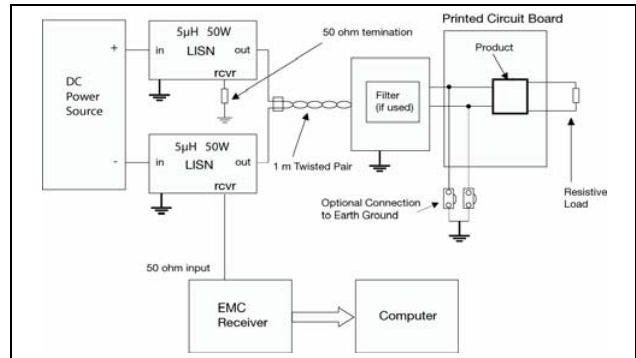

Test set-up

**Layout recommendations**

The radiated EMI performance of the Product will depend on the PCB layout and ground layer design. It is also important to consider the stand-off of the product. If a ground layer is used, it should be connected to the output of the product and the equipment ground or chassis.

A ground layer will increase the stray capacitance in the PCB and improve the high frequency EMC performance.

**Output ripple and noise**

Output ripple and noise measured according to figure below. See Design Note 022 for detailed information.

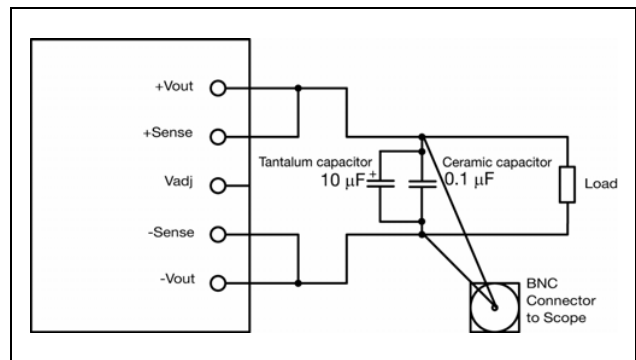

Output ripple and noise test setup

**PKB 4513 Direct Converters**  
Input 48 V, Output 4 A / 48 W

EN/LZT 146 407 R2A February 2010

© Ericsson AB

## Operating information

### Input Voltage

The input voltage range 36 to 60Vdc meets the requirements of the European Telecom Standard ETS 300 132-2 for normal input voltage range in-48 Vdc systems. At input voltages exceeding 60 V, the power loss will be higher than at normal input voltage and  $T_{P1}$  must be limited to absolute max +120°C. The absolute maximum continuous input voltage is 80 Vdc.

### Turn-off Input Voltage

The DC/DC converters monitor the input voltage and will turn on and turn off at predetermined levels. The minimum hysteresis between turn on and turn off input voltage is 2V.

### Remote Control (RC)

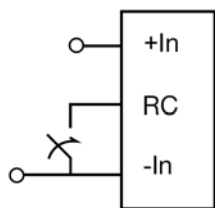

The products are fitted with a remote control function referenced to the primary negative input connection (- In), with negative and positive logic options available. The RC function allows the converter to be turned on/off by an external device like a semiconductor or mechanical switch.

The maximum required sink current is 1 mA. When the RC pin is left open, the voltage generated on the RC pin is 6 V. The second option is "positive logic" remote control, which can be ordered by adding the suffix "P" to the end of the part number. The converter will turn on when the input voltage is applied with the RC pin open. Turn off is achieved by connecting the RC pin to the - In. To ensure safe turn off the voltage difference between RC pin and the - In pin shall be less than 1V. The converter will restart automatically when this connection is opened.

See Design Note 021 for detailed information.

### Input and Output Impedance

The impedance of both the input source and the load will interact with the impedance of the DC/DC converter. It is important that the input source has low characteristic impedance. The converters are designed for stable operation without external capacitors connected to the input or output. The performance in some applications can be enhanced by addition of external capacitance as described under External Decoupling Capacitors. If the input voltage source contains significant inductance, the addition of a 100  $\mu$ F capacitor across the input of the converter will ensure stable operation. The capacitor is not required when powering the DC/DC converter from an input source with an inductance below 10  $\mu$ H.

### External Decoupling Capacitors

When powering loads with significant dynamic current requirements, the voltage regulation at the point of load can be improved by addition of decoupling capacitors at the load. The most effective technique is to locate low ESR ceramic and electrolytic capacitors as close to the load as possible, using several parallel capacitors to lower the effective ESR. The ceramic capacitors will handle high-frequency dynamic load changes while the electrolytic capacitors are used to handle low frequency dynamic load changes. Ceramic capacitors will also reduce any high frequency noise at the load.

It is equally important to use low resistance and low inductance PCB layouts and cabling. External decoupling capacitors will become part of the control loop of the DC/DC converter and may affect the stability margins. An 470uF lower ESR capacitor should be added at output to get the load transient performance specified in the datasheet. The module can work with 0-3000uF low ESR capacitor at output in 25°C and 95°C, but it can only handle 0-1000uF low ESR capacitor at output in -40°C. The ESR of the capacitors is a very important parameter. Power Modules guarantee stable operation with a verified ESR value of >10 m $\Omega$  across the output connections. For further information please contact your local Ericsson Power Modules representative.

### Parallel Operation

Two converters may be paralleled for redundancy if the total power is equal or less than  $P_O$  max. It is not recommended to parallel the converters without using external current sharing circuits.

See Design Note 006 for detailed information.

### Over Temperature Protection (OTP)

The converters are protected from thermal overload by the control IC.

When  $T_{P1}$  as defined in thermal consideration section exceeds 135°C the converter will shut down. The DC/DC converter will make continuous attempts to start up (non-latching mode) and resume normal operation automatically when the temperature has dropped about 15°C below the temperature threshold.

### Over Current Protection (OCP)

The converters include current limiting circuitry for protection at continuous overload.

The output voltage will decrease towards zero for output currents in excess of max output current (max  $I_o$ ). The converter will resume normal operation after removal of the overload. The load distribution should be designed for the maximum output short circuit current specified.

<b>PKB 4513 Direct Converters</b> Input 48 V, Output 4 A / 48 W	EN/LZT 146 407 R2A February 2010
	© Ericsson AB

**Thermal Consideration**

**General**

The converters are designed to operate in different thermal environments and sufficient cooling must be provided to ensure reliable operation.

Cooling is achieved mainly by conduction, from the pins to the host board, and convection, which is dependant on the airflow across the converter. Increased airflow enhances the cooling of the converter.

The Output Current Derating graph found in the Output section for each model provides the available output current vs. ambient air temperature and air velocity at  $V_{in} = 48 V$ .

The DC/DC converter is tested on a 254 x 254 mm, 35  $\mu m$  (1 oz), 8-layer test board mounted vertically in a wind tunnel with a cross-section of 305 x 305 mm.

Proper cooling of the DC/DC converter can be verified by measuring the temperature at positions P1, P2, P3, P4, P5 and P6. The temperature at these positions should not exceed the max values provided in the table below.

Note that the max value is the absolute maximum rating (non destruction) and that the electrical Output data is guaranteed up to  $T_{P1} = +95^{\circ}C$ .

See Design Note 019 for further information.

**Connections**

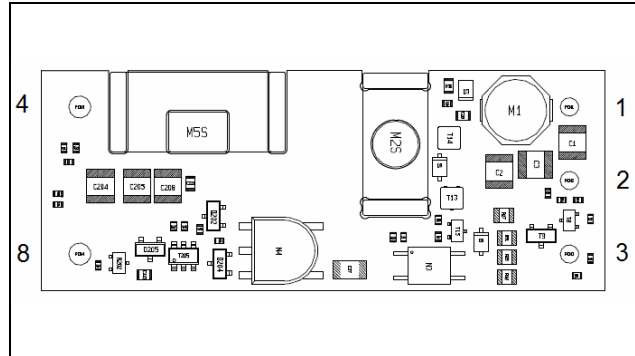

Pin	Designation	Function
1	+In	Positive input
2	RC	Remote control
3	-In	Negative input
4	+Out	Positive output
8	-Out	Negative output

Position	Description	Temp. limit
P1	Reference Point, PCB	110°C
P2	MOSFET, T203	120°C
P3	MOSFET, T202	120°C
P4	IC, N1	120°C
P5	Optocoupler, N3	95°C
P6	Ferrite core, M2	130°C

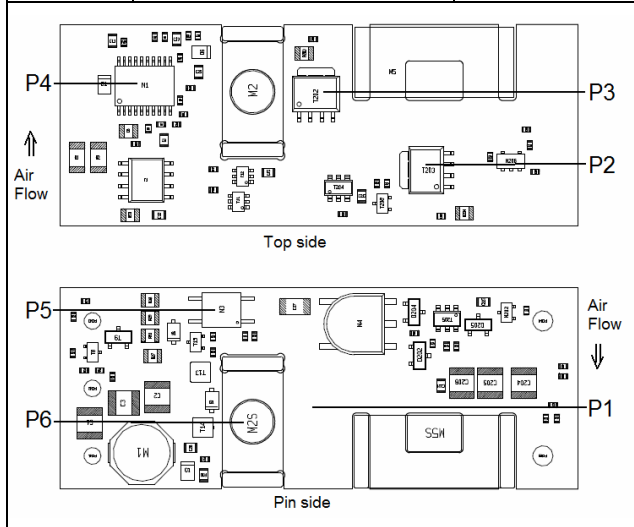

**PKB 4513 Direct Converters**  
 Input 48 V, Output 4 A / 48 W

EN/LZT 146 407 R2A February 2010

© Ericsson AB

**Mechanical Information- Through hole mount version**

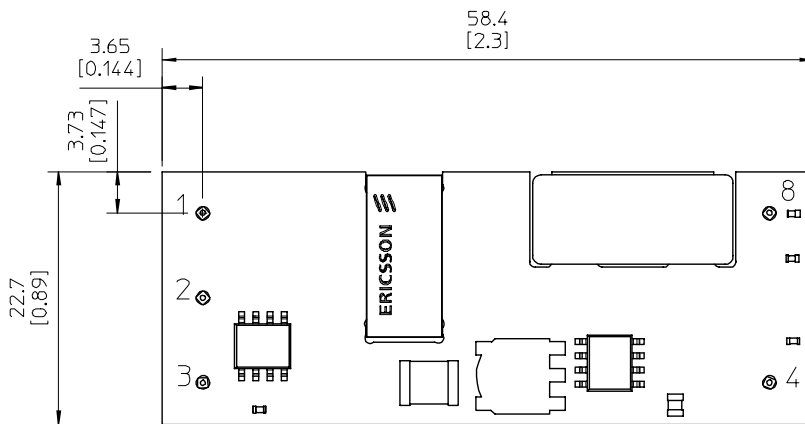
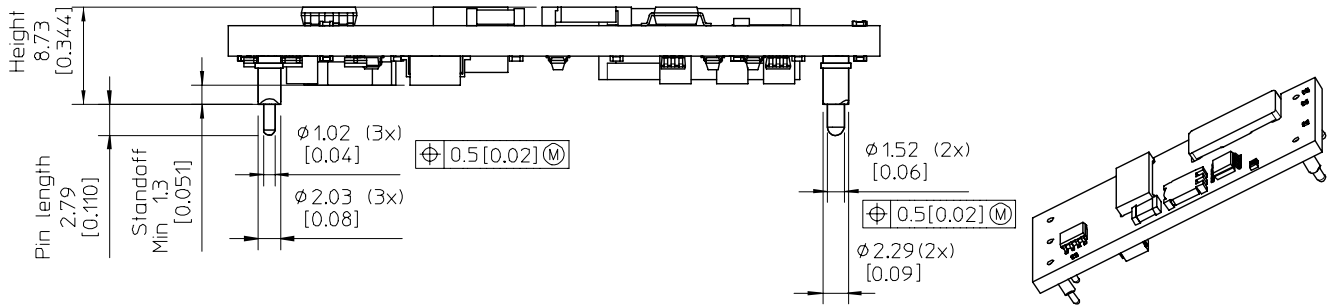

RECOMMENDED FOOTPRINT

TOP VIEW

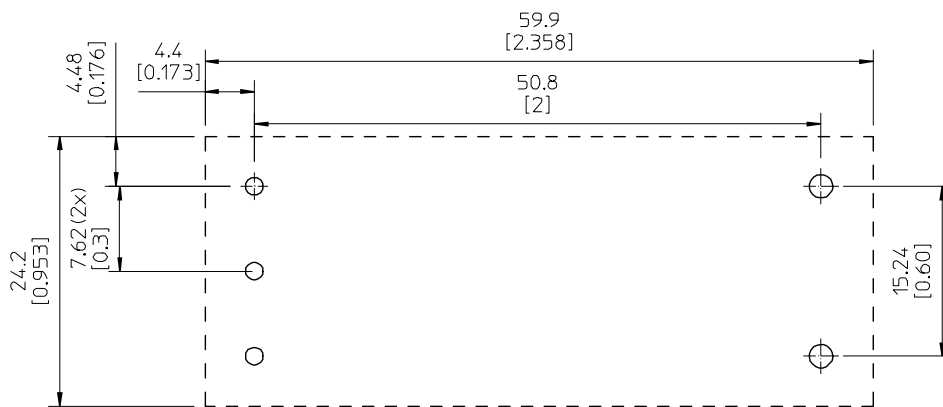

Pins:  
 Material, pins 1-3: Brass  
 Material, pins 4,8: copper alloy  
 Plating: 0.1  $\mu$ m Au over 2  $\mu$ m Ni

Weight: typical 21 g

 All dimensions in mm[inch].



**PKB 4513 Direct Converters**  
 Input 48 V, Output 4 A / 48 W

EN/LZT 146 407 R2A February 2010

© Ericsson AB

**Soldering Information – Through Hole Mounting**

The product is intended for manual or wave soldering. When wave soldering is used, the temperature on the pins is specified to maximum 270°C for maximum 10 seconds.

A maximum preheat rate of 4°C/s and a temperature of max +150°C is suggested. When soldering by hand, care should be taken to avoid direct contact between the hot soldering iron tip and the pins for more than a few seconds in order to prevent overheating.

A no-clean flux is recommended to avoid entrapment of cleaning fluids in cavities inside the product or between the product and the host board. The cleaning residues may affect long time reliability and isolation voltage.

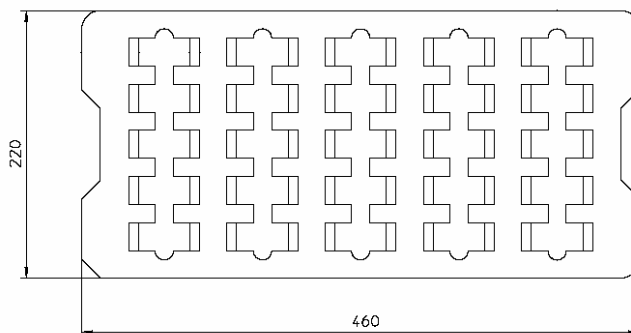

**Delivery Package Information**

The products are delivered in antistatic foams.

Tray Specifications	
<b>Material</b>	Antistatic PE foam
<b>Surface resistance</b>	$10^5 < \text{Ohm/square} < 10^{12}$
<b>Bakability</b>	The trays are not bakable
<b>Tray capacity</b>	25 products/tray
<b>Tray thickness</b>	18 mm [0.709 inch]
<b>Box capacity</b>	100 products (4 full trays/box)
<b>Tray weight</b>	45 g empty, 570 g full tray

## Technical Specification

<b>PKB 4513 Direct Converters</b> Input 48 V, Output 4 A / 48 W	EN/LZT 146 407 R2A February 2010
	© Ericsson AB

**Product Qualification Specification**

Characteristics			
External visual inspection	IPC-A-610		
Change of temperature (Temperature cycling)	IEC 60068-2-14 Na	Temperature range Number of cycles Dwell/transfer time	-40 to +100°C 1000 15 min/0-1 min
Cold (in operation)	IEC 60068-2-1 Ad	Temperature T <sub>A</sub> Duration	-45°C 72 h
Damp heat	IEC 60068-2-67 Cy	Temperature Humidity Duration	+85°C 85 % RH 1000 hours
Dry heat	IEC 60068-2-2 Bd	Temperature Duration	+125°C 1000 h
Electrostatic discharge susceptibility	IEC 61340-3-1, JESD 22-A114 IEC 61340-3-2, JESD 22-A115	Human body model (HBM) Machine Model (MM)	Class 2, 2000 V Class 3, 200 V
Immersion in cleaning solvents	IEC 60068-2-45 XA Method 2	Water Glycol ether Isopropyl alcohol	+55°C +35°C +35°C
Mechanical shock	IEC 60068-2-27 Ea	Peak acceleration Duration	100 g 6 ms
Operational life test	MIL-STD-202G method 108A	Duration	1000 h
Resistance to soldering heat	IEC 60068-2-20 Tb Method 1A	Solder temperature Duration	270°C 10-13 s
Robustness of terminations	IEC 60068-2-21 Test Ua1	Through hole mount products	All leads
Solderability	IEC 60068-2-20 test Ta <sup>2</sup>	Preconditioning Temperature, SnPb Eutectic Temperature, Pb-free	Steam ageing 235°C 245°C
Vibration, broad band random	IEC 60068-2-64 Fh, method 1	Frequency Spectral density Duration	10 to 500 Hz 0.07 g <sup>2</sup> /Hz 10 min in each perpendicular direction