

NOT INTENDED FOR RETAIL TRADE

## EVEREADY NO. EV135

**C**



Industry Standard Dimensions in mm (inches)

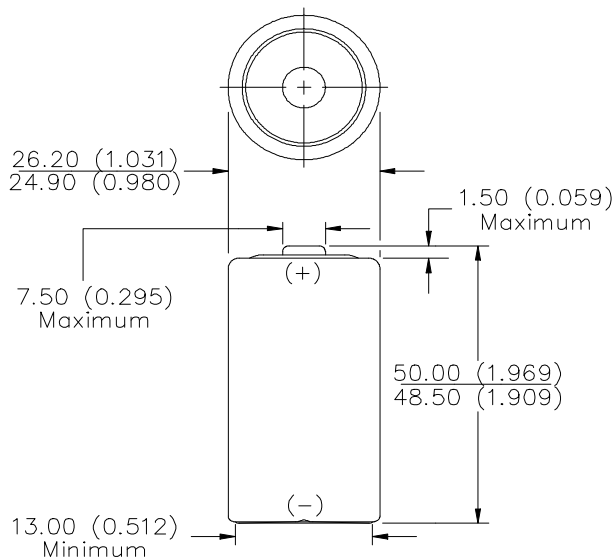

**Chemical System:** *INDUSTRIAL SUPER HEAVY DUTY*  
 Zinc-Manganese Dioxide (Zn/MnO<sub>2</sub>)  
 (No Added Mercury or Cadmium)

**Designation:** ANSI-14D, IEC-R14

**Battery Voltage:** 1.5 Volts

**Average Weight:** 48.7 grams (1.7 oz.)

**Volume:** 25 cubic centimeters (1.5 cubic inch)

**Average Capacity:** 3.0 Ah to 0.8 volts  
 (Rated at 25 mA continuous at 21°C)

**Cell:** One No.35 (size 'C')

**Jacket:** Metal

### ANSI Industry Standard Test @ 20°C

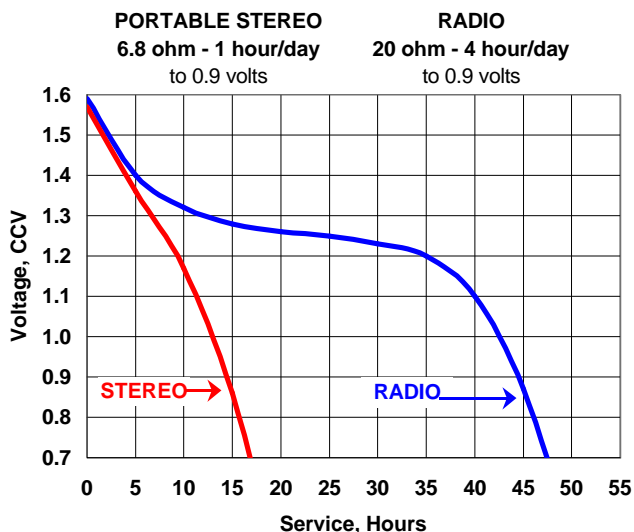

### ANSI Industry Standard Test @ 20°C

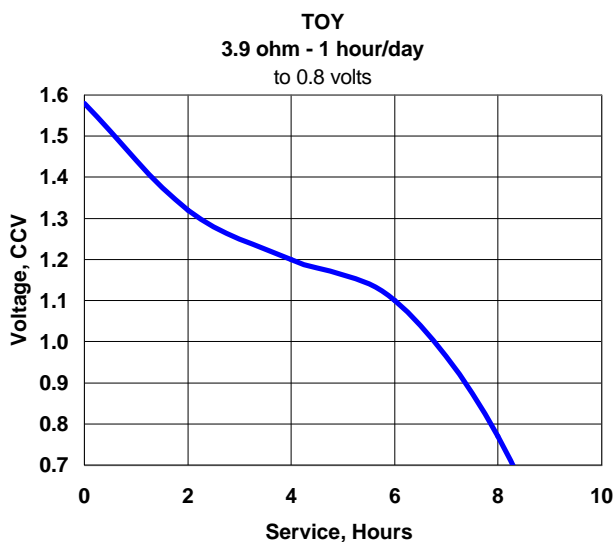

### ANSI Industry Standard Test @ 20°C

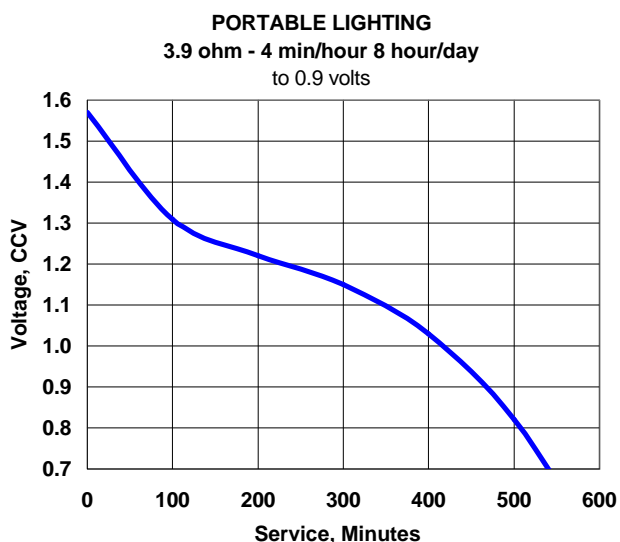

### Important Notice

This data sheet contains information specific to batteries manufactured at the time of its publication.

**Contents herein do not constitute a warranty.**

Copyright © Eveready Battery Co. - All rights reserved