

# SPECIFICATIONS

"Preliminary"



Model Number: DDE983948Z1E  
Part Number: 040991

April 11, 2007

## Mechanical Drawing:

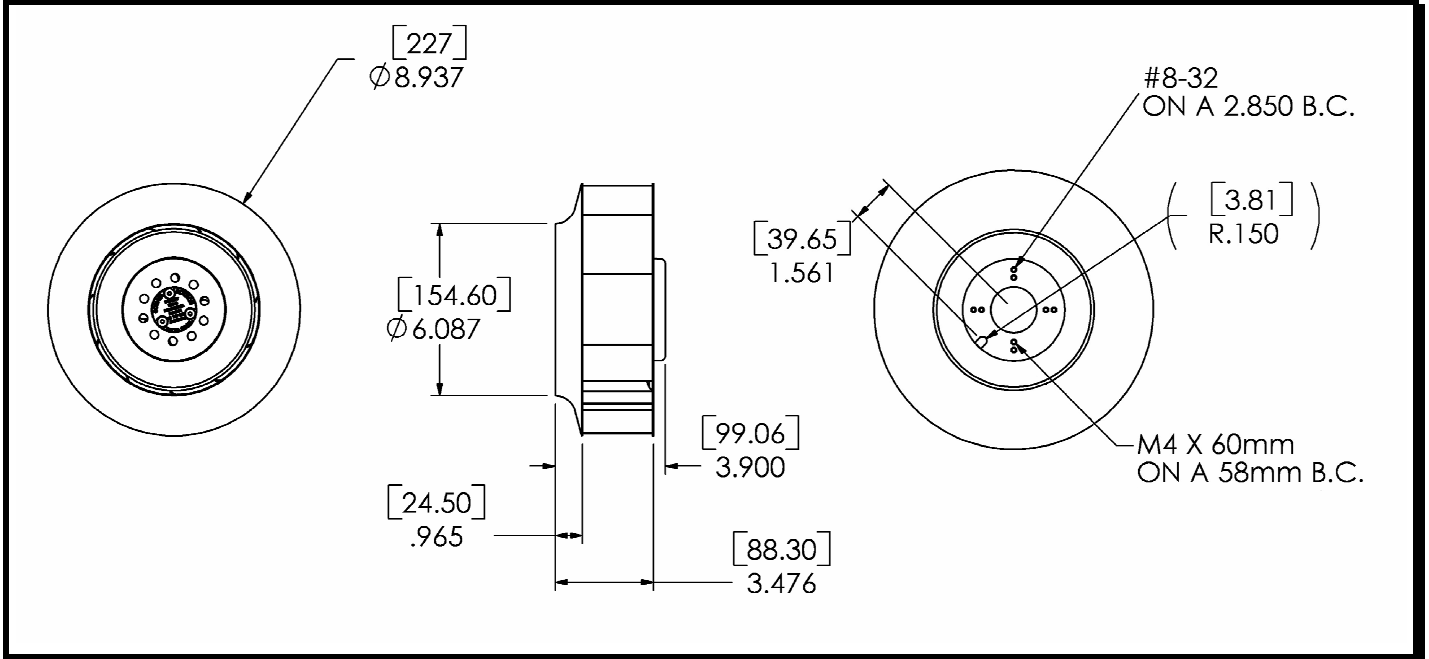

### Motor:

Nominal Voltage = 48 VDC  
Operating Voltage Range = 28 - 72 VDC  
Nominal Running Current = 4.7 amps  
Locked Rotor Current = TBD amps  
Running Power = 225 watts  
Average Speed = 3400 RPM  
Bearings = Ball  
Air Flow = 1005 CFM  
Static Pressure = 3.58 (in/H<sub>2</sub>O)  
Acoustic = TBD

### Construction:

Motor Base: Die Cast Aluminum  
Propeller: Sheet Metal, Galvanized

### Agency Approvals:

Pending

### Life Expectancy:

TBD

### Additional Features:

Brushless DC Motor  
Electronic Locked Rotor Protection  
Polarity Protected  
Automatic Restart Capability  
Operating Temperature: -10°C to 70°C  
Storage Temperature: -40°C to 85°C

### Tachometer Specifications:

Output: Open Collector  
I<sub>c</sub>: 20 mA. Max  
V<sub>cc</sub>: 72 VDC Max  
Pulses per Revolution: 2  
Isolated: No

### Termination:

12" Leadwires, 22 AWG, UL 1061  
Red - Power (+)  
Black - Return (-)  
Blue/White - Tachometer (Output)