

# Digital Thermometers and Thermostats with SPI/3-Wire Interface

## General Description

The MAX31722/MAX31723 digital thermometers and thermostats with an SPI™/3-wire interface provide temperature readings that indicate the device temperature. No additional components are required; the devices are truly temperature-to-digital converters. Temperature readings are communicated from the device over an SPI interface or a 3-wire serial interface. The choice of interface is selectable by the user. For applications that require greater temperature resolution, the user can adjust the readout resolution from 9 to 12 bits. This is particularly useful in applications where thermal runaway conditions must be detected quickly. The thermostat has a dedicated open-drain output (TOUT). Two thermostat operating modes, comparator and interrupt, control thermostat operation based on user-defined nonvolatile trip points (THIGH and TLOW). Both devices feature a 1.7V to 3.7V supply rail.

## Applications

Networking Equipment  
Cellular Base Stations  
Industrial Equipment  
Any Thermally Sensitive Systems

## Features

- ◆ Temperature Measurements Require No External Components
- ◆ Measures Temperatures from  $-55^{\circ}\text{C}$  to  $+125^{\circ}\text{C}$
- ◆ MAX31722 Thermometer Accuracy is  $\pm 2.0^{\circ}\text{C}$
- ◆ MAX31723 Thermometer Accuracy is  $\pm 0.5^{\circ}\text{C}$
- ◆ Thermometer Resolution is Configurable from 9 to 12 Bits ( $0.5^{\circ}\text{C}$  to  $0.0625^{\circ}\text{C}$  Resolution)
- ◆ Thermostat Output with User-Defined Nonvolatile Thresholds
- ◆ Data is Read from/Written to by SPI (Mode 0 and 2) or 3-Wire Serial Interface
- ◆ 1.7V to 3.7V Power-Supply Range
- ◆ Available in 8-Pin  $\mu\text{MAX}^{\circledR}$  Package

## Ordering Information

PART	TEMP RANGE	PIN-PACKAGE
MAX31722MUA+	$-55^{\circ}\text{C}$ to $+125^{\circ}\text{C}$	8 $\mu\text{MAX}$
MAX31722MUA+T	$-55^{\circ}\text{C}$ to $+125^{\circ}\text{C}$	8 $\mu\text{MAX}$
MAX31723MUA+	$-55^{\circ}\text{C}$ to $+125^{\circ}\text{C}$	8 $\mu\text{MAX}$
MAX31723MUA+T	$-55^{\circ}\text{C}$ to $+125^{\circ}\text{C}$	8 $\mu\text{MAX}$

+ Denotes a lead (Pb)-free/RoHS-compliant package.  
T = Tape and reel.

## Functional Diagram

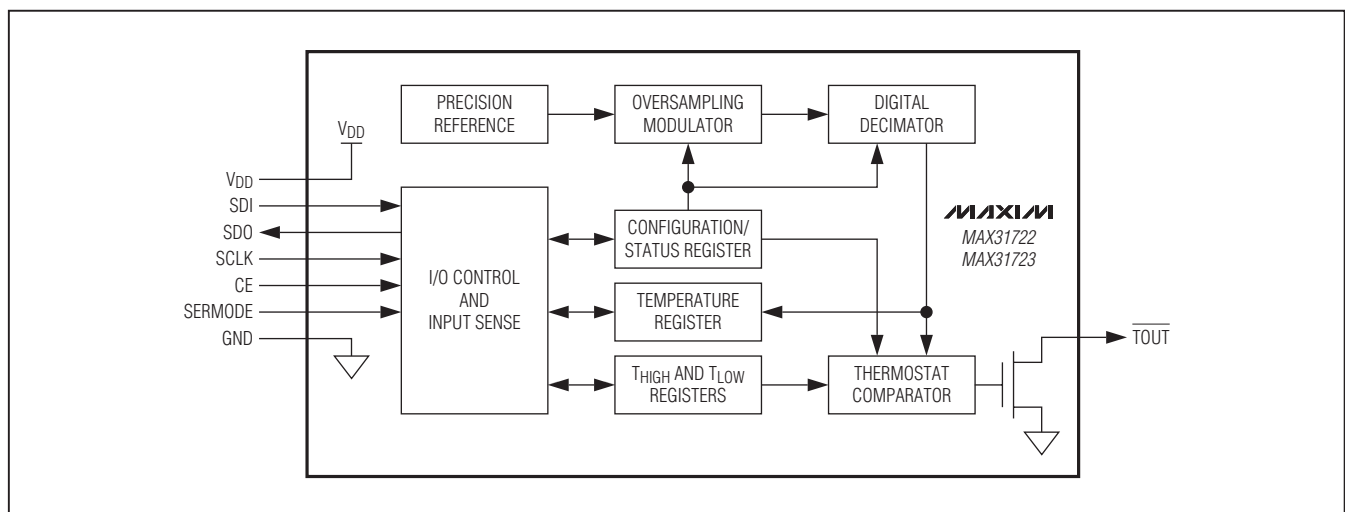

SPI is a trademark of Motorola, Inc.

$\mu\text{MAX}$  is a registered trademark of Maxim Integrated Products, Inc.

# Digital Thermometers and Thermostats with SPI/3-Wire Interface

## ABSOLUTE MAXIMUM RATINGS

Voltage Range on VDD Relative to GND.....-0.3V to +6.0V  
 Voltage Range on Any Other Pin Relative to GND...-0.3V to +6.0V  
 Continuous Power Dissipation (T<sub>A</sub> = +70°C)  
 μMAX (derate 4.5mW/°C above +70°C).....362mW  
 EEPROM Programming Temperature Range .....-40°C to +85°C

Operating Junction Temperature Range .....-55°C to +125°C  
 Storage Temperature Range.....-55°C to +125°C  
 Lead Temperature (soldering, 10s) .....+300°C  
 Soldering Temperature (reflow) .....+260°C

*Stresses beyond those listed under "Absolute Maximum Ratings" may cause permanent damage to the device. These are stress ratings only, and functional operation of the device at these or any other conditions beyond those indicated in the operational sections of the specifications is not implied. Exposure to absolute maximum rating conditions for extended periods may affect device reliability.*

## RECOMMENDED OPERATING CHARACTERISTICS

(T<sub>J</sub> = -55°C to +125°C, unless otherwise noted.)

PARAMETER	SYMBOL	CONDITIONS	MIN	TYP	MAX	UNITS
Supply Voltage	V <sub>DD</sub>	(Note 1)	1.7		3.7	V
Input Logic-High	V <sub>IH</sub>	(Note 1)	0.7 x V <sub>DD</sub>		V <sub>DD</sub> + 0.3	V
Input Logic-Low	V <sub>IL</sub>	(Note 1)	-0.3		0.3 x V <sub>DD</sub>	V

## DC ELECTRICAL CHARACTERISTICS

(V<sub>DD</sub> = 1.7V to 3.7V, T<sub>J</sub> = -55°C to +125°C, unless otherwise noted.)

PARAMETER	SYMBOL	CONDITIONS	MIN	TYP	MAX	UNITS
MAX31722 Thermometer Error	T <sub>ERR</sub>	-40°C to +85°C			±2.0	°C
		-55°C to +125°C			±3.0	
MAX31723 Thermometer Error	T <sub>ERR</sub>	0°C to +70°C			±0.5	°C
		-55°C to +125°C			±2.0	
Resolution			9		12	Bits
Conversion Time	t <sub>CONVT</sub>	9-bit conversions			25	ms
		10-bit conversions			50	
		11-bit conversions			100	
		12-bit conversions			200	
Logic 0 Output (SDO, $\overline{\text{TOU}}$ )	V <sub>OL</sub>	(Note 2)			0.4	V
Logic 1 Output (SDO)	V <sub>OH</sub>	(Note 3)	V <sub>DD</sub> - 0.4			V
Leakage Current	I <sub>L</sub>		-1		+1	μA
Active Current	I <sub>CC</sub>	Active temperature conversions (Note 4)			1150	μA
		Communication only			100	
		EEPROM writes (-40°C to +85°C)			1150	
		EEPROM writes during active temperature conversions (-40°C to +85°C)			1200	
Shutdown Current	I <sub>CC1</sub>				2	μA

# Digital Thermometers and Thermostats with SPI/3-Wire Interface

MAX31722/MAX31723

## AC ELECTRICAL CHARACTERISTICS: 3-WIRE INTERFACE

(V<sub>DD</sub> = 1.7V to 3.7V, T<sub>J</sub> = -55°C to +125°C, unless otherwise noted.) (Figures 1, 2)

PARAMETER	SYMBOL	CONDITIONS	MIN	TYP	MAX	UNITS
Data to SCLK Setup	t <sub>DC</sub>	(Notes 5, 6)	35			ns
SCLK to Data Hold	t <sub>CDH</sub>	(Notes 5, 6)	35			ns
SCLK to Data Valid	t <sub>CDD</sub>	(Notes 5, 6, 7)			80	ns
SCLK Low Time	t <sub>CL</sub>	(Note 6)	100			ns
SCLK High Time	t <sub>CH</sub>	(Note 6)	100			ns
SCLK Frequency	t <sub>CLK</sub>	(Note 6)	DC		5.0	MHz
SCLK Rise and Fall	t <sub>R</sub> , t <sub>F</sub>				200	ns
CE to SCLK Setup	t <sub>CC</sub>	(Note 6)	400			ns
SCLK to CE Hold	t <sub>CCH</sub>	(Note 6)	100			ns
CE Inactive Time	t <sub>CWH</sub>	(Note 6)	400			ns
CE to Output High-Z	t <sub>CDZ</sub>	(Notes 5, 6)			40	ns
SCLK to Output High-Z	t <sub>CCZ</sub>	(Notes 5, 6)			40	ns

## AC ELECTRICAL CHARACTERISTICS: SPI INTERFACE

(V<sub>DD</sub> = 1.7V to 3.7V, T<sub>J</sub> = -55°C to +125°C, unless otherwise noted.) (Figures 3, 4)

PARAMETER	SYMBOL	CONDITIONS	MIN	TYP	MAX	UNITS
Data to SCLK Setup	t <sub>DC</sub>	(Notes 5, 6)	35			ns
SCLK to Data Hold	t <sub>CDH</sub>	(Notes 5, 6)	35			ns
SCLK to Data Valid	t <sub>CDD</sub>	(Notes 5, 6, 7)			80	ns
SCLK Low Time	t <sub>CL</sub>	(Note 6)	100			ns
SCLK High Time	t <sub>CH</sub>	(Note 6)	100			ns
SCLK Frequency	t <sub>CLK</sub>	(Note 6)	DC		5.0	MHz
SCLK Rise and Fall	t <sub>R</sub> , t <sub>F</sub>				200	ns
CE to SCLK Setup	t <sub>CC</sub>	(Note 6)	400			ns
SCLK to CE Hold	t <sub>CCH</sub>	(Note 6)	100			ns
CE Inactive Time	t <sub>CWH</sub>	(Note 6)	400			ns
CE to Output High-Z	t <sub>CDZ</sub>	(Notes 5, 6)			40	ns

## AC ELECTRICAL CHARACTERISTICS: EEPROM

(V<sub>DD</sub> = 1.7V to 3.7V, T<sub>J</sub> = -55°C to +125°C, unless otherwise noted.)

PARAMETER	SYMBOL	CONDITIONS	MIN	TYP	MAX	UNITS
EEPROM Write Cycle Time	t <sub>WR</sub>	-40°C to +85°C (Note 8)			15	ms
EEPROM Write Endurance	N <sub>EEWR</sub>	-40°C ≤ T <sub>A</sub> ≤ +85°C (Note 8)	20,000			Cycles
		T <sub>A</sub> = +25°C (Note 8)	80,000			

**Note 1:** All voltages are referenced to ground. Currents entering the IC are specified positive, and currents exiting the IC are negative.

**Note 2:** Logic 0 voltages are specified at a sink current of 3mA.

**Note 3:** Logic 1 voltages are specified at a source current of 1mA.

**Note 4:** I<sub>CC</sub> specified with SCLK = V<sub>DD</sub> and CE = GND.

**Note 5:** Measured at V<sub>IH</sub> = 0.7V × V<sub>DD</sub> or V<sub>IL</sub> = 0.3 × V<sub>DD</sub> and 10ms maximum rise and fall times.

**Note 6:** Measured with 50pF load.

**Note 7:** Measured at V<sub>OH</sub> = 0.7 × V<sub>DD</sub> or V<sub>OL</sub> = 0.3 × V<sub>DD</sub>. Measured from the 50% point of SCLK to the V<sub>OH</sub> minimum of SDO.

**Note 8:** V<sub>DD</sub> must be > 2.0V during EEPROM write cycles.

# Digital Thermometers and Thermostats with SPI/3-Wire Interface

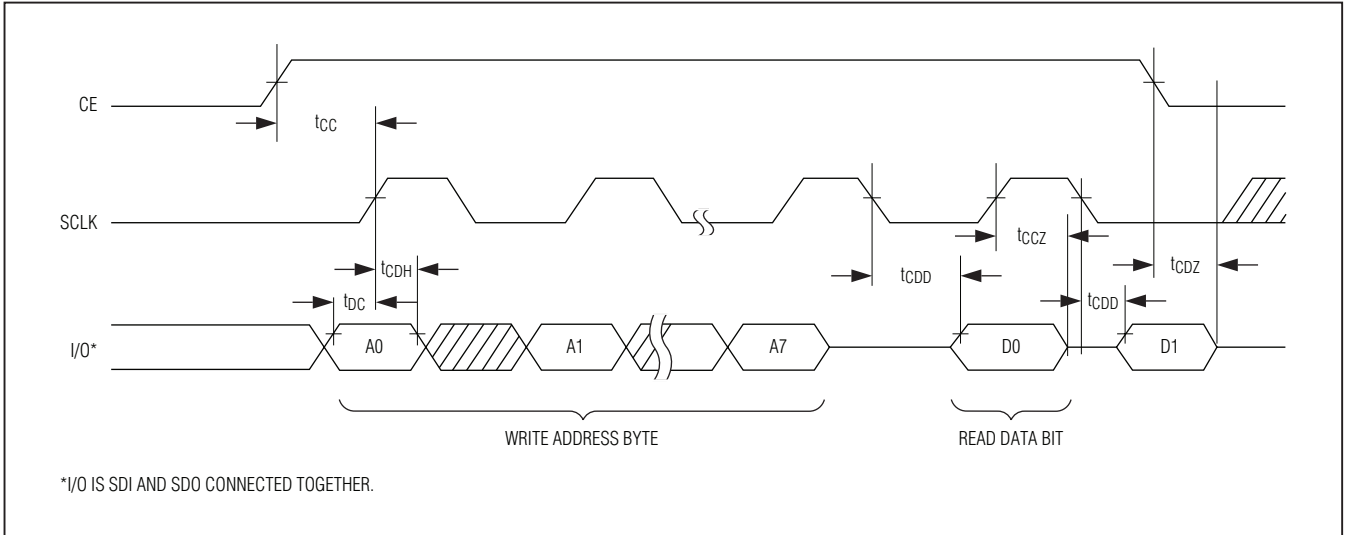

Figure 1. Timing Diagram: 3-Wire Read Data Transfer

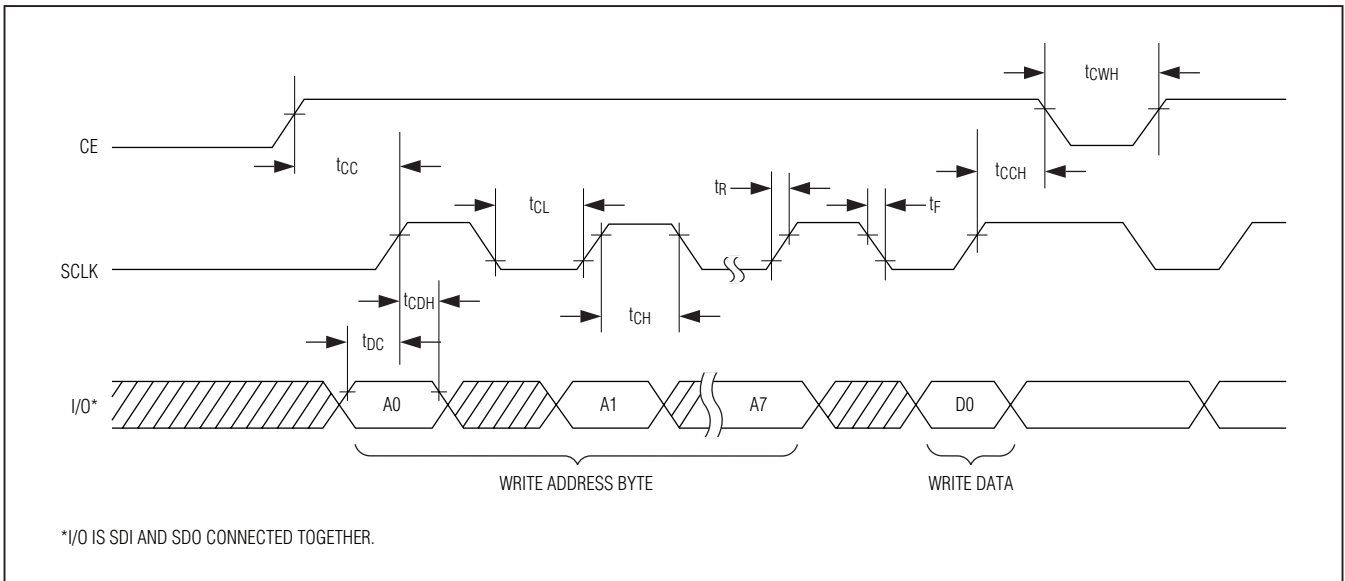

Figure 2. Timing Diagram: 3-Wire Write Data Transfer

# Digital Thermometers and Thermostats with SPI/3-Wire Interface

MAX31722/MAX31723

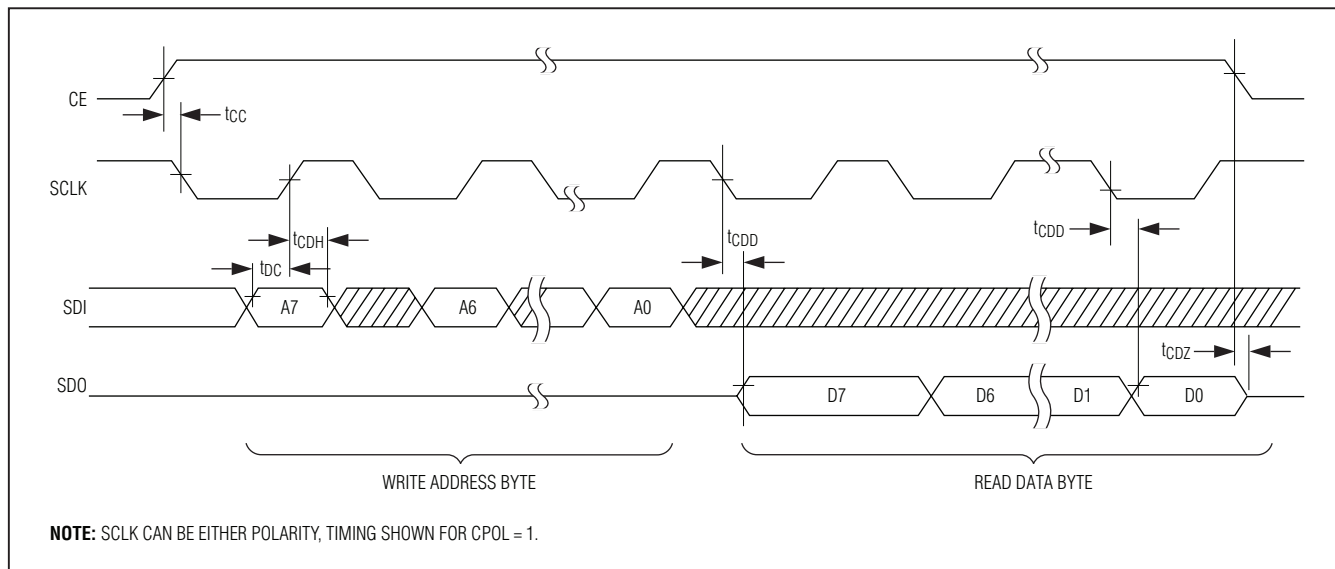

Figure 3. Timing Diagram: SPI Read Data Transfer

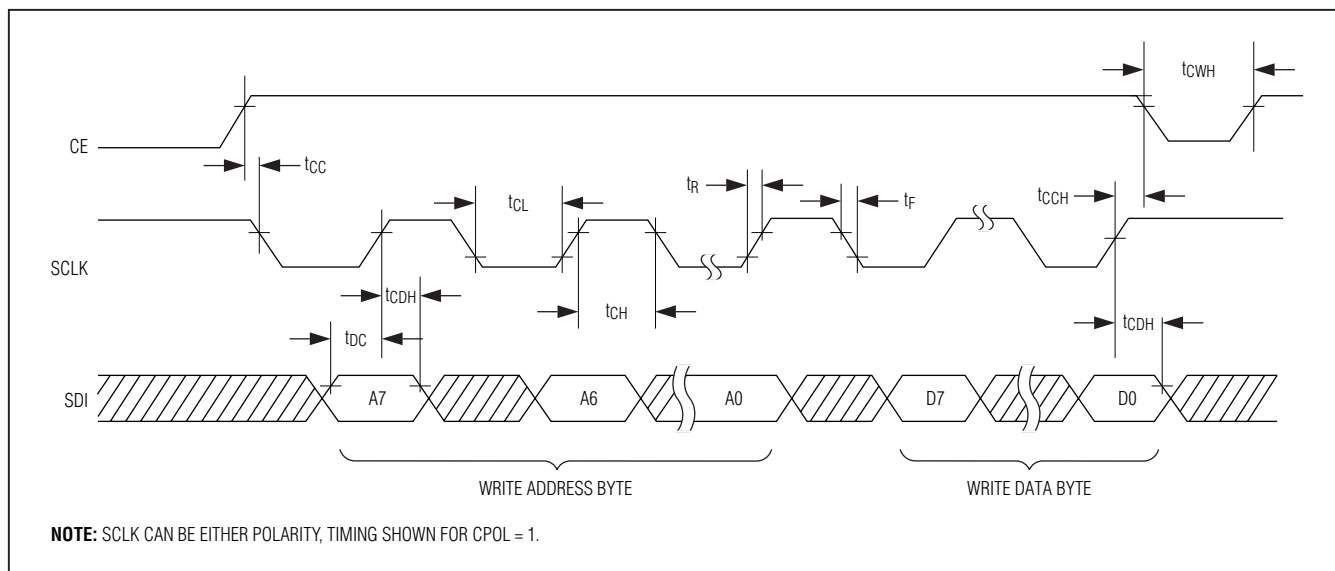
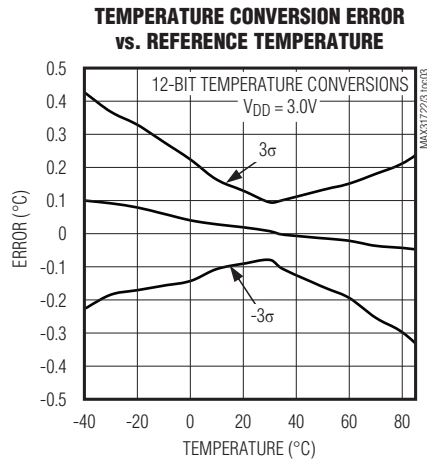
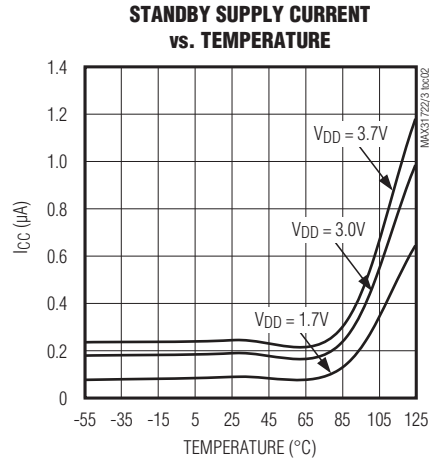
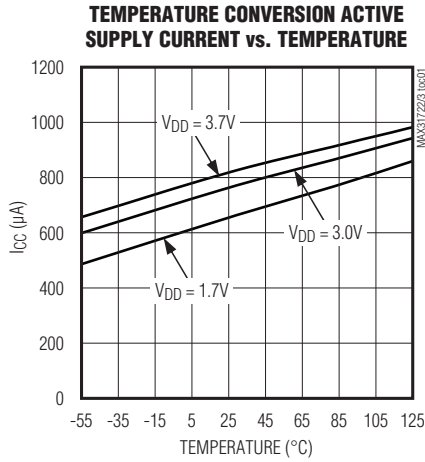

Figure 4. Timing Diagram: SPI Write Data Transfer

# Digital Thermometers and Thermostats with SPI/3-Wire Interface

## Typical Operating Characteristics

(T<sub>A</sub> = +25°C, unless otherwise noted.)



# Digital Thermometers and Thermostats with SPI/3-Wire Interface

MAX31722/MAX31723

## Pin Configuration

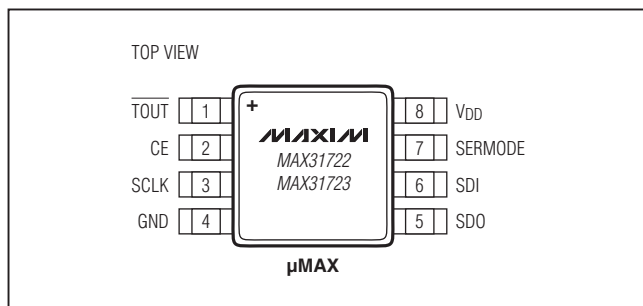

## Pin Description

PIN	NAME	FUNCTION
1	$\overline{\text{TOUT}}$	Thermostat Output. Open-drain output indicator for internal thermal alarm limits.
2	CE	Chip Enable. Must be asserted high for communication to take place for either the SPI or 3-wire interfaces.
3	SCLK	Serial-Clock Input. Used to synchronize data movement on the serial interface for either SPI or 3-wire interfaces.
4	GND	Ground. Ground connection.
5	SDO	Serial-Data Output. When SPI communication is selected, the SDO pin is the serial-data output for the SPI bus. When 3-wire communication is selected, this pin must be connected to the SDI pin. The SDI and SDO pins function as a single I/O pin when connected together.
6	SDI	Serial-Data Input. When SPI communication is selected, the SDI pin is the serial-data input for the SPI bus. When 3-wire communication is selected, this pin must be connected to the SDO pin. The SDI and SDO pins function as a single I/O pin when connected together.
7	SERMODE	Serial-Interface Mode Input. This pin selects which interface is used. When connected to V <sub>DD</sub> , SPI communication is selected. When connected to GND, 3-wire communication is selected.
8	VDD	Supply Voltage. Power-supply input.

## Detailed Description

The MAX31722/MAX31723 are factory-calibrated temperature sensors that require no external components. The user can alter the configuration/status register to place the device in a continuous temperature conversion mode or into a one-shot conversion mode. In the continuous conversion mode, the devices continuously convert the temperature and store the result in the temperature register. As conversions are performed in the background, reading the temperature register does not affect the conversion in progress. In the one-shot temperature conversion mode, the devices perform one temperature conversion, store the result in the temperature register, and then return to the shutdown state. This conversion mode is ideal for power-sensitive applications. The

temperature conversion results have a default resolution of 9 bits. In applications where small incremental temperature changes are critical, the user can change the conversion resolution from 9 bits to 10, 11, or 12. This is accomplished by programming the configuration/status register.

The devices can be configured as a thermostat, allowing for the  $\overline{\text{TOUT}}$  pin to behave as an interrupt, triggering when the programmed limits, T<sub>HIGH</sub> and T<sub>LOW</sub>, are surpassed. The devices can communicate using either a serial peripheral interface (SPI) or standard 3-wire interface. The user can select either communication standard through the SERMODE pin, connecting it to V<sub>DD</sub> for SPI and to GND for 3-wire.

# Digital Thermometers and Thermostats with SPI/3-Wire Interface

## Measuring Temperature

The core of the devices' functionality is its direct-to-digital temperature sensor. The devices measure temperature through the use of an on-chip temperature measurement technique with a  $-55^{\circ}\text{C}$  to  $+125^{\circ}\text{C}$  operating range. The devices power up in a power-conserving shutdown mode. After power-up, the devices can be placed in a continuous conversion mode or in a one-shot conversion mode. In the continuous conversion mode, the devices continuously compute the temperature and store the most recent result in the temperature register at addresses 01h (LSB) and 02h (MSB). As conversions are performed in the background, reading the temperature register does not affect the conversion in progress. The temperature value is not updated until the SPI or 3-wire interface is inactive. In other words, CE must be inactive for the temperature register to be updated with the most recent temperature conversion value. In the one-shot conversion mode, the devices perform one temperature conversion and then return to the shutdown mode, storing temperature in the temperature register. This conversion

mode is ideal for power-sensitive applications. Details on how to change the setting after power-up are contained in the *Programming* section.

The resolution of the temperature conversion is configurable (9, 10, 11, or 12 bits) with 9 bits reading the default state. This equates to a temperature resolution of  $0.5^{\circ}\text{C}$ ,  $0.25^{\circ}\text{C}$ ,  $0.125^{\circ}\text{C}$ , or  $0.0625^{\circ}\text{C}$ . Following each conversion, thermal data is stored in the temperature register in two's complement format. The information can be retrieved over the SPI or 3-wire interface with the address set to the temperature register, 01h (LSB) and then 02h (MSB). Table 1 describes the exact relationship of output data to measured temperature. Table 1 assumes the devices are configured for 12-bit resolution. If the devices are configured in a lower resolution mode, those bits contain zeros. The data is transmitted serially over the digital interface, MSB first for SPI communication and LSB first for 3-wire communication. The MSB of the temperature register contains the sign (S) bit, denoting whether the temperature is positive or negative.

S	2 <sup>6</sup>	2 <sup>5</sup>	2 <sup>4</sup>	2 <sup>3</sup>	2 <sup>2</sup>	2 <sup>1</sup>	2 <sup>0</sup>	02h
(UNITS = $^{\circ}\text{C}$ )								
MSB							LSB	
2 <sup>-1</sup>	2 <sup>-2</sup>	2 <sup>-3</sup>	2 <sup>-4</sup>	0	0	0	0	01h

Figure 5. Temperature,  $T_{\text{HIGH}}$ , and  $T_{\text{LOW}}$  Register Format

Table 1. 12-Bit Resolution Temperature/Data Relationship

TEMPERATURE ( $^{\circ}\text{C}$ )	DIGITAL OUTPUT (BINARY)	DIGITAL OUTPUT (HEX)
+125	0111 1101 0000 0000	7D00
+25.0625	0001 1001 0001 0000	1910
+10.125	0000 1010 0010 0000	0A20
+0.5	0000 0000 1000 0000	0080
0	0000 0000 0000 0000	0000
-0.5	1111 1111 1000 0000	FF80
-10.125	1111 0101 1110 0000	F5E0
-25.0625	1110 0110 1111 0000	E6F0
-55	1100 1001 0000 0000	C900



# Digital Thermometers and Thermostats with SPI/3-Wire Interface

## Thermostat

The devices' thermostat can be programmed to power up in either comparator mode or interrupt mode, which activate and deactivate the open-drain thermostat output ( $\overline{\text{TOUT}}$ ) based on user-programmable trip points ( $T_{\text{HIGH}}$  and  $T_{\text{LOW}}$ ). The  $T_{\text{HIGH}}$  and  $T_{\text{LOW}}$  registers contain Celsius temperature values in two's complement format and are stored in EEPROM memory. As such, the values are nonvolatile and can be programmed prior to installing the devices for stand-alone operation.

The data format of the  $T_{\text{HIGH}}$  and  $T_{\text{LOW}}$  registers is identical to that of the temperature register (Figure 5). After every temperature conversion, the measurement is compared to the values stored in the  $T_{\text{HIGH}}$  and  $T_{\text{LOW}}$  registers. The  $T_{\text{HIGH}}$  register is assigned to address locations 03h (LSB) and 04h (MSB), and the  $T_{\text{LOW}}$  register is assigned to address locations 05h (LSB) and 06h (MSB). The  $\overline{\text{TOUT}}$  output is updated based on the result of the comparison and the operating mode of the devices. The number of  $T_{\text{HIGH}}$  and  $T_{\text{LOW}}$  bits used during the thermostat comparison is equal to the conversion resolution set by the R1 and R0 bits in the configuration/status register. For example, if the resolution is 9 bits, only the nine MSBs of  $T_{\text{HIGH}}$  and  $T_{\text{LOW}}$  are used by the thermostat comparator.

If the user does not wish to use the thermostat capabilities of the devices, the  $\overline{\text{TOUT}}$  output should be left unconnected. Note that if the thermostat is not used, the  $T_{\text{HIGH}}$  and  $T_{\text{LOW}}$  registers can be used for general storage of system data.

## Comparator Mode

When the thermostat is in comparator mode,  $\overline{\text{TOUT}}$  can be programmed to operate with any amount of hysteresis. The  $\overline{\text{TOUT}}$  output becomes active when the measured temperature exceeds the  $T_{\text{HIGH}}$  value.  $\overline{\text{TOUT}}$  then stays active until the first time the temperature falls below the value stored in  $T_{\text{LOW}}$ . Putting the devices into shutdown mode does not clear  $\overline{\text{TOUT}}$  in comparator mode. Figure 6 illustrates thermostat comparator mode operation.

## Interrupt Mode

In interrupt mode, the  $\overline{\text{TOUT}}$  output first becomes active when the measured temperature exceeds the  $T_{\text{HIGH}}$  value. Once activated, in continuous conversion mode  $\overline{\text{TOUT}}$  can only be cleared by either putting the devices into shutdown mode or by reading from any register (configuration/status, temperature,  $T_{\text{HIGH}}$ , or  $T_{\text{LOW}}$ ) on the devices. In one-shot mode,  $\overline{\text{TOUT}}$  can only be cleared by reading from any register (configuration/status, temperature,  $T_{\text{HIGH}}$ , or  $T_{\text{LOW}}$ ) on the devices.

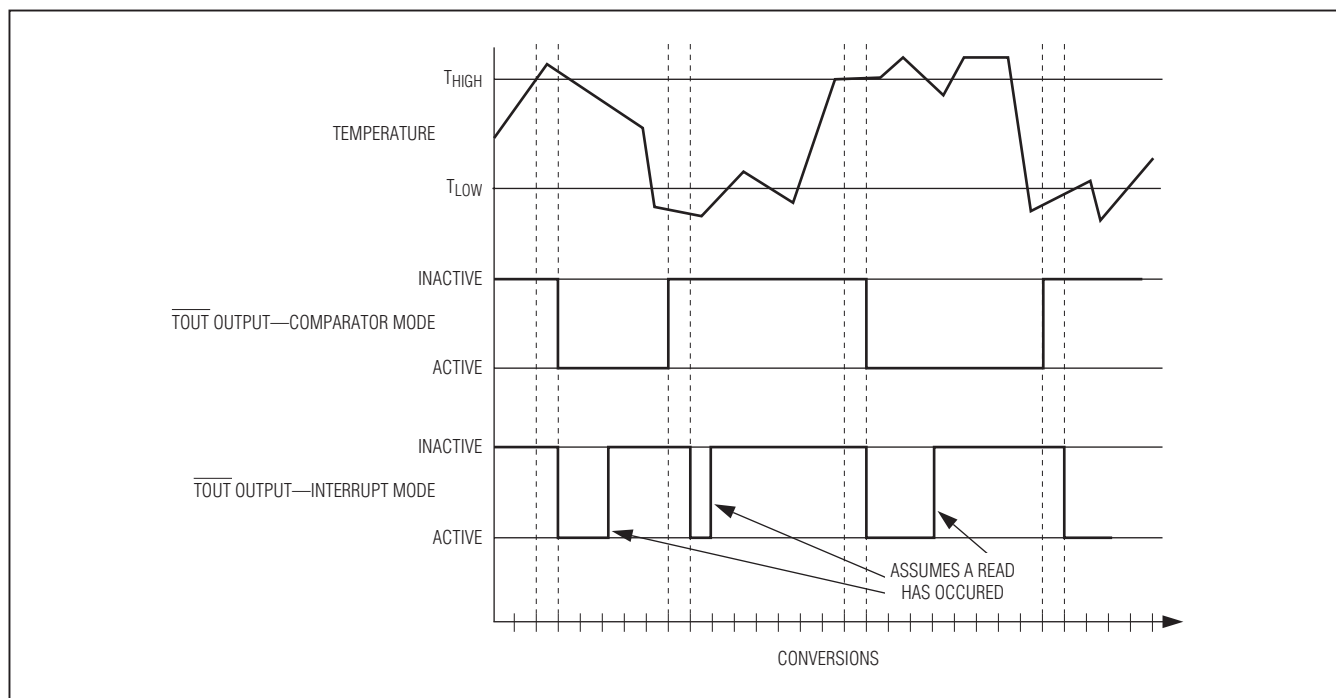

Figure 6.  $\overline{\text{TOUT}}$  Operation Example

# Digital Thermometers and Thermostats with SPI/3-Wire Interface

In either mode, once  $\overline{\text{TOUT}}$  has been deactivated, it is only reactivated when the measured temperature falls below the  $T_{\text{LOW}}$  value. Thus, this interrupt/clear process is cyclical between  $T_{\text{HIGH}}$  and  $T_{\text{LOW}}$  events (i.e.,  $T_{\text{HIGH}}$ , clear,  $T_{\text{LOW}}$ , clear,  $T_{\text{HIGH}}$ , clear,  $T_{\text{LOW}}$ , clear, etc.). Figure 6 illustrates the thermostat interrupt mode operation.

**Table 2. Register Address Structure**

READ ADDRESS (HEX)	WRITE ADDRESS (HEX)	ACTIVE REGISTER
00	80	Configuration/Status
01	No access	Temperature LSB
02	No access	Temperature MSB
03	83	$T_{\text{HIGH}}$ LSB
04	84	$T_{\text{HIGH}}$ MSB
05	85	$T_{\text{LOW}}$ LSB
06	86	$T_{\text{LOW}}$ MSB

## Programming

The area of interest in programming the devices is the configuration/status register. All programming is done through the SPI or 3-wire communication interface by selecting the appropriate address of the desired register location. Table 2 illustrates the addresses for the device registers.

### Configuration/Status Register Programming

The configuration/status register is accessed in the devices with the 00h address for reads and the 80h address for writes. Data is read from or written to the configuration/status register MSB first for SPI communication and LSB first for 3-wire communication. Table 3 illustrates the format of the register, describes the effect each bit has on device functionality, and provides the bit's factory state.

Table 4 defines the resolution of the digital thermometer, based on the settings of the R1 and R0 bits. There is a direct trade-off between resolution and conversion time,

**Table 3. Configuration/Status Register Bit Descriptions**

BIT 7	BIT 6	BIT 5	BIT 4	BIT 3	BIT 2	BIT 1	BIT 0
0	MEMW	NVB	1SHOT	TM	R1	R0	SD

BIT 7	This bit is always a value of 0.
BIT 6	<p><b>MEMW:</b> Memory write bit. Power-up state = 0. The user has read/write access to the MEMW bit, which is stored in the voltage memory.</p> <p>0 = A write of the configuration/status register is stored in RAM memory.</p> <p>1 = A write of the configuration/status register is stored in EEPROM.</p> <p><b>Note:</b> The status of this bit is ignored if a EEPROM write occurs to the other nonvolatile registers, <math>T_{\text{HIGH}}</math> and <math>T_{\text{LOW}}</math>. The nonvolatile bits of the configuration/status register are written if a EEPROM write cycle occurs to the <math>T_{\text{HIGH}}</math> and <math>T_{\text{LOW}}</math> registers.</p>
BIT 5	<p><b>NVB:</b> Nonvolatile memory busy flag. Power-up state = 0 and is stored in volatile memory.</p> <p>0 = Indicates that the nonvolatile memory is not busy.</p> <p>1 = Indicates there is a write to a EEPROM memory cell in progress.</p>
BIT 4	<p><b>1SHOT:</b> One-shot temperature conversion bit. Power-up state = 0 and is stored in volatile memory.</p> <p>0 = Disables 1SHOT mode.</p> <p>1 = If the SD bit is 1 (continuous temperature conversions are not taking place), a 1 written to the 1SHOT bit causes the devices to perform one temperature conversion and store the results in the temperature register at addresses 01h (LSB) and 02h (MSB). The bit clears itself to 0 upon completion of the temperature conversion. The user has read/write access to the 1SHOT bit, although writes to this bit are ignored if the SD bit is a 0 (continuous conversion mode).</p>
BIT 3	<p><b>TM:</b> Thermostat operating mode. Factory power-up state = 0. The user has read/write access to the TM bit, which is stored in nonvolatile memory.</p> <p>0 = The thermostat output is in comparator mode.</p> <p>1 = The thermostat output is in interrupt mode.</p>

# Digital Thermometers and Thermostats with SPI/3-Wire Interface

**Table 3. Configuration/Status Register Bit Descriptions (continued)**

BIT 2	<b>R1:</b> Thermostat resolution bit 1. Factory power-up state = 0 and is stored in nonvolatile memory. Sets the conversion resolution (see Table 4).
BIT 1	<b>R0:</b> Thermostat resolution bit 0. Factory power-up state = 0 and is stored in nonvolatile memory. Sets the conversion resolution (see Table 4).
BIT 0	<b>SD:</b> Factory power-up state = 1. The user has read/write access to the SD bit, which is stored in nonvolatile memory. 0 = The devices continuously perform temperature conversions and store the last completed result in the temperature register. 1 = The conversion in progress is completed and stored, and then the devices revert to a low-power shutdown mode. The communication port remains active.

**Table 4. Thermometer Resolution Configuration**

R1	R0	THERMOMETER RESOLUTION (BITS)	MAX CONVERSION TIME (ms)
0	0	9	25
0	1	10	50
1	0	11	100
1	1	12	200

as depicted in the *AC Electrical Characteristics*. The user has read/write access to the R1 and R0 bits, which are nonvolatile. See Table 4.

## Serial Interface

The devices offer the flexibility to choose between two serial interface modes. They can communicate with the SPI interface or with a 3-wire interface. The interface method used is determined by the SERMODE pin. When SERMODE is connected to VDD, SPI communication is selected. When SERMODE is connected to ground, 3-wire communication is selected.

**Table 5. Function Table**

MODE	CE	SCLK	SDI	SDO
Disable reset	Low	Input disabled	Input disabled	High impedance
Write	High	CPOL = 1*, SCLK rising	Data bit latch	High impedance
		CPOL = 0, SCLK falling		
Read	High	CPOL = 1, SCLK falling	X	Next data bit shift**
		CPOL = 0, SCLK rising		

**Note:** CPHA bit polarity must be set to 1.

\*CPOL is the clock polarity bit that is set in the control register of the microcontroller.

\*\*SDO remains at high impedance until 8 bits of data are ready to be shifted out during a read.

## Serial Peripheral Interface (SPI)

The SPI is a synchronous bus for address and data transfer. The SPI mode of serial communication is selected by connecting SERMODE to VDD. Four pins are used for the SPI: SDO (serial-data out), SDI (serial-data in), CE (chip enable), and SCLK (serial clock). The devices are the slave device in an SPI application, with the microcontroller being the master. SDI and SDO are the serial-data input and output pins for the devices, respectively. The CE input is used to initiate and terminate a data transfer. SCLK is used to synchronize data movement between the master (microcontroller) and the slave (IC) devices.

The serial clock (SCLK), which is generated by the microcontroller, is active only when CE is high and during address and data transfer to any device on the SPI bus. The inactive clock polarity is programmable in some microcontrollers. The devices offer an important feature in that the level of the inactive clock is determined by sampling SCLK when CE becomes active. Therefore, either SCLK polarity can be accommodated. Input data (SDI) is latched on the internal strobe edge and output data (SDO) is shifted out on the shift edge (see Table 5 and Figure 7). There is one clock for each bit transferred. Address and data bits are transferred in groups of eight, MSB first.

# Digital Thermometers and Thermostats with SPI/3-Wire Interface

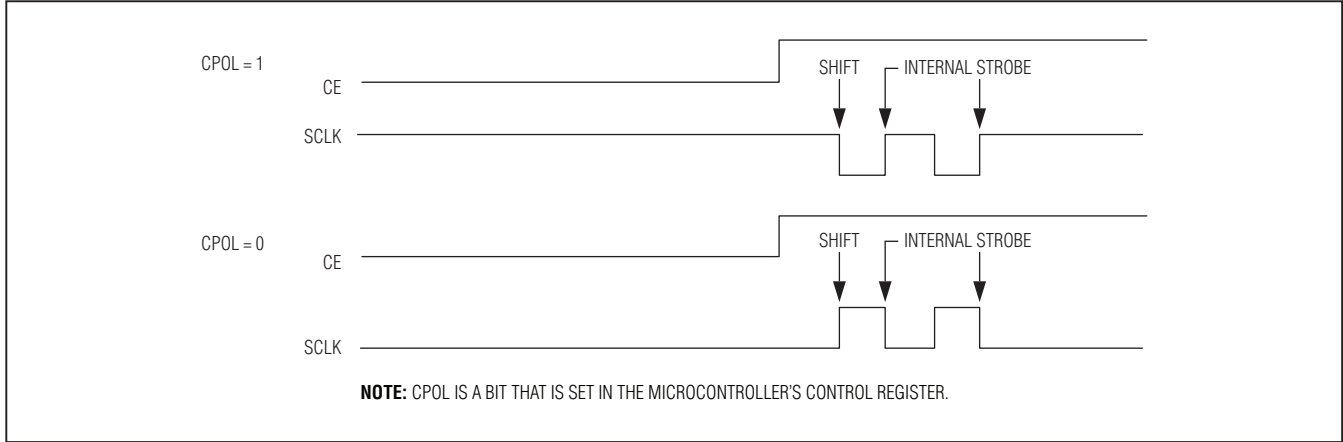

Figure 7. Serial Clock as a Function of Microcontroller Clock Polarity (CPOL)

### Address and Data Bytes

Address and data bytes are shifted MSB first into the serial-data input (SDI) and out of the serial-data output (SDO). Any transfer requires the address of the byte to specify a write or a read, followed by one or more bytes of data. Data is transferred out of the SDO for a read operation and into the SDI for a write operation. The address byte is always the first byte entered after CE is driven high. The MSB (A7) of this byte determines if a read or write takes place. If A7 is 0, one or more read cycles occur. If A7 is 1, one or more write cycles occur.

Data transfers can occur 1 byte at a time in multiple-byte burst mode. After CE is driven high, an address is written to the devices. After the address, one or more data bytes can be written or read. For a single-byte transfer, 1 byte is read or written and then CE is driven low (see Figures 8 and 9). For a multiple-byte transfer, however, multiple bytes can be read or written to the devices after the address has been written (see Figure 10). A

single-byte burst read/write sequentially points through all memory locations and loops from 7Fh/FFh to 00h/80h. Invalid memory addresses report an FFh value.

### 3-Wire Serial-Data Bus

The 3-wire communication mode operates similarly to the SPI mode. However, in 3-wire mode, there is one bidirectional I/O instead of separate data-in and data-out signals. The 3-wire consists of the I/O (SDI and SDO pins connected together), CE, and SCLK pins. In 3-wire mode, each byte is shifted in LSB first, unlike SPI mode where each byte is shifted in MSB first. As is the case with the SPI mode, an address byte is written to the devices followed by a single data byte or multiple data bytes. Figure 11 illustrates a read and write cycle. Figure 12 illustrates a multiple-byte burst transfer. In 3-wire mode, data is input on the rising edge of SCLK and output on the falling edge of SCLK.

# Digital Thermometers and Thermostats with SPI/3-Wire Interface

MAX31722/MAX31723

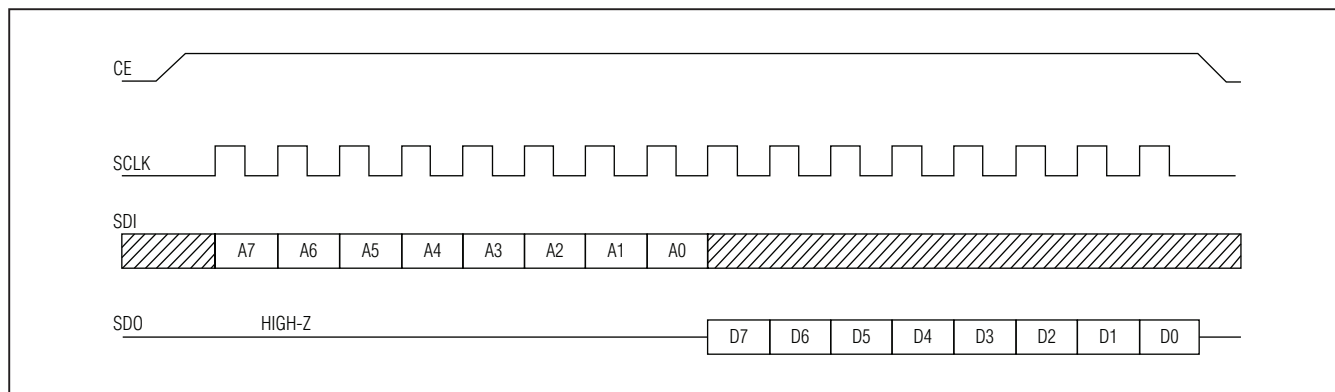

Figure 8. SPI Single-Byte Read

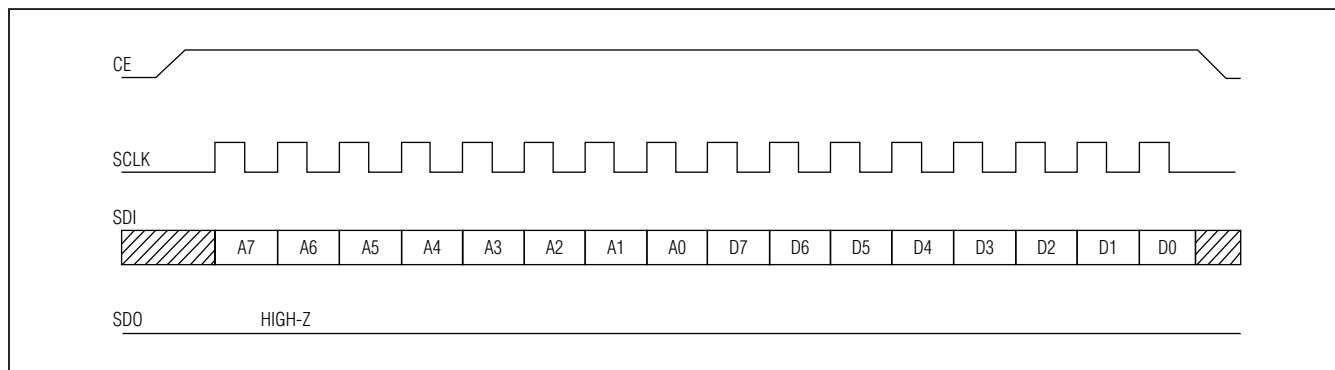

Figure 9. SPI Single-Byte Write

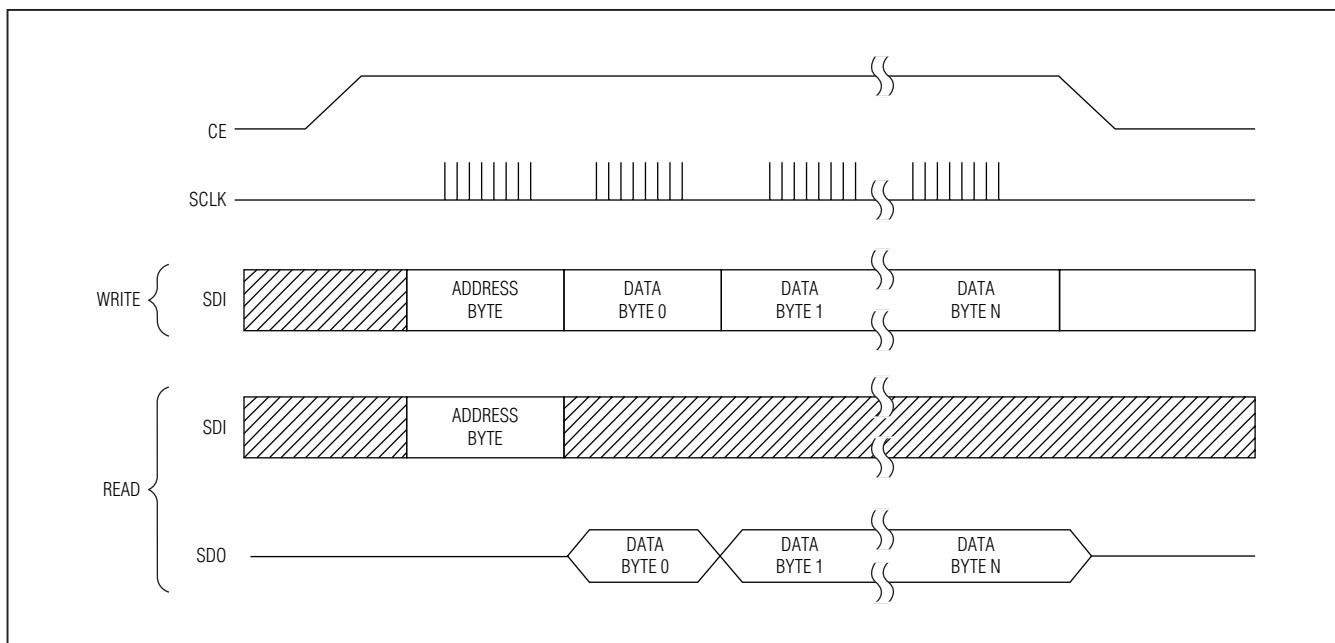

Figure 10. SPI Multiple-Byte Burst Transfer

# Digital Thermometers and Thermostats with SPI/3-Wire Interface

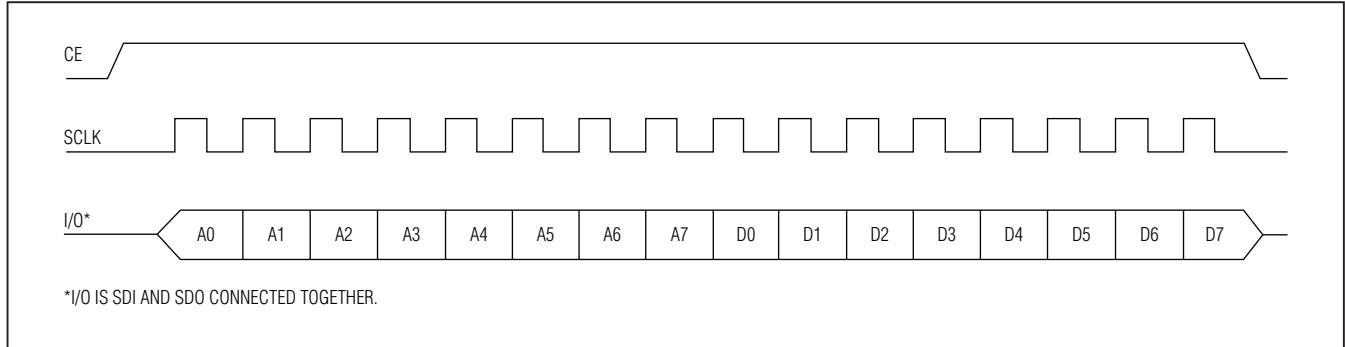

Figure 11. 3-Wire Single-Byte Transfer

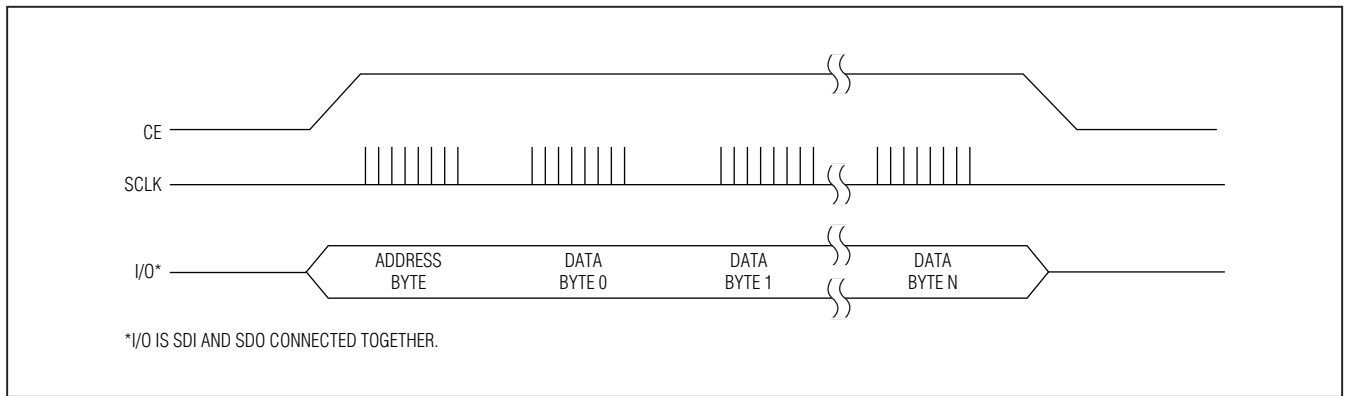

Figure 12. 3-Wire Multiple-Byte Burst Transfer

## Package Information

For the latest package outline information and land patterns, go to [www.maxim-ic.com/packages](http://www.maxim-ic.com/packages). Note that a "+", "#", or "-" in the package code indicates RoHS status only. Package drawings may show a different suffix character, but the drawing pertains to the package regardless of RoHS status.

PACKAGE TYPE	PACKAGE CODE	OUTLINE NO.	LAND PATTERN NO.
8 $\mu$ MAX	U8+1	<a href="#">21-0036</a>	<a href="#">90-0092</a>

# Digital Thermometers and Thermostats with SPI/3-Wire Interface

## Revision History

REVISION NUMBER	REVISION DATE	DESCRIPTION	PAGES CHANGED
0	11/10	Initial release	—

MAX31722/MAX31723

Maxim cannot assume responsibility for use of any circuitry other than circuitry entirely embodied in a Maxim product. No circuit patent licenses are implied. Maxim reserves the right to change the circuitry and specifications without notice at any time.

**Maxim Integrated Products, 120 San Gabriel Drive, Sunnyvale, CA 94086 408-737-7600** \_\_\_\_\_ 15

© 2010 Maxim Integrated Products

Maxim is a registered trademark of Maxim Integrated Products, Inc.