

Remote Sensor Amplifier Terminal

SRT1-□□D04S

Plug-in Sensor Amplifiers with Direct CompoBus/S Terminal Connections

- SRT1 models support only high-speed communications systems
- 4-point terminals expand to 8 points max. with optional expansion terminal
- Easily mounts to DIN rail track or with screws for panel mounting

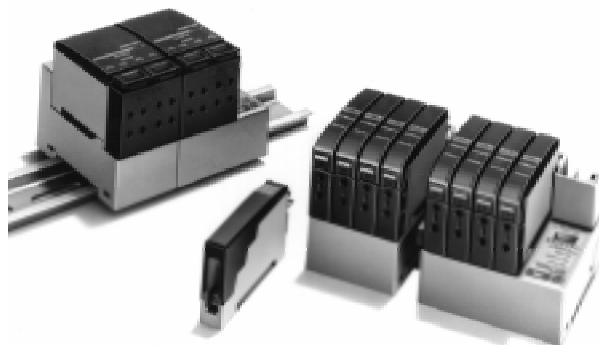

Ordering Information

■ COMPOBUS/S SENSOR AMPLIFIER TERMINALS

Classification	Applicable sensor amplifier models	I/O points	Part number
Communications	E3X-NT□6, E39-JID01 or E2C-T16 amplifiers	4 single-point amplifiers	SRT1-TID04S
	E3X-NM16 amplifier	1 four-point amplifier	SRT1-TKD04S
Expansion	E3X-NT□6, E39-JID01 or E2C-T16 amplifiers	4 single-point amplifiers	SRT1-XID04S
	E3X-NM16 amplifier	1 four-point amplifier	SRT1-XKD04S

■ SENSOR AMPLIFIERS

The amplifiers and terminal block below do not include the required sensing head. Order those separately from the partial listing below. For detailed sensor performance specifications and a complete product offering, request a Sensing Products catalog or visit our web site at www.omron.com/oei.

Classification	Specifications	Part number
Fiber-optic sensor amplifiers for Omron's E32-series fiber-optic cables	General-purpose amplifier, 1 channel	E3X-NT16
	Multi-functional amplifier, 1 channel, with OFF-delay timer and teach function	E3X-NT26
	Long distance, high accuracy amplifier, 1 channel, 3 teach modes, scaled sensitivity and threshold displays	E3X-NH16
	Multi-functional amplifier, 4 channels, with OFF-delay timer and teach function	E3X-NM16
Inductive proximity sensor amplifier	Sensor detects all metal targets, offers teach function, 1 channel; use E2C sensing heads	E2C-T16
Terminal block	Connect any 2-wire or 3-wire DC photoelectric or proximity sensor, limit switch or basic switch; 1 channel	E39-JID01

■ SENSING HEADS FOR AMPLIFIERS

Applicable amplifier	Description	Sensing distance	Part number
Fiber-optic amplifiers E3X-NT, E3X-NM, E3X-NH	General-purpose through-beam	E3X-NT: 290 mm E3X-NM: 270 mm E3X-NH: 400 mm	E32-TC200
	Long-distance, through-beam	E3X-NT: 7.5 m E3X-NM: 7 m E3X-NH: 14 m	E32-T17L
	Armored, high-temperature (300°C) through-beam	E3X-NT: 190 mm E3X-NM: 180 mm E3X-NH: 300 mm	E32-T61
	General-purpose, diffuse	E3X-NT: 110 mm E3X-NM: 100 mm E3X-NH: 150 mm	E32-DC200
	Armored high-temperature (300°C) diffuse	E3X-NT: 50 mm E3X-NM: 45 mm E3X-NH: 45 mm	E32-D61
Inductive proximity sensor amplifier E2C-T16	Unshielded, 2 mm dia. head	0.7 mm	E2C-CR5B2
	Shielded, 3.5 mm dia. head	1.2 mm	E2C-CR8A
	Shielded, M5 threaded head	1.5 mm	E2C-X1A
	Shielded, 5.4 mm dia. head	1.5 mm	E2C-C1A
	Shielded, M8 threaded head	2 mm	E2C-X1R5A

Application Examples

Low Cost, Space Saving Fiber-optic Sensor Installation Uses Four-channel Fiber Amps

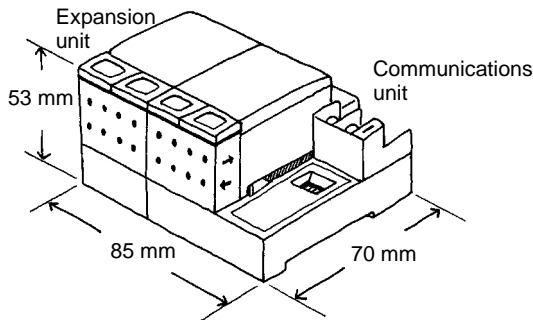

Just Snap On to Connect Four Individual Sensor Amplifiers or Terminal Block

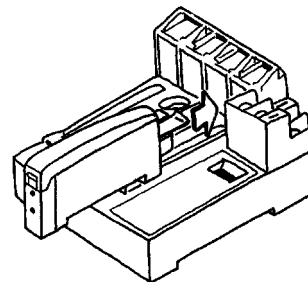

Sensor Amplifiers and Terminal Block

Fiber-optic amplifier (1 channel)

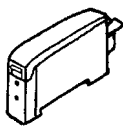

Inductive Proximity amplifier (1 channel)

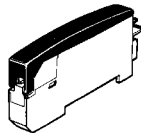

Terminal Block Unit (1 channel)

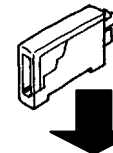

Various sensor and switch types can be connected.

Fiber-optic amplifier (4 channels)

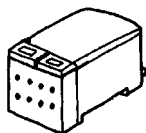

Photoelectric sensor

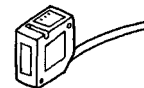

Basic switch and limit switch



Proximity sensor



Specifications

■ CHARACTERISTICS

CompoBus/S Sensor Amplifier Terminals

Item	Communication terminals		Expansion terminals	
Model	SRT1-TID04S	SRT1-TKD04S	SRT1-XID04S	SRT1-XKD04S
Communications power supply voltage	14 to 26.4 VDC (See Note 1)		---	---
I/O points	4 input points			
Connected sensors	Total of four E3X-NT□6 or E39-JID01 (See Note 2)	One E3X-NM16 (See Note 2)	Total of four E3X-NT□6 or E39-JID01	One E3X-NM16
Current consumption	60 mA max. (See Note 3)		10 mA max. (See Note 3)	
Dielectric strength	500 VAC for 1 min (1 mA sensing current between insulated circuits)			
Noise immunity	Power supply normal: ± 600 V for 10 minutes with a pulse width of 100 ns to 1 μ s Power supply common: $\pm 1,500$ V for 10 minutes with a pulse width of 100 ns to 1 μ s			
Vibration resistance	10 to 55 Hz, 1.5 mm double amplitude			
Shock resistance	Malfunction: 200 m/s ² Destruction: 300 m/s ²			
Mounting method	M4 screw mounting or 35 mm DIN track mounting			
Mounting strength	No damage when 50 N pull load was applied for 10 s in all directions (except the DIN track directions and a pulling force of 10 N)			
Terminal strength	No damage when 49 N pull load was applied for 10 s in all directions. Tighten each screw to a torque of 0.6 to 1.18 N • m.			
Ambient temperature	Operating: 0°C to 55°C (32° to 131°F) with no icing or condensation Storage: -20°C to 65°C (-4° to 149°F) with no icing or condensation			
Ambient humidity	Operating: 35% to 85%			
Weight	70 g max.	65 g max.	45 g max.	35 g max.

- Note: 1. The communications power supply voltage must be 20.4 to 26.4 VDC if the Terminal is connected to 2-wired proximity sensors.
2. When adding Amplifier Terminals, use SRT1-XID04S or SRT1-XKD04S.
3. The value doesn't include the current consumption of Amplifier Terminals.

E3X-N□ Fiber-optic Amplifiers

Model	E3X-NH16	E3X-NT16	E3X-NT26	E3X-NM16
Current consumption	75 mA max.	50 mA max.		150 mA
Response time	1 ms max. (4.0 ms max. when connected to the SRM1-□□D04S)	500 μ s max. (2.0 ms max. when connected to the SRT1-□□D04S)		
Timer function	Not available		OFF-delay timer (fixed to 40 ms)	
Remote teaching input	Not available		Available (Remote teaching disabled)	
Indicator	Orange LED: Lit during output operation Green LED: Lit with stable light reception or no light			
Teaching confirmation	Indicators (red/green LED) and buzzer			
Output	Light ON and Dark ON switch selectable			
Ambient illumination	Sunlight: 10,000 lux max.; incandescent lamp: 3,000 lux max.			
Insulation resistance	20 M Ω max. at 500 VDC			
Dielectric strength	1,000 VAC at 50/60 Hz for 1 minute			
Vibration resistance	Destruction: 10 to 55 Hz, 1.5 mm double amplitude			
Shock resistance	Destruction: 500 m/s ²			
Mounting method	Connector connection to the SRT1-□□D04S			
Mounting strength	No damage when 49 N pull load was applied for 10 s in all directions			
Ambient temperature	Operating: 0°C to 55°C (32° to 131°F) with no icing or condensation Storage: -20°C to 65°C (-4° to 149°F) with no icing or condensation			
Ambient humidity	Operating: 35% to 85%			
Weight	30 g max.	30 g max.	30 g max.	60 g max.

Proximity Sensor Amplifier

Model	E2C-T16
Current consumption	50 mA max.
Response time	Depends on the response frequency of the sensing head: 1 kHz for E2C-CR5B2, E2C-CR8A, E2C-X1A, E2C-C1A 800 Hz for E2C-X1R5A
Teaching input	Manual
Indicator	Orange LED: Lit during output operation Green LED: Lit with stable signal input
Temperature influence	±25% max. of sensing distance at 23°C for E2C-CR5B2 ±10% max. of sensing distance at 23°C for E2C-CR5B2, E2C-CR8A, E2C-X1A, E2C-C1A
Differential travel	15% max of sensing distance for E2C-CR5B2 10% max. of sensing distance for E2C-CR5B2, E2C-CR8A, E2C-X1A, E2C-C1A
Cable length compensation	3 m for E2C-CR5B2 1, 2 or 3 m selectable for E2C-CR5B2, E2C-CR8A, E2C-X1A, E2C-C1A
Insulation resistance	50 M Ω max. at 500 VDC between current carrying parts and case
Dielectric strength	1,000 VAC at 50/60 Hz for 1 minute between current carrying parts and case
Vibration resistance	Destruction: 10 to 55 Hz, 1.5 mm double amplitude for 2 hours each in X, Y, and Z directions
Shock resistance	Destruction: 500 m/s ² (approx. 50G) three times each in X, Y, and Z directions
Mounting method	Connector connection to the SRT1-□□D04S
Mounting strength	No damage when 49 N pull load was applied for 10 s in all directions
Ambient temperature	Operating: 0°C to 55°C (32° to 131°F) with no icing or condensation Storage: -20°C to 65°C (-4° to 149°F) with no icing or condensation
Ambient humidity	Operating: 35% to 85%
Weight	70 g

Terminal Block Unit

Model	E39-JID01
Input current	10 mA max.
ON voltage	12 VDC min. between input terminal and external sensor power supply
OFF voltage	4 VDC max. between input terminal and external sensor power supply
OFF current	1 mA max.
ON delay time	1 ms max. (connected to SRT1-□□D04S)
OFF delay time	1.5 ms max. (connected to SRT1-□□D04S)
Input indicators	LED (Orange)
External sensor current capacity	50 mA max.
Vibration resistance	10 to 55 Hz, 1.5 mm double amplitude
Shock resistance	Malfunction: 200 m/s ² Destruction: 300 m/s ²
Mounting method	M4 screws or 35 mm DIN track mounting
Mounting strength	No damage when 50 N pull load was applied for 10 s in all directions (except the DIN track directions and a pulling force of 10 N)
Terminal strength	No damage when 49 N pull load was applied for 10 s in all directions. Tighten each screw to a torque of 0.6 to 1.18 N • m.
Ambient temperature	Operating: 0°C to 55°C (32° to 131°F) with no icing or condensation Storage: -20°C to 65°C (-4° to 149°F) with no icing or condensation
Ambient humidity	Operating: 35% to 85%
Weight	25 g max.

Nomenclature

SRT1-TID04S
SRT1-TKD04S

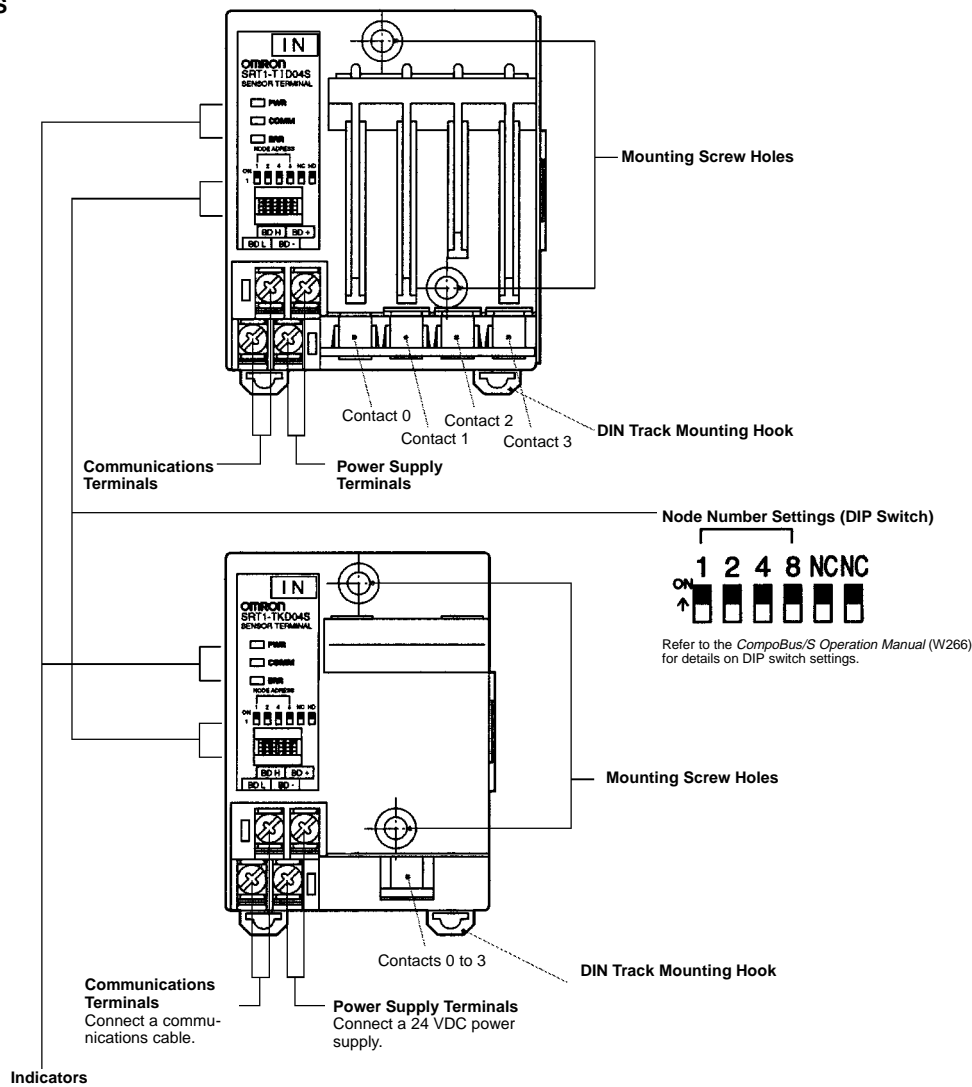

Indicators

Indicator	Name	Display	Color	Meaning
PWR	Power supply	Lit	Green	The communications power supply is ON.
		Not lit		The communications power supply is OFF.
COMM	Communications	Lit	Yellow	Normal communications.
		Not lit		A communications error has occurred or the Module is in standby status.
ERR	Communications error	Lit	Red	A communications error has occurred.
		Not lit		Normal communications or the Module is in standby status.

Node Number Settings

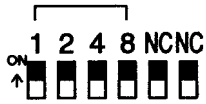

Node number	1	2	4	8
0	OFF	OFF	OFF	OFF
1	ON	OFF	OFF	OFF
2	OFF	ON	OFF	OFF
3	ON	ON	OFF	OFF
4	OFF	OFF	ON	OFF
5	ON	OFF	ON	OFF
6	OFF	ON	ON	OFF
7	ON	ON	ON	OFF
8	OFF	OFF	OFF	ON
9	ON	OFF	OFF	ON
10	OFF	ON	OFF	ON
11	ON	ON	OFF	ON
12	OFF	OFF	ON	ON
13	ON	OFF	ON	ON
14	OFF	ON	ON	ON
15	ON	ON	ON	ON

Note: For node number settings, refer to the *CompoBus/S Operation Manual (W266)*.

Dimensions

Unit: mm (inch)

SRT1-TID04

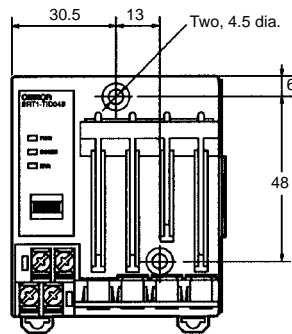
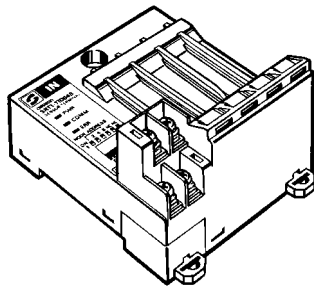

Mounting Holes

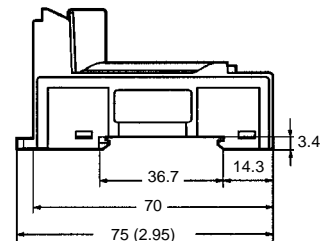
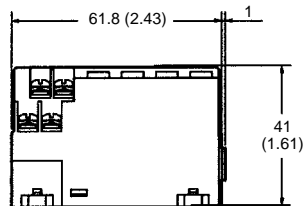
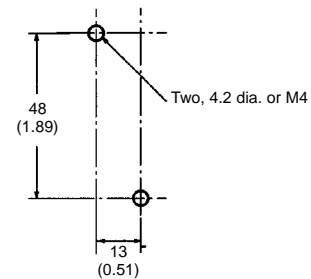

SRT1-XID04S

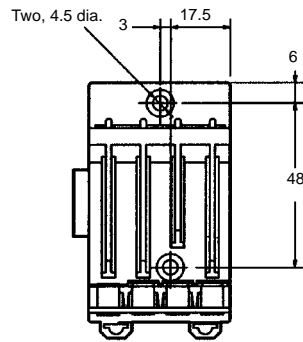
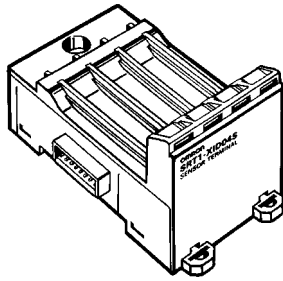

Mounting Holes

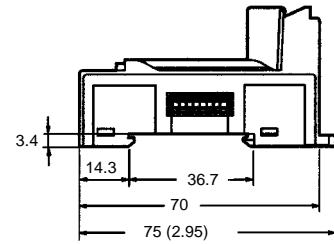
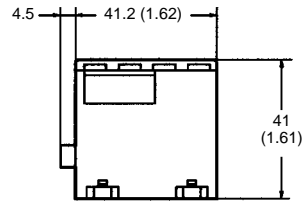
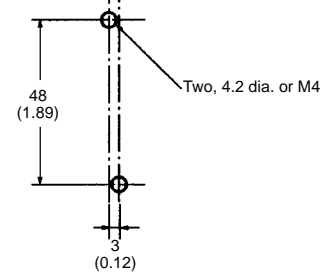

SRT1-TKD04S

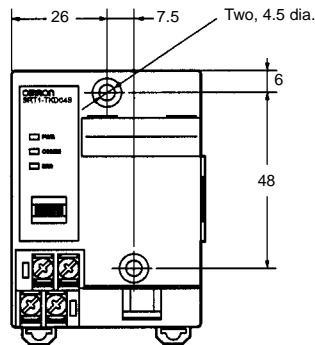
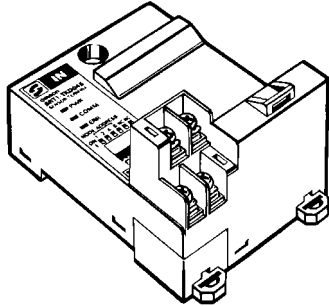

Mounting Holes

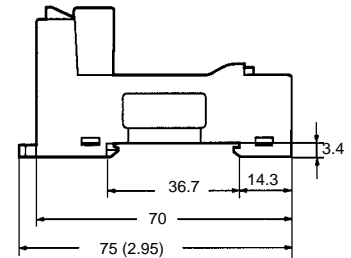
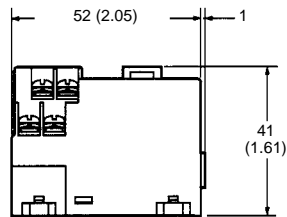
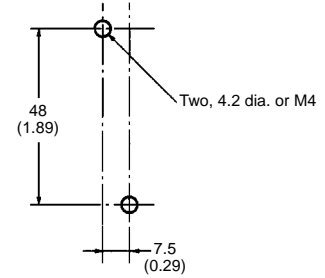

Unit: mm (inch)

SRT1-XKD04S

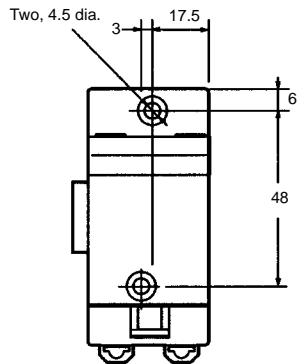
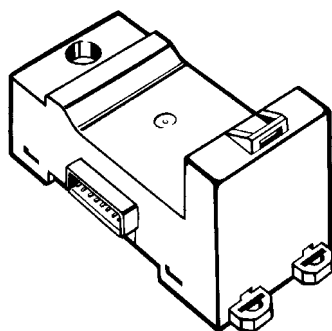

Mounting Holes

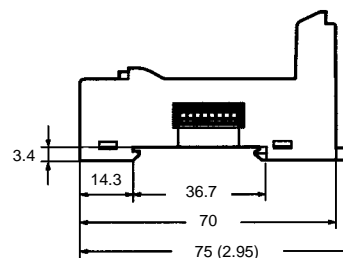
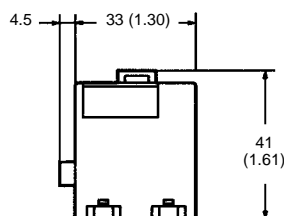
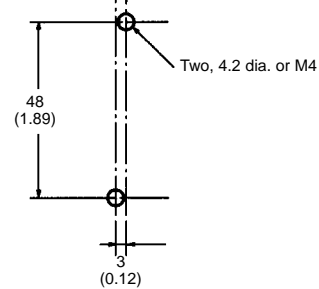

E3X-NM16

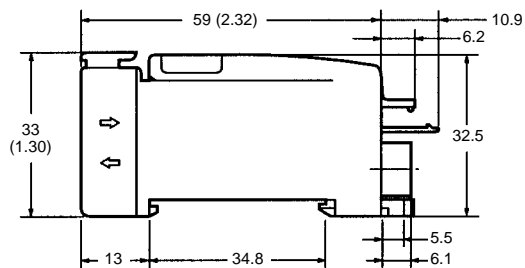
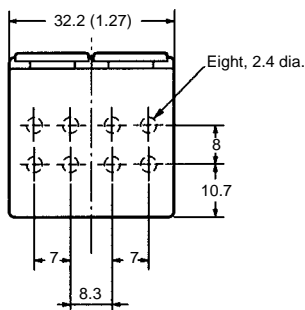
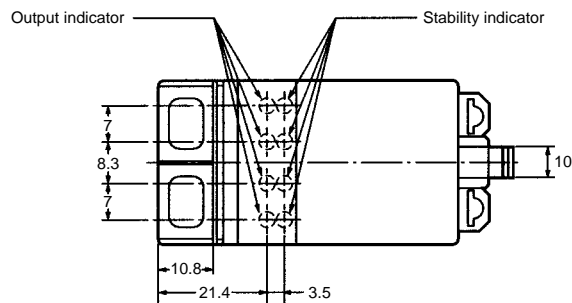
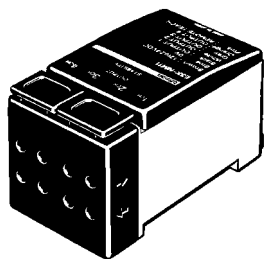

E3X-NH16

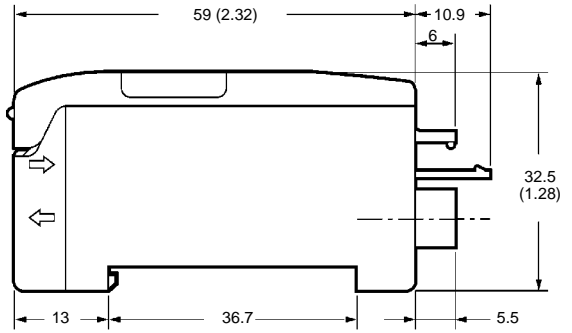
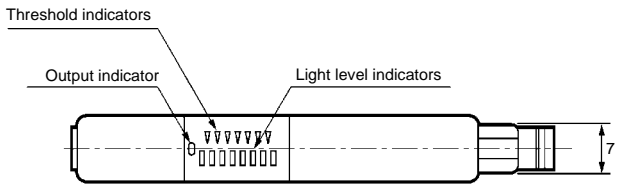
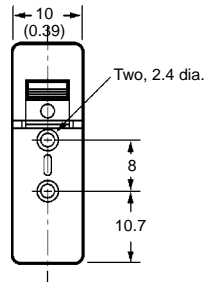
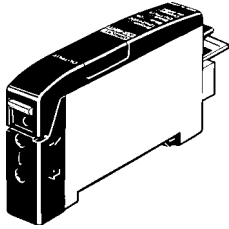

E3X-NT□6

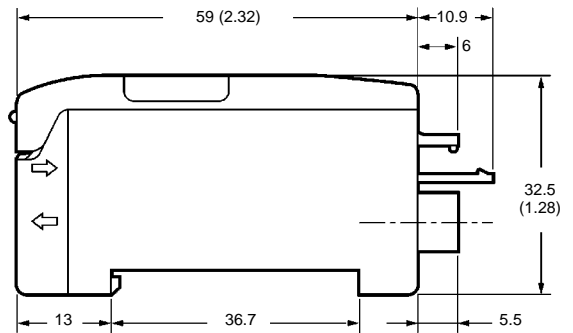
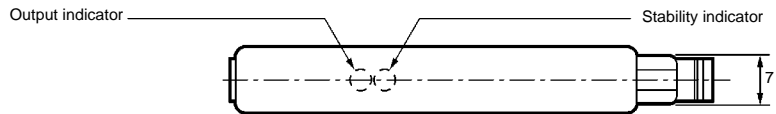
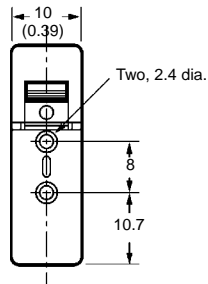
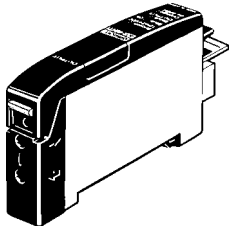

Unit: mm (inch)

E2C-T16

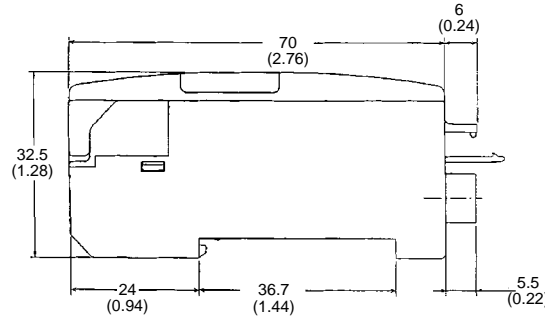
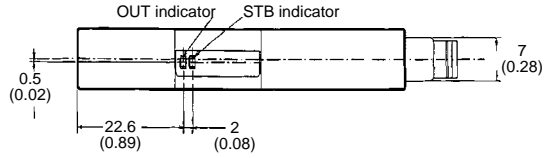
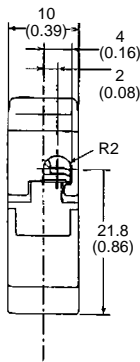
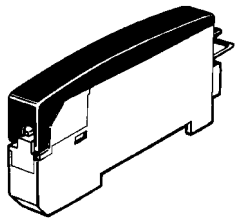

E39-JID01

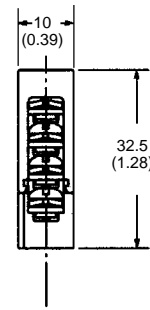
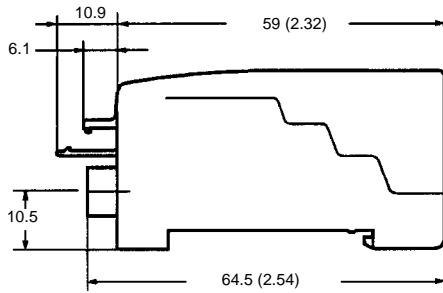
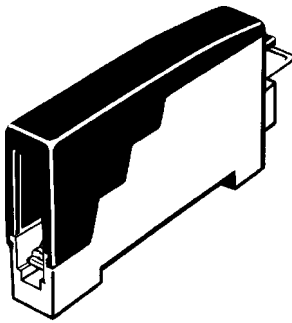
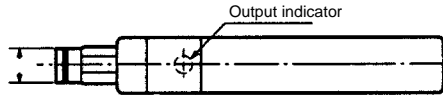

Installation

INTERNAL CIRCUIT CONFIGURATION

E39-JID01

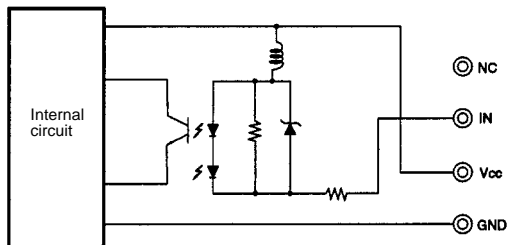

Precautions

Refer to the *CompoBus/S Operation Manual (W266)* before using the Terminal.

■ GENERAL SAFETY PRECAUTIONS

Sensor Amplifiers

Use only the Sensor Amplifier models listed in this data sheet with the CompoBus/S Terminals.

E39-JID01 Terminal Block

Do not apply any voltage to the Terminal Block Unit. Power for the sensor or switch wired to this terminal block is provided by the CompoBus/S Terminal.

■ CONNECTING EXPANSION TERMINAL TO COMMUNICATIONS TERMINAL

1. Remove the cover from the side of the Communications Terminal SRT1-T□D04S. (See Figure 1.)
2. When the cover is removed, you can see the receptacle for the expansion connector inside.
3. Insert the connector of Expansion Terminal into the Communications Terminal's receptacle. (See Figure 2.)

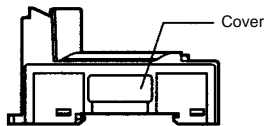

Figure 1

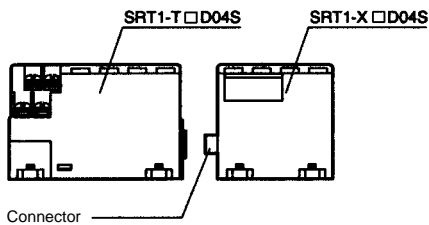

Figure 2

■ ATTACHING AND REMOVING SENSOR AMPLIFIERS

Attaching 1-Channel Amplifiers and Terminal Blocks

The following procedure shows how to install 1-channel Sensor Amplifiers or Terminal Block in CompoBus/S Communications and Expansion Terminals, models SRT□-TID04S and SRT□-XID04S.

1. Hook Section A of the Amplifier or Terminal Block onto Section B of the CompoBus/S Terminal.
2. Push in the Amplifier or Terminal Block until Section C locks inside Section D of the CompoBus/S Terminal.

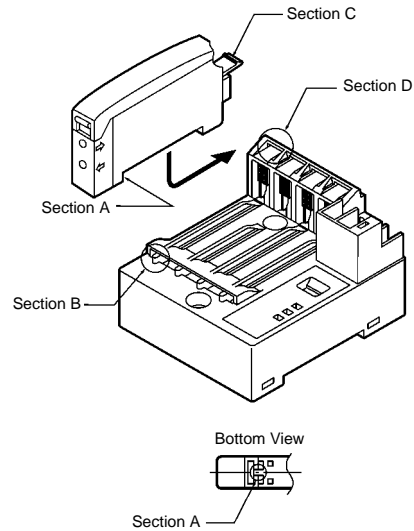

Removing 1-Channel Amplifiers and Terminal Blocks

1. While pushing Section D, pull the Amplifier or Terminal Block in direction E.
2. When Section D releases from the lock, the Amplifier or Terminal Block can be removed.

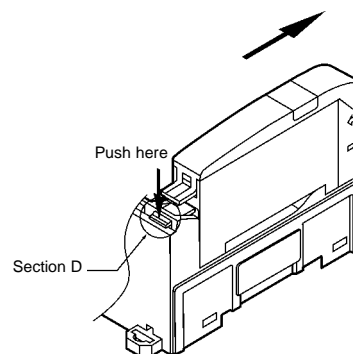

Attaching 4-Channel Amplifiers

The following procedure shows how to install 4-channel Sensor Amplifiers in CompoBus/S Communications and Expansion Terminals, models SRT□-TKD04S and SRT□-XKD04S.

1. Hook Section A of the Amplifier onto Section B of the CompoBus/S Terminal.
2. Push in the Amplifier until Section C locks inside Section D of the CompoBus/S terminal.

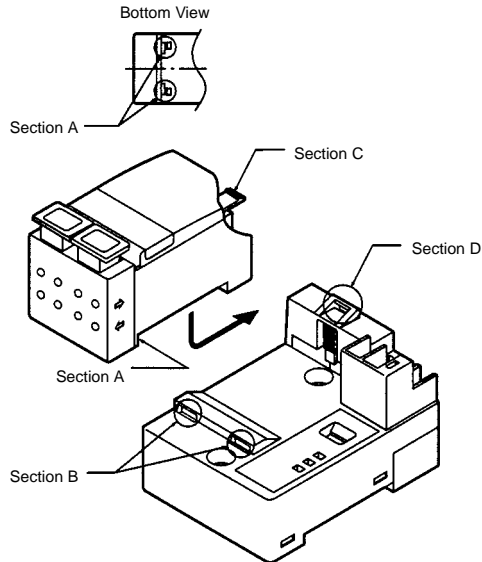

Removing 4-Channel Amplifiers

1. While pushing Section D, pull the Amplifier in direction E.
2. When Section D releases from the lock, the Amplifier can be removed.

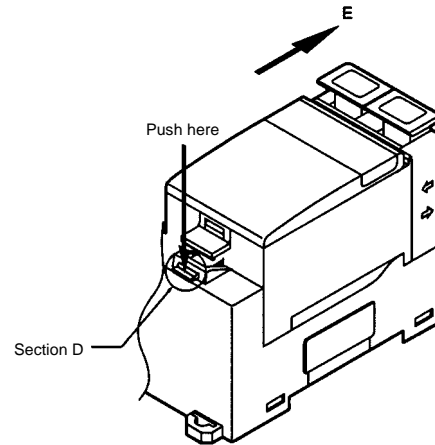

■ CHANNEL NUMBERS

1-channel Amplifiers and Terminal Block

Channel numbers for each Amplifier or Terminal Block correspond to contact numbers 0 to 3 of the SRT□-TID04S Communications Terminal, and to contact numbers 4 to 7 of the SRT□-XID04S Expansion Terminal.

4-channel Amplifiers

Channel numbers 1 to 4 of the E3X-NM16 Amplifier correspond to contact numbers 0 to 3 of the SRT□-TKD04S Communications Terminal, and to contact numbers 4 to 7 of the SRT□-XKD04S Expansion Terminal.

NOTE: DIMENSIONS SHOWN ARE IN MILLIMETERS. To convert millimeters to inches divide by 25.4.

OMRON®

OMRON ELECTRONICS, INC.

One East Commerce Drive
Schaumburg, IL 60173

1-800-55-OMRON

OMRON CANADA, INC.

885 Milner Avenue
Scarborough, Ontario M1B 5V8

416-286-6465