



**TELEDYNE RELAYS**  
A Teledyne Technologies Company



**SURFACE MOUNT,  
HIGH REPEATABILITY,  
BROADBAND  
TO-5 RELAYS  
DPDT**

**SERIES  
SRF300  
SRF303**

SERIES DESIGNATION	RELAY TYPE
SRF300	Repeatable, RF TO-5 relay
SRF303	Sensitive, repeatable, RF TO-5 relay

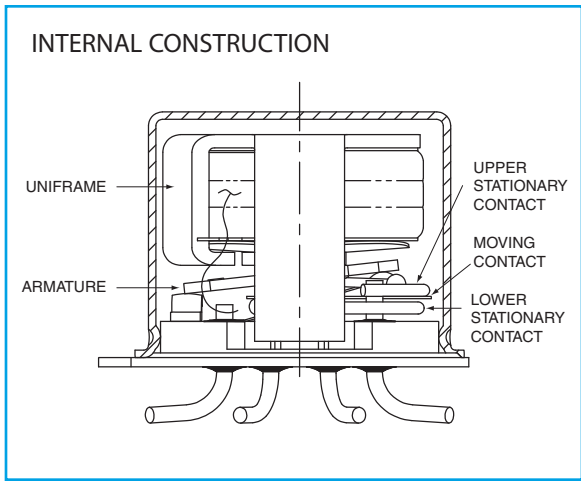

**DESCRIPTION**

The ultraminiature SRF300 and SRF303 relays are designed to provide a practical surface-mount solution with improved RF signal repeatability over the frequency range. These relays are engineered for use in RF attenuator, RF switch matrices, ATE and other applications that require dependable high frequency signal fidelity and performance.

The SRF300 and SRF303 feature:

- High repeatability
- Broader bandwidth
- Metal enclosure for EMI shielding
- High isolation between control and signal paths
- High resistance to ESD

The following unique construction features and manufacturing techniques provide excellent robustness to environmental extremes and overall high reliability:

- Uniframe motor design provides high magnetic efficiency and mechanical rigidity
- Minimum mass components and welded construction provide maximum resistance to shock and vibration
- Advanced cleaning techniques provide maximum assurance of internal cleanliness
- Hermetically sealed
- Solder Dipped Leads, (RoHS compliant solder option available)

**ENVIRONMENTAL AND PHYSICAL SPECIFICATIONS**

Temperature (Ambient)	Storage	-65°C to +125°C
	Operating	-55°C to +85°C
Vibration (General Note 1)		10 g's to 500 Hz
Shock (General Note 1)		30 g's, 6ms half sine
Enclosure		Hermetically sealed
Weight	SRF300	0.09 oz. (2.55g) max.
	SRF303	0.16 oz. (4.5g) max.

Teledyne Part Numbering System for SMT Relays

SRF300 - 5 / R



SERIES SRF300 AND SRF303  
TYPICAL RF CHARACTERISTICS (See RF Notes)

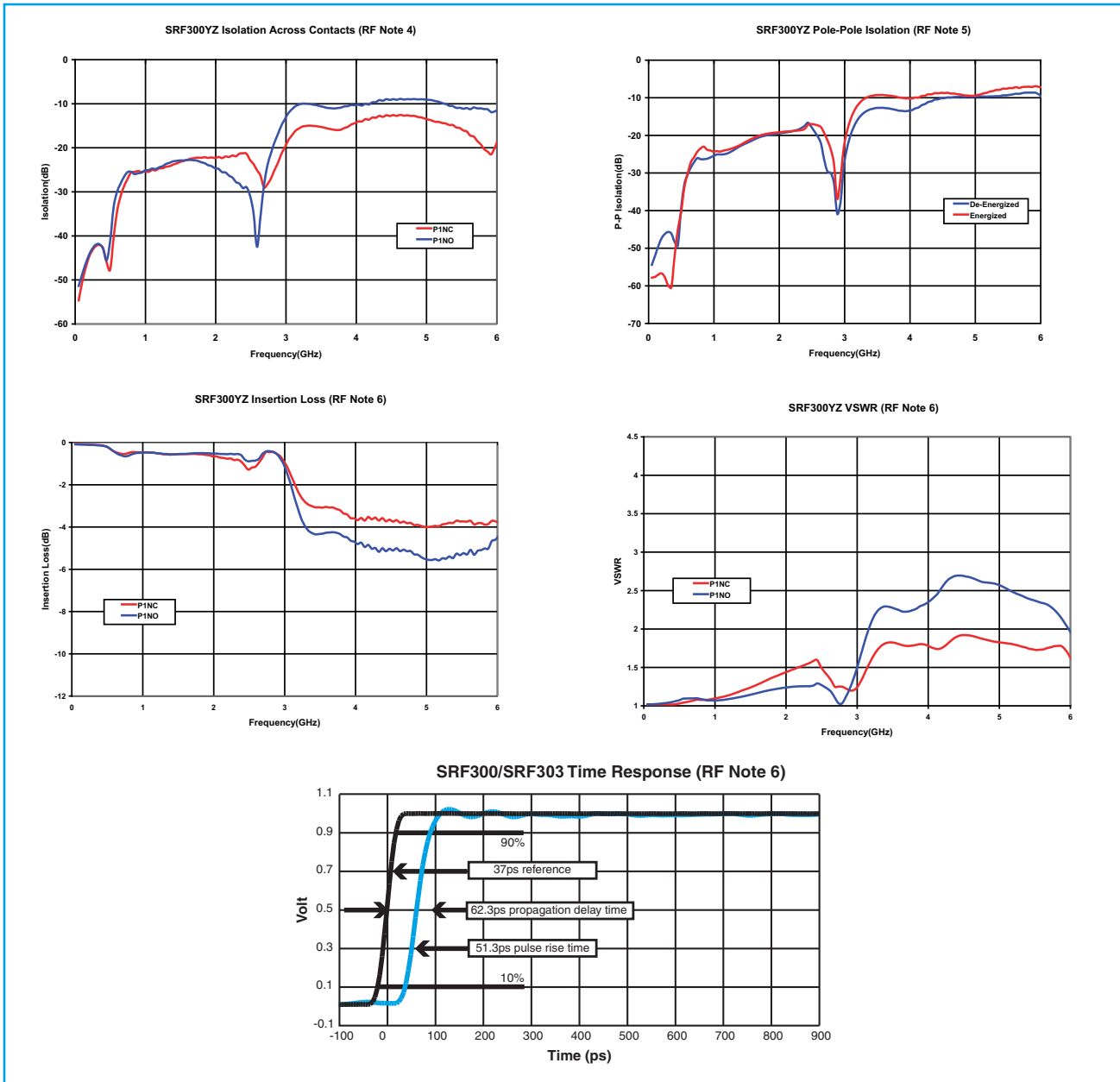

RF NOTES

1. Test conditions:
  - a. Fixture: .031" copper clad, reinforced PTFE, RT/duroid® 6002 with SMA connectors. (RT/duroid® is a registered trademark of Rogers Corporation.)
  - b. Room ambient temperature.
  - c. Terminals not tested were terminated with 50-ohm load.
  - d. Contact signal level: -10 dBm.
  - fe No. of test samples: 4.
2. Data presented herein represents typical characteristics and is not intended for use as specification limits.
3. Data is per pole, except for pole-to-pole data.
4. Data is the average from readings taken on all open contacts.
5. Data is the average from readings taken on poles with coil energized and de-energized.
6. Data is the average from readings taken on all closed contacts.
7. Test fixture effect de-embedded from frequency and time response data.

SERIES SRF300 AND SRF303  
 GENERAL ELECTRICAL SPECIFICATIONS (@25°C unless otherwise noted) (Notes 2 & 3)

Contact Arrangement	2 Form C (DPDT)
Rated Duty	Continuous
Contact Resistance	0.15 Ω max.
Contact Load Rating	Resistive: 1Amp/28Vdc Low level: 10 to 50 μA @ 10 to 50 mV
Contact Life Ratings	10,000,000 cycles (typical) at low level
Coil Operating Power	SRF300-5: 500 mW typical @ nominal rated voltage SRF300-12: 370 mW typical @ nominal rated voltage SRF303-5: 250 mW typical @ nominal rated voltage SRF303-12: 169 mW typical @ nominal rated voltage
Operate Time	SRF300: 4.0 mS max. SRF303: 6.0 mS max.
Release Time	SRF300: 3.0 mS max. SRF303: 3.0 mS max.
Intercontact Capacitance	0.4 pf typical
Insulation Resistance	1,000 MΩ min. between mutually isolated terminals
Dielectric Strength	350 Vrms (60 Hz) @ atmospheric pressure

DETAILED ELECTRICAL SPECIFICATIONS (@25°C)

BASE PART NUMBERS	SRF300-5/SRF303-5	SRF300-12/SRF303-12
Coil Voltage, Nominal (Vdc)	5.0	12.0
Coil Resistance (Ohms ±20%)	SRF300	50
	SRF303	100
Pick-up Voltage (Vdc max.)	3.6	9.0

GENERAL NOTES

- Relays will exhibit no contact chatter in excess of 10 μsec or transfer in excess of 1 μsec.
- Unless otherwise specified, parameters are initial values.
- Relays may be subjected to 260°C, peak solder reflow temperature, three 1 minute passes.
- Butt-lead ends are coplanar within .003" (0.08).
- Application notes available for PCB layout and mounting information.
- Terminals coated with SN60 or SN63 solder.
- Add "/R" to end of part number for RoHS compliant solder coated pins (Sn99.3/Cu0.7).

OUTLINE DIMENSIONS

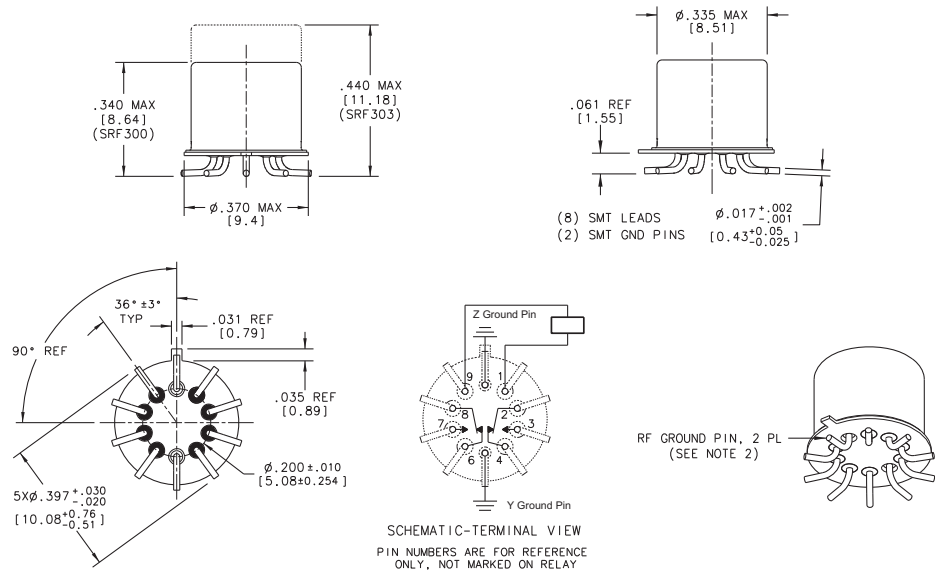

NOTES:

- DIMENSIONS ARE IN INCHES, METRIC EQUIVALENTS SHOWN IN [ ].
- FOR BEST RF PERFORMANCE, SOLDER ENDS OF RF GROUND PINS TO PCB RF GROUND PLANE.
- POSITIONS 5 AND 10 ARE FOR UNINSULATED CASE GROUND OPTIONS.
- DRAWING SHOWS: SRF300YZ