

Features

- Designed for Continuous Duty Operation
- Dust Proof Cover
- Requires Minimal PC Board Area
- Switches Heavy Current with Low Coil Power



R20 Series



General Purpose, 8 Amp DPDT DC Printed Circuit Mount Relay.

D14

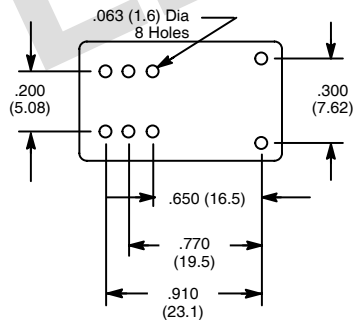
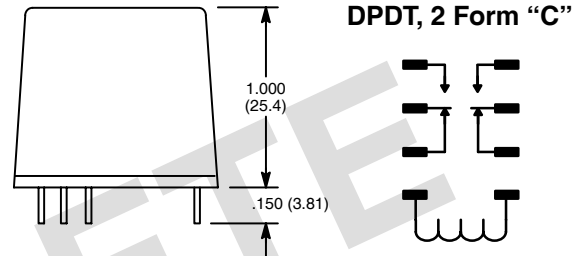

DC OPERATED						
NTE Type No.	Nom. Voltage	Contact Arr.	Coil Res. Ohms (Typ)	Nom. Power	Max. Contact Cur. @ 28VDC or 120VAC	Diag No.
R20-11D6-6	4.5/5VDC	DPDT	25	800mW	8A	D14
R20-11D6-12	12VDC	DPDT	170	800mW	8A	D14
R20-11D6-24	24VDC	DPDT	1098	800mW	8A	D14

Electrical Specifications

Contact

Rating: 8 Amp @ 120/250 VAC, 8 Amp 30 VDC
1/6 HP @ 120 VAC

Contact Material: Silver cadmium oxide, gold flashed
Contact Resistance: 0.05 Ohms Max. initial

Coil

Coil Voltages: See Chart

Pick-up Voltage: 80% of nominal or less @ 25°C

Drop-out Voltage: 10% of actual pull-in (min)

Resistance: See chart

Operational Characteristics

Timing Value Operate Time: Approx 10 mS

Release Time: Approx 8 mS

Max Switching Rate: 5 operations per second

Insulation Characteristics

Dielectric Strength

Contact To Coil: 1500 VRMS

Contact To Frame: 1500 VRMS

Across Open Contacts: 500 VRMS

Coil To Frame: 1000 VRMS

Insulation Resistance: 1000 megohms Min. @ 500 VDC

Environmental Characteristics

Operating: -45°C to +75°C

Mechanical Life: 5,000,000 operations min

Weight

Std: 14.2 gram approx.