



**Applied
Motion
Products**

BLuAC5 Brushless Universal Servo Amplifier

Description

The BLu Series servo drives provide compact, reliable solutions for a wide range of motion applications in a variety of industries. BLu Series drives are designed to offer excellent performance coupled with hardware and software features that make them easy to integrate, use and maintain.

The BLuAC5 hardware features a powerful digital signal processor (DSP) coupled to an efficient IGBT PWM amplifier. When combined with the BLuAC5's sophisticated, yet easy to tune position loop and velocity and acceleration feed-forward, a system capable of extremely high performance results assuring success in even the most demanding of applications.

All BLuAC5 drives are capable of running brushless, brush and linear type motors. A timing wizard automatically configures the encoder and commutation timing for virtually any brushed or brushless DC motor. Tuning is easy with our QuickTuner™ software, which features a built-in digital oscilloscope.

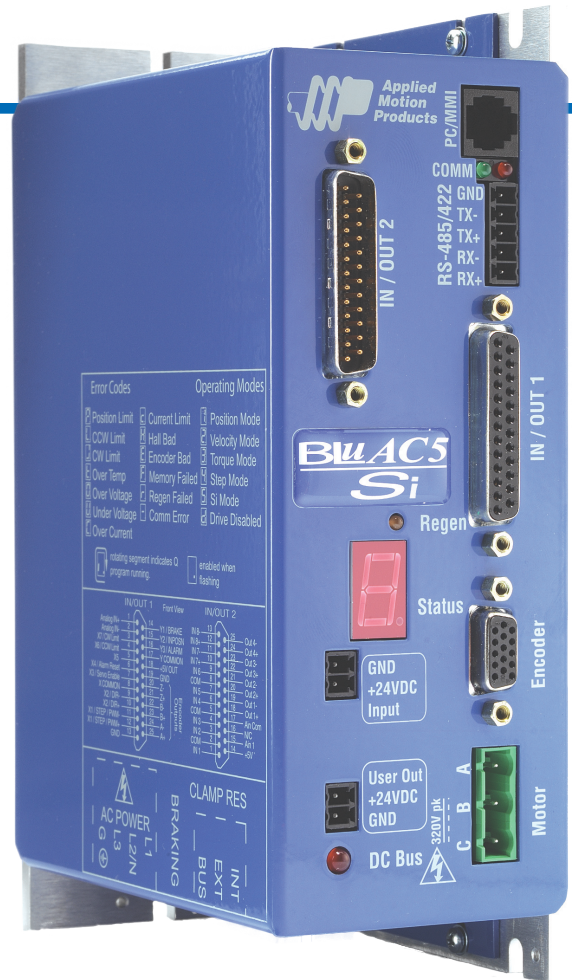

- ▶ **5A Continuous/15A Peak**
- ▶ **950W Max**
- ▶ **90-260VAC Input, Single or Three Phase**
- ▶ **QuickTuner™ configuration software**
- ▶ **Status Display**
- ▶ **External control options -**
 - **Pulse and Direction**
 - **Analog Command Signal**
 - **Host command via RS232/485.**
- ▶ **Integral control options -**
 - **Si Programmer™ - intuitive easy to use graphical programming language.**
 - **Q - comprehensive high level language with options for control of all drive features.**

BLuAC5 Features

- Drives Brushless sinusoidal, Brushless trapezoidal, Brush or Linear type motors
- 2 to 24 Pole Brushless motor compatibility
- Speeds to 8000 rpm (Motor and load dependent).
- 16 kHz precision PWM amplifier.
- 24V Isolated I/O power supply output
- 24V Auxilliary logic supply input (“keep alive” input)
- Internal “Regeneration clamp” circuit and power resistor

Drive Models



BLuAC5-S

Basic drive; Analog, digital and host command input.

- pulse & direction with electronic gearing
- encoder following with electronic gearing
- analog +/-10V. Torque , Velocity and Positioning.
- CW and CCW pulse
- multi-axis Si programming if used with a SiNet Hub
- “Host” commands for real time control from a host PC or PLC using RS-232 or RS-485 serial communication.

BLuAC5-Si

BLuAC5-Si can be programmed for stand-alone operation with the easy to use Si Programmer™ Windows software with integrated tuning (software and programming cable included).

Graphical point and click format combines motion, I/O, and operator interface functionality for simple machine sequencing.

Easily integrates with other devices on the machine (Sensors, PLCs etc).

BLuAC5-Q

Q programming. Comprehensive programming language with options for downloading, storing and executing multiple programs.

- Q Programming environment
 - Register manipulation
 - Conditional processing
 - Math functions
 - Multi-tasking
- pulse & direction with electronic gearing
- encoder following with electronic gearing
- analog +/-10V. Torque , Velocity and Positioning.
- CW and CCW pulse

Features Summary

		BLuAC5-S	BLuAC5-SE	BLuAC5-Q	BLuAC5-QE	BLuAC5-Si
Hub		✓	✓			✓
Command Inputs	Analog +/-10V	✓	✓			
	Pulse and Direction	✓	✓			
	CW and CCW Pulse	✓	✓			
	Master Encoder	✓	✓			
Command Modes	Host Command Language	✓	✓	✓	✓	✓
	Si Indexer					✓
	Q Programming			✓	✓	
Logic Input Functions	Alarm Reset	✓	✓	✓	✓	
	Limit Switches	✓	✓			
	Servo Enable	✓	✓	✓	✓	✓
Logic Output Functions	Alarm	✓	✓	✓	✓	✓
	Brake	✓	✓	✓	✓	✓
	In Position	✓	✓	✓	✓	✓
Digital Inputs		7	15	7	15	15
Digital Outputs		3	7	3	7	7

BLuAC5 Servo Drive

Features

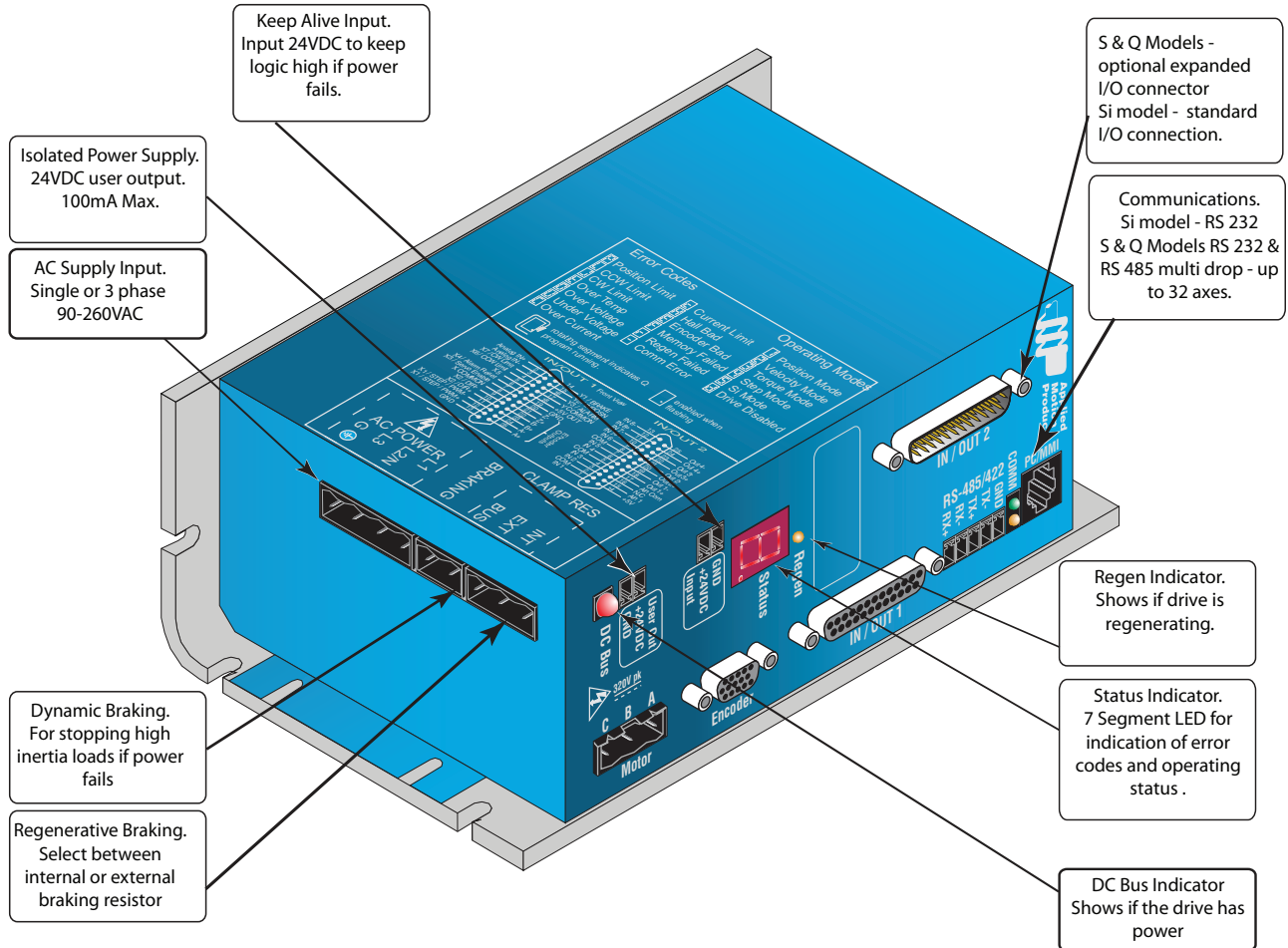

Status Display Codes

Error Codes

- Position Limit
- CCW Limit
- CW Limit
- Over Temp
- Over Voltage
- Under Voltage
- Over Current/Short

- Current Limit
- Hall Bad
- Encoder Bad
- Memory Error
- Regen Failed
- Comm Error

Operating Modes

- Position Mode
- Velocity Mode
- Torque Mode
- Step Mode
- Si Mode
- Drive Disabled

enabled when flashing

rotating segment indicates Q program running.

QuickTunerSetup Software

The BLuAC5 servo drives are supplied with the *QuickTuner™* software set-up utility. In this one program the user can configure all the aspects of the drive. This includes setting the current, configuring Inputs and Outputs and tuning the drive using the integrated oscilloscope with new trigger function.

The drive screen allows the user to enter parameters for the drive and select the operating mode required.

The Inputs/Outputs screen is used to configure the functionality of the drive. These functions may include.

- Brake output
- Alarm Output
- Motion Output
- Limit Switch inputs

The oscilloscope function can be used to display the effects of varying the different gain parameters. A number of different drive parameters can be displayed including:

- Target Speed
- Actual Speed
- Current
- Position Error
- Supply Voltage

The oscilloscope function also features a trigger function and a monitor, this displays parameter values in real time.

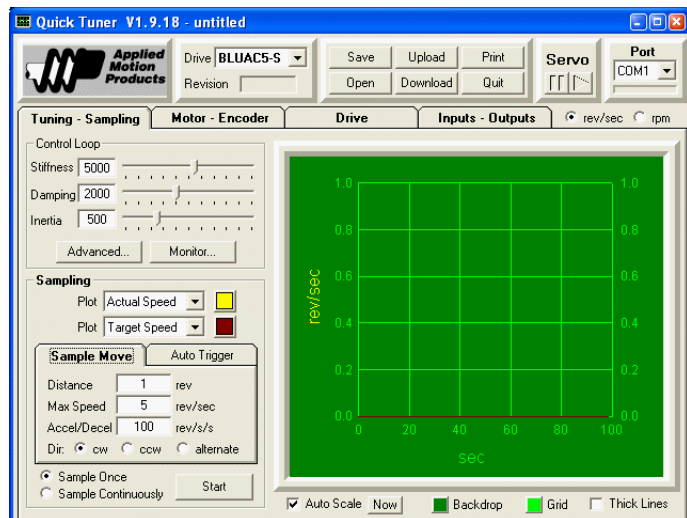
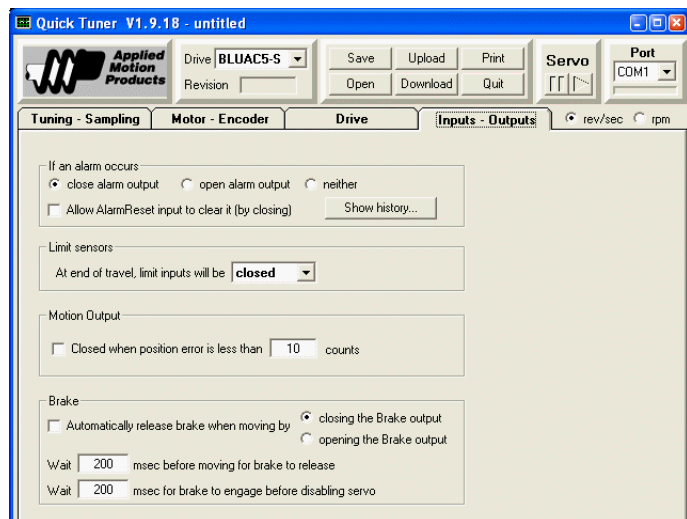
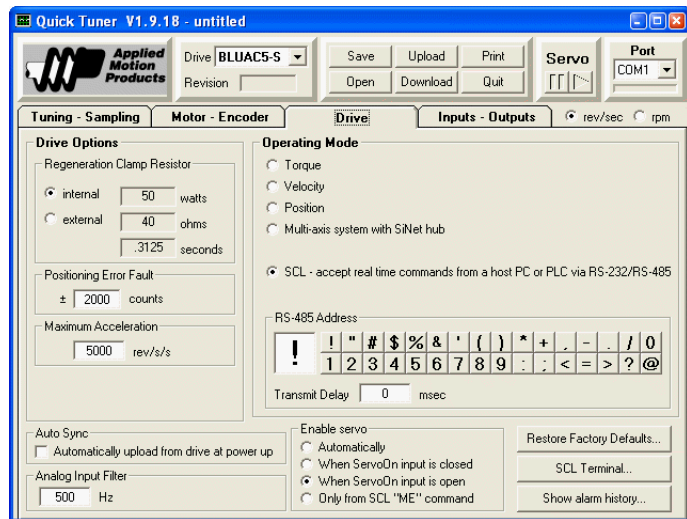

BLuAC5 Technical Specifications

POWER AMPLIFIER:

AMPLIFIER TYPE	3 phase Sinusoidal PWM switching at 16 KHz.
CURRENT CONTROL.....	4 quadrant "DQ" method
OUTPUT CURRENT	5 amps continuous. 15 amps peak current, one second max rms.
AC INPUT VOLTAGE	90 - 260VAC 50/60Hz, 1 phase or 3 phase
BUILT IN REGENERATION.....	50 Watt internal shunt resistor. Connector for high power external shunt resistor.
PROTECTION	Over-current/short circuit Over temperature (75°C) Over voltage (400VDC on DC Bus) Under voltage (100VDC on DC Bus) Regeneration Error (Based on Regeneration values) Encoder Failure (When using differential input) Hall sensor Failure
POSITION FEEDBACK	Incremental Encoder, A/B Quadrature (50 to 32,000 line), up to 2MHz.
POSITION RESOLUTION	Set via software to match encoder resolutions from a minimum of 50 lines to a maximum of 32,000 lines per revolution producing a minimum of 200 counts to a maximum of 128,000 counts per revolution in quadrature.
Max Speed	Speeds to 8000 rpm. Motor and load dependent.

CONTROLLER SECTION:

MOTION UPDATE.....	16 kHz.
SERVO UPDATE	4 kHz.
SERIAL COMMUNICATION	RS-232 or RS-422/RS-485 programming & control port (RS-485 S & Q versions only). Green and Amber LED's for Receive and Transmit indication. Each drive is addressable for multi-axis control (S & Q versions only). Selectable Baud rates of 9600, 19200, 38400, 57600, 115200.
STATUS INDICATOR.....	7-Segment LED for Status, Operation and Error code display
DIGITAL INPUTS AND OUTPUTS	All Optically Isolated, 2 high speed inputs for Encoder Following or Step & Direction input.
ANALOG INPUT.....	Configurable as single-ended or differential $\pm 10V$, $\pm 5V$, 0-5V or 0-10V. This can be read as one differential or two single ended inputs, dependant on product model. Si;Not Supported , S model; one input Single or Differential, Q; One Single or Differential or two Single Ended.
S & Q PARAMETER RANGES.....	Distance: 1 to 2,147,483,647 (CW or CCW), relative or absolute position in encoder counts. Speed: .0042 to 133 revolutions per second. Acceleration: 0.167 to 5,000 rev/sec/sec. Deceleration: 0.167 to 5,000 rev/sec/sec (set independently from acceleration). Time Delays: .01 to 320 seconds.
Si PARAMETER RANGES	Distance: 1 to 16,000,000 (CW or CCW), absolute position ± 2 billion. Speed: .025 to 100 revolutions per second. Acceleration: 1 to 3,000 rev/sec/sec. Deceleration: 1 to 3,000 rev/sec/sec (set independently from ac-

BLuAC5 Servo Drive

celeration).
 Time Delays: .01 to 300 seconds.
 Output Pulse Widths: 2 to 500 milliseconds.
 Iterations per loop: 1 to 65,535.
 Nested loops :50
 Subroutine calls: 5 deep max

SYSTEM SPECIFICATIONS:

WEIGHT 2 lb. 12 oz.
 AMBIENT TEMPERATURE..... 0 to 40 deg C (32 to 104 deg F).
 HUMIDITY..... Maximum of 90% non-condensing.
 CONNECTORS..... Screw terminal connectors for input power, and motor, HD-15 for encoder/Hall signals. DB25 for signal and I/O. Si has DB25P for User I/O.
 RECOMMENDED MOTORS Can drive AMP BLDC Motors to 950W at full speed.

Model	Total I/O	Dedicated Inputs # Note 1		General Purpose Inputs	Dedicated Outputs #		General Purpose Outputs
		Qty	Function		Qty	Function	
BLuAC5-S	7/ 3	6	Limit Switches (2) Alarm Reset Servo Enable Jog CW & CCW	1	3	Alarm Brake Motion	0
BLuAC5-Q	7/ 3	6	Limit Switches (2) Alarm Reset Servo Enable Jog CW & CCW	1	3	Alarm Brake Motion	0
BLuAC5-Si	15/ 7	4	Limit Switches (2) Jog CW & CCW	11	3	Alarm Brake Motion	4

Note 1: Dedicated I/O points can be used as General purpose when dedicated function is not needed.

Note 2: I/O Expansion providing 8 additional Inputs and 4 additional outputs can be added to both "S" and "Q" versions.

Note 3: Encoder index (Z channel) can be used as an additional input for homing if present.

BLuAC5 Servo Drive

BLuAC5 Outline Drawings

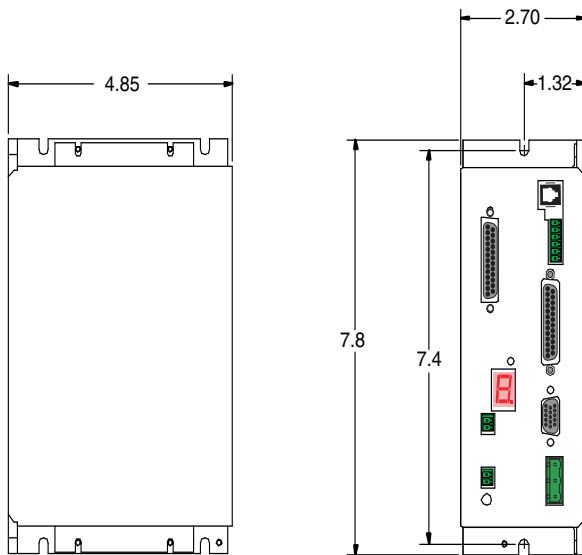

BLuAC5 Connections

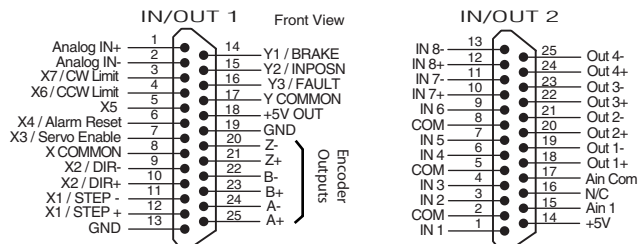

Note - this connector is standard on Si version and only on S and Q versions with expanded I/O.

Recommended Motors for use with BLuAC5 Servo Drive Alpha N & M Series

		60 mm & NEMA 23	80 mm & NEMA 34		
Motor Model AMP		M0400-101-4-000 N0400-101-B-000	M0400-102-5-000 N0400-102-C-000	M0600-102-5-000 N0600-102-C-000	M0750-102-5-000 N0750-102-C-000
Power Supply	V	100	200	200	200
Rated Output (PR)	W	400	400	600	750
Rated Torque (TR)	N.m	1.27	1.27	1.91	2.39
	lb.in	11.24	11.24	17	21
Peak Torque (TP)	N.m	3.82	3.82	5.73	7.16
	lb.in	33.8	33.8	50	64
Rated Speed	r/min	3000	3000		
Maximum Speed	r/min	5000	5000		
Rated Armature Current of E.D.C.M	A rms	5.6	2.8	4.4	5.0
Peak Armature Current of E.D.C.M	A rms	16.3	8.0	12.9	14.5
Torque Constant of E.D.C.M	N.m/A ^{+/-10%}	0.24	0.49	0.45	0.5
	lb.in/A	2.12	4.3	4	4.4
Voltage Constant of E.D.C.M	V/(r/min) ^{+/-10%}	24.8 x 10 ⁻³	50.8 x 10 ⁻³	42 x 10 ⁻³	52.2 x 10 ⁻³
Rotor Moment of Inertia	g-cm ²	340	560	980	1080
	oz-in-sec ²	4.7 x 10 ⁻³	7.9x10 ⁻³	13.8x10 ⁻³	15.2x10 ⁻³

N & M Series Motors can be supplied with optional holding brake - refer to Servo Motors Databook or Website for details

BLuAC5 Servo Drive

Alpha M Series 60mm Motor

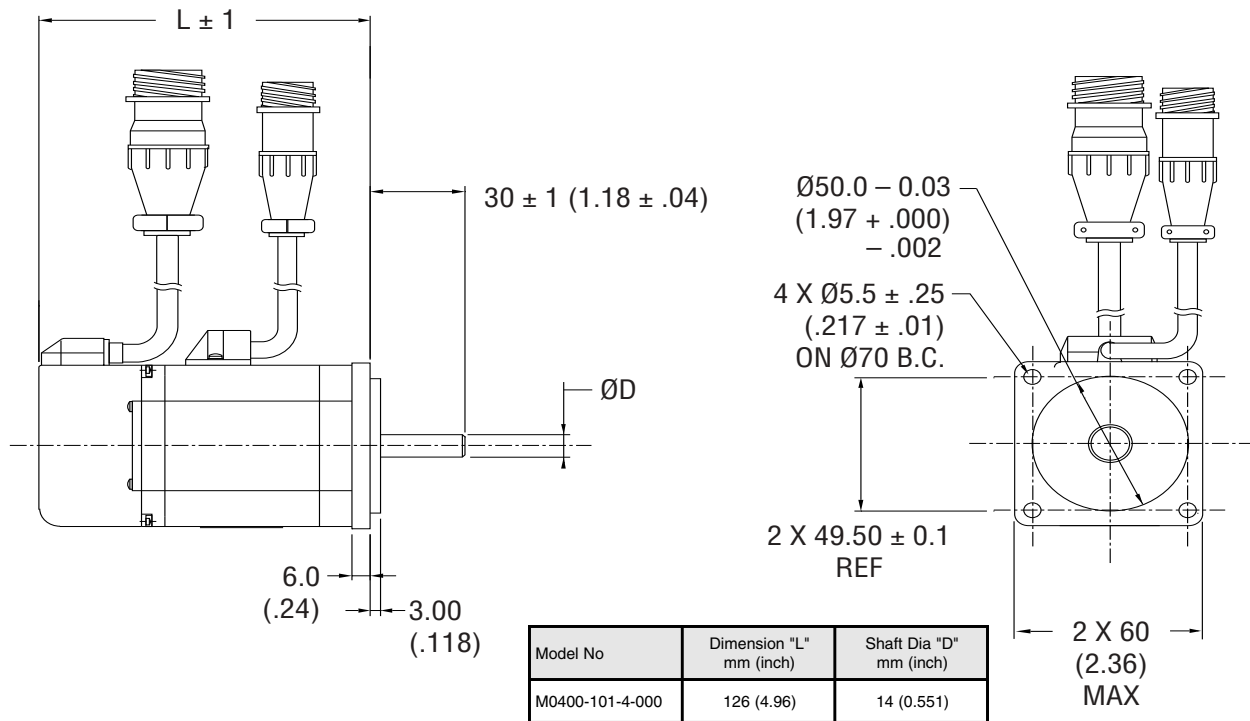

Alpha M Series 80mm Motor

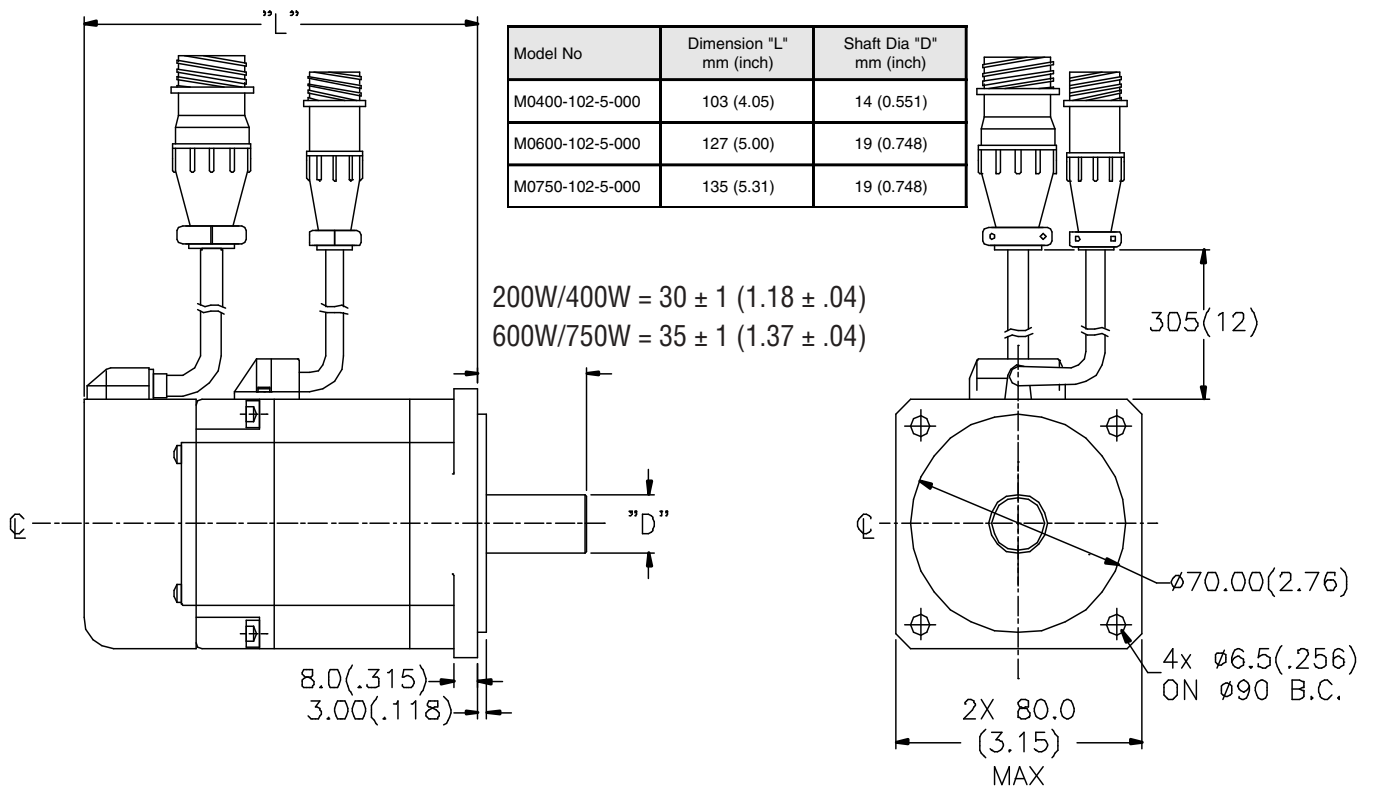

N Series NEMA 23 Motor

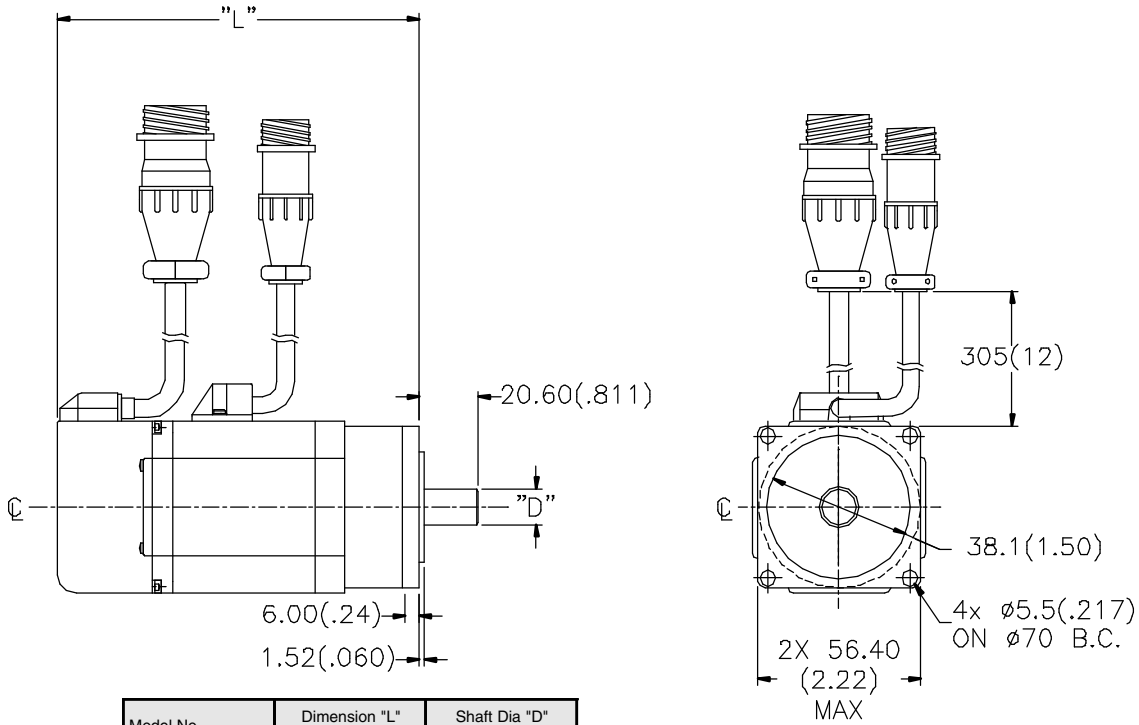

Model No	Dimension "L" mm (inch)	Shaft Dia "D" mm (inch)
N0400-101-B-000	149 (5.86)	12.7 (0.5)

N Series NEMA 34 Motor

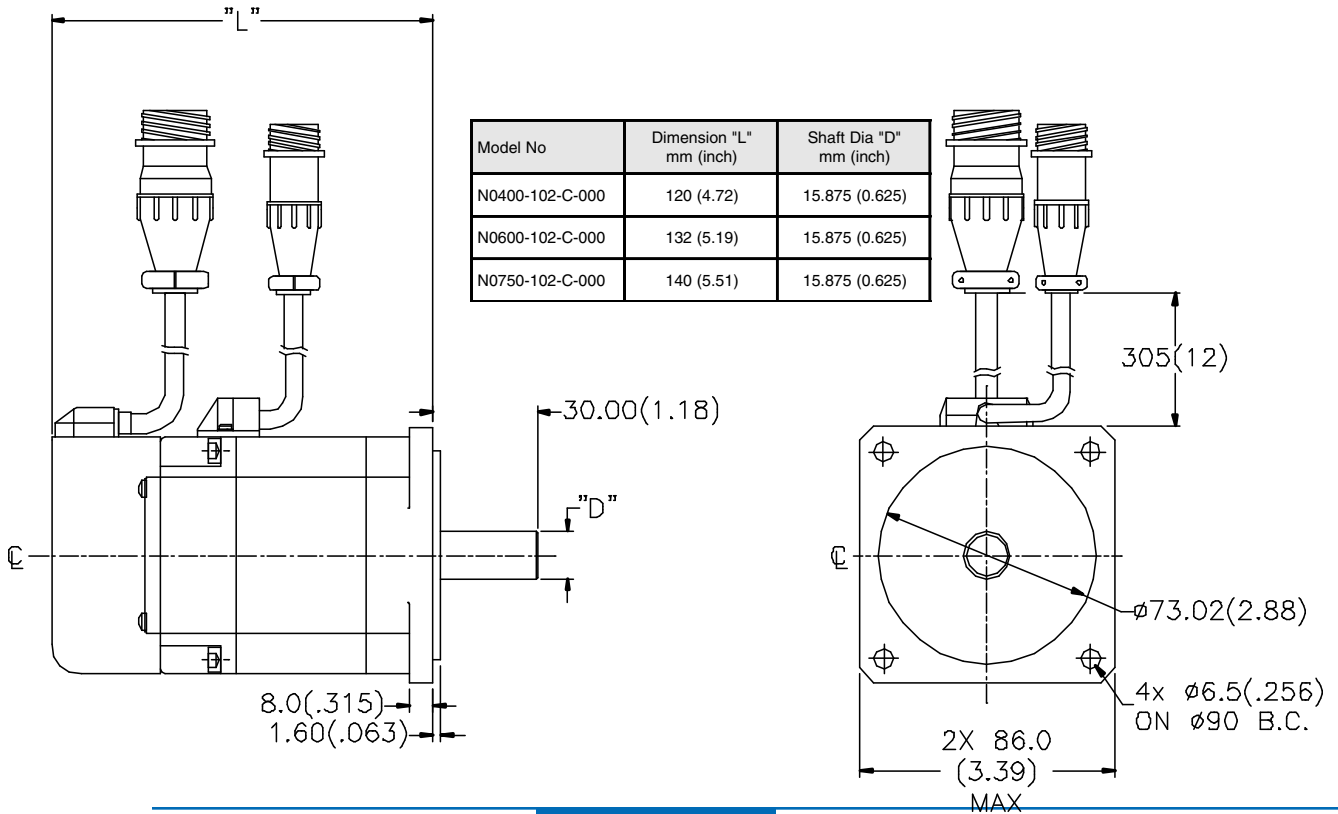

Model No	Dimension "L" mm (inch)	Shaft Dia "D" mm (inch)
N0400-102-C-000	120 (4.72)	15.875 (0.625)
N0600-102-C-000	132 (5.19)	15.875 (0.625)
N0750-102-C-000	140 (5.51)	15.875 (0.625)

BLuAC5 Torque Curves for Recommended Motors

A00400-101-4-000, Alpha Motor

BLuAC5 set at 5.0 amps (15.0 peak)
100 VAC Supply

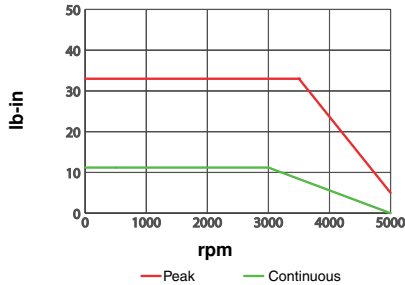

A0600-102-5-000, Alpha Motor

BLuAC5 set at 4.2 amps (12.6 peak)
200 VAC Supply

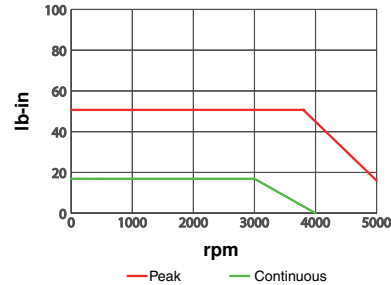

A0800-102-5-000, Alpha Motor

BLuAC5 set at 4.6 amps (13.8 peak)
200 VAC Supply

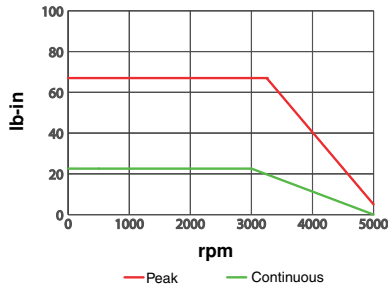

A0950-102-5-000, Alpha Motor

BLuAC5 set at 4.4 amps (13.2 peak)
200 VAC Supply

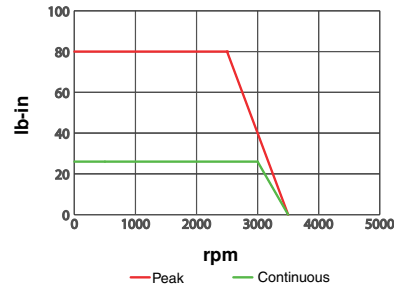

M0400-101-4-000, M Series Motor

N0400-101-B-000, M Series Motor

BLuAC5 set at 5.0 amps (15.0 peak)
100 VAC Supply

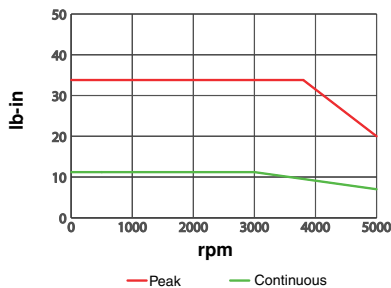

M0400-102-5-000 M Series Motor

N0400-102-C-000 N Series Motor

BLuAC5 set at 2.7 amps (7.8 peak)
200 VAC Supply

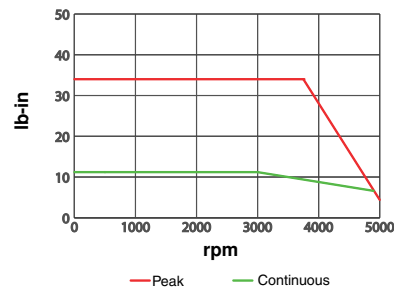

M0600-102-5-000 M Series Motor

N0600-102-C-000 N Series Motor

BLuAC5 set at 4.5 amps (12.8 peak)
200 VAC Supply

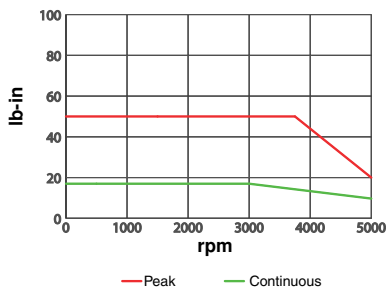

M0750-102-5-000 M Series Motor

N0750-102-C-000 N Series Motor

BLuAC5 set at 4.9 amps (14.1 peak)
200 VDC Supply

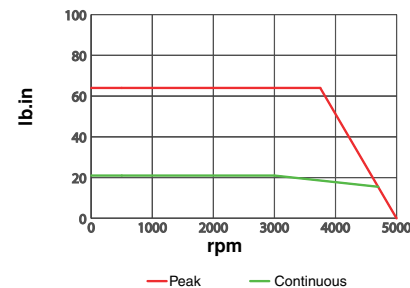

BLu AC5 Options

- I/O expansion kit (Part No BLuAC-EXTIO) increases the inputs to 15 and outputs to 7 on the BLuAC5-S and BLuAC5-Q models.
- Multi axis systems can be created using the Hub 444 or Hub8 multi port hubs and the SiNet™ Hub Programmer Software.
- External braking resistor module.
- Man Machine Interface (MMI 01 & MMI 02). Can be used with Si model only to enter variables.
- Break Out Board . A DIN rail mounted module that converts the 25 way DIN connectors to screw terminals.

Braking resistor assembly - RA-100

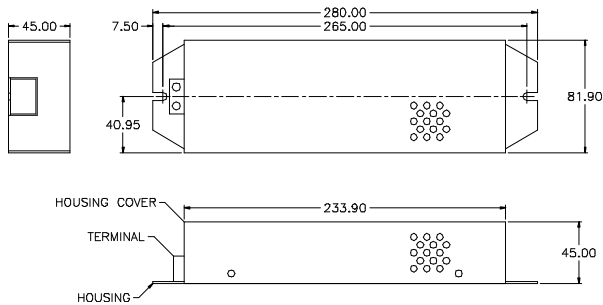

Break Out Board (BOB1 & BOB2)

- BOB1 is for use with all Drives and expands the IN OUT 1 connector to screw terminals.
- BOB2 is for use with Si version drives and S and Q models that are fitted with the expansion I/O. (supplied with 3' cable)

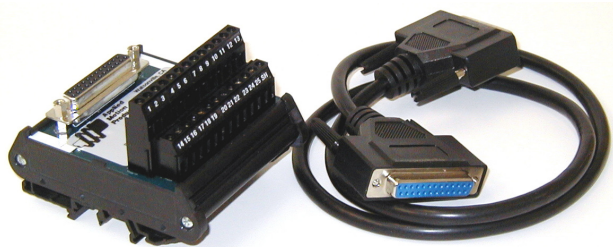

Distributed by:

Applied Motion Products
404 Westridge Dr. Watsonville, CA 95076
Tel: 831-761-6555 Fax: 831-761 -6544
www.applied-motion.com

Version 11/19/04